

SCHEDULE-AMENITY MILLWORK FINISH							
KEY NAME	DESCRIPTION	MANUFACTURER	STYLE/MODEL #	COLOR/FINISH	LOCATION	COMMENTS	MATERIAL COST
CAB-1	SHAKER STYLE FULL OVERLAY CABINET	ARAUCO LAMINATE / FABRICATOR PER GC	PRISM / SF208 FOLKSTONE / SHAKER STYLE	FOLKSTONE / SUEDE	LEASING LOBBY RECEPTION DESK / MODEL UNIT (UPPER CAB) / FITNESS / WORK ROOM		\$1.50 - \$1.80 / SF
CAB-2	SHAKER STYLE FULL OVERLAY CABINET	ARAUCO LAMINATE / FABRICATOR PER GC	PRISM / SF209 STORM / SHAKER STYLE	STORM / SUEDE	MAIL COFFEE BAR / MODEL UNIT (BASE CAB)		\$1.50 - \$1.80 / SF
CAB-3	SHAKER STYLE FULL OVERLAY CABINET	PER GC	CUSTOM PAINTED MELAMINE CABINET / SHAKER STYLE	PAINTED PT-5 (SEE WALL FINISH SCHEDULE)	KITCHEN	SUBMIT PAINTED CABINET SAMPLE FOR DESIGNER APPROVAL	
CAB-4	NOT USED (TO BE REFILE)	NOT USED	NOT USED	NOT USED			
CAB-5	CUSTOM BENCH AND BACK	PER GC	SEE ELEVATIONS AND SECTIONS FOR DESIGN INTENT	FINISHED WITH WD-9 (SEE WALL FINISH SCHEDULE)	KITCHEN		
CAB-6	CUSTOM BENCH AND BACK	PER GC	PAINT GRADE WOOD / SEE ELEVATIONS FOR DESIGN INTENT	PAINTED PT-7 (SEE WALL FINISH SCHEDULE)	CLUBROOM		
CAB-7	CUSTOM BENCH AND BACK	PER GC	STAIN GRADE WOOD / SEE ELEVATIONS FOR DESIGN INTENT	STAINED WS-1	GAME ROOM		
CAB-8	NOT USED	NOT USED	NOT USED	NOT USED			
CAB-9	FITNESS WALL CUBBIES	PER GC	STAIN GRADE WHITE OAK / SEE ELEVATIONS FOR DIMENSIONS AND DESIGN INTENT	STAINED WS-1	FITNESS		
F-1	FABRIC	UNITED FABRICS	LUSH	66 PATNA	MAILROOM BENCH CUSHIONS	FF&E COST - SUPPLIED THROUGH CDG	UPHOLSTERED CUSHIONS IN FF&E / \$56.95 PER YD
F-2	FABRIC	UNITED FABRICS	LEO	32 FEATHER	KITCHEN BANQUETTE CUSHIONS	FF&E COST - SUPPLIED THROUGH CDG	UPHOLSTERED CUSHIONS IN FF&E / \$27.45 PER YD
F-3	FABRIC	UNITED FABRICS	SORELLO	65 NORI	GAME ROOM BANQUETTE CUSHIONS	FF&E COST - SUPPLIED THROUGH CDG	UPHOLSTERED CUSHIONS IN FF&E / \$34.45 PER YD

SCHEDULE-AMENITY MILLWORK FINISH							
KEY NAME	DESCRIPTION	MANUFACTURER	STYLE/MODEL #	COLOR/FINISH	LOCATION	COMMENTS	MATERIAL COST
MIL-4	METALWOOD SUSPENDED SHELVING UNIT	LAMON LUTHER	2" STEEL TUBE FRAME / SOLID ASH OPEN SHELVES / OUTERMOST PANELS (TOP AND SIDES) WRAPPED W/ STEEL PLATING	STEEL: GUNMETAL GRAY / SHELVES: SOLID ASH WOOD STAINED TO MATCH WS-1	KITCHEN	PROJECT REFERENCE WITH MANUFACTURER: CHATTANOOGA SUSPENDED SHELVING	SHELVING UNIT (INCLUDES METAL PLATES): \$1,150.00 DELIVERY AND INSTALL ON-SITE: \$2,350.00
LAM-2	PLASTIC LAMINATE	WILSONART	PREMIUM LAMINATE / 8208K-16	FAWN CYPRESS / CASUAL RUSTIC FINISH	FITNESS AMENITY RESTROOM VANITIES		\$2.00 / SF
LAM-3	PLASTIC LAMINATE	WILSONART	PREMIUM LAMINATE / 7999K-12	FIELD ELM / SOFTGRAIN FINISH	CLUBHOUSE AMENITY RESTROOM VANITIES		\$2.00 / SF
SS-1	SOLID SURFACE	QUARTZ	CABARSTONE	4011 / 3 CM	CLUBHOUSE RECEPTION DESK / FITNESS AMENITY RESTROOMS	LEASING LOBBY RECEPTION DESK / FITNESS AMENITY RESTROOMS	\$29.95 / SF
SS-2	SOLID SURFACE	DEKTON	COSENTINO	INDUSTRIAL COLLECTION / 3CM	MAIL COFFEE BAR		\$28.00 / SF
SS-3	SOLID SURFACE	QUARTZ	MSI	PREMIUM PLUS / 3 CM	KITCHEN / CLUBHOUSE AMENITY RESTROOMS / FITNESS / PET SPA	MITER CORNERS OF EDGES AT CLUBHOUSE AMENITY RESTROOMS	\$22.84 / SF
SS-4	SOLID SURFACE	GRANITE	LEVANTINA	ANDINO WHITE / 3 CM	MODEL UNIT		\$10.50 / SF
WD-11	WOOD	REMOVED	REMOVED	REMOVED	REMOVED	REMOVED	
WD-12	WOOD	WOOD BLOCKS	BEECH CREEK TIMBER	8" X 8" RECLAIMED WOOD BLOCKS	KITCHEN ISLAND	SEE ELEVATIONS	BEECH CREEK TIMBER \$76,789.4277
WS-1	WOOD STAIN	PER GC	PER GC	TO MATCH WDV-1 (SEE CEILING FINISH SCHEDULE)		SUBMIT SAMPLE FOR DESIGNER APPROVAL	

- MILLWORK GENERAL NOTES**
- ALL MILLWORK SHALL COMPLY WITH PROVISIONS OF THE ARCHITECTURAL WOODWORK INSTITUTE (AWI) QUALITY STANDARDS, MOST RECENT EDITION. WORK SHALL BE PERFORMED IN THE HIGHEST GRADE APPLICABLE.
 - PROVIDE SHOP DRAWINGS FOR ALL MILLWORK AND CABINETS BASED ON DRAWINGS AS WELL AS FIELD DIMENSIONS. PROVIDE SAMPLES OF FINISHES FOR APPROVAL PRIOR TO ORDERING AND/OR FABRICATION.
 - CABINET STYLE SHALL BE FLUSH OVERLAY, UNLESS NOTED OTHERWISE.
 - INSTALL STANDING AND RUNNING TRIM WITH MINIMUM NUMBER OF JOINTS POSSIBLE, USING FULL LENGTH PIECES. MITER CORNERS AND SCRIBE SMOOTH AT JAMBS. NO EXPOSED CUTS OR EDGES WILL BE ACCEPTABLE.
 - INSTALL MILLWORK PLUMBING LEVEL AND STRAIGHT. PROVIDE CONCEALED SHIMS AS REQUIRED WITH A MAXIMUM TOLERANCE OF 1/8" IN 8'-0" FOR PLUM AND LEVEL. SCRIBE AND CUT MILLWORK TO FIT ADJOINING CONSTRUCTION.
 - PROVIDE A FINISHED END PANEL AT ALL EXPOSED CABINET ENDS, UNLESS NOTED OTHERWISE.
 - MATERIAL GRAIN ON CABINETS, DRAWERS AND CABINET BASES SHALL BE CONSISTENT AND RUN IN THE SAME DIRECTION.
 - JOINTS IN STONE/SOLID SURFACE COUNTERTOPS SHALL BE BUTT JOINTS WITH MINIMAL SEALANT EXPOSED.
 - HARDWARE SHALL COMPLY WITH ANSI A108.8 AMERICAN NATIONAL STANDARD FOR CABINET HARDWARE. HINGERS SHALL BE PER NUMBER OF LEAF AS NOTED IN MANUFACTURER'S LITERATURE. WIDE "X" RUBBER SILENCERS.
 - ALL CABINETS TO BE FULL OVERLAY AND SET CLOSING. INTERIOR FINISH AND FILLERS TO MATCH EXTERIOR FINISH. FINISH LOWER CABINET DOORS TO EXTEND DOWN TO HIDE LOWER CABINET LEGS.



CROSBY DESIGN GROUP

Interior Design Firm

 1440 Dutch Valley Place

 Suite 755

 Atlanta, Georgia 30324

 404.872.9777 tel

 www.crosbydesigngroup.com

HISTORY	
DATE	DESCRIPTION

REVISIONS	

© COPYRIGHT 2015 CROSBY DESIGN GROUP

THIS DRAWING IS THE PROPERTY OF THE INTERIOR DESIGNER AND MAY NOT BE REPRODUCED OR USED WITHOUT THE WRITTEN PERMISSION.

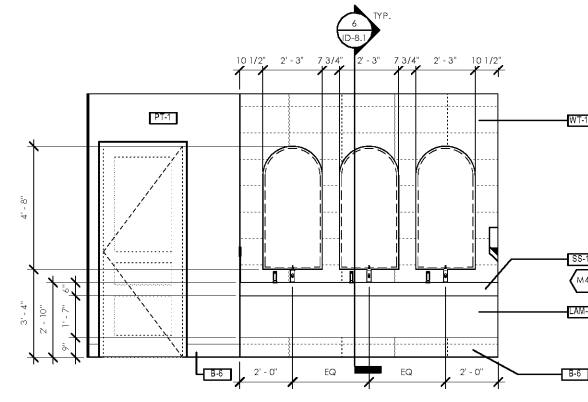

1 ELEVATION - FITNESS RESTROOMS SINK WALL (TYPICAL)
3/8" = 1'-0"

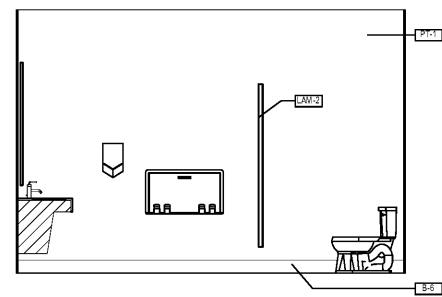

2 ELEVATION - FITNESS WOMEN'S RESTROOM (A)
3/8" = 1'-0"

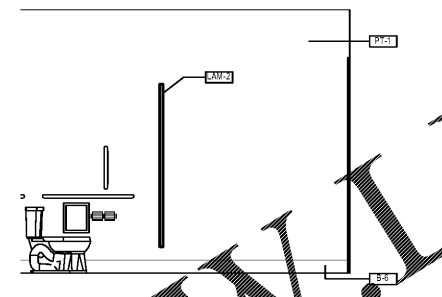

3 ELEVATION - FITNESS WOMEN'S RESTROOM (B)
3/8" = 1'-0"

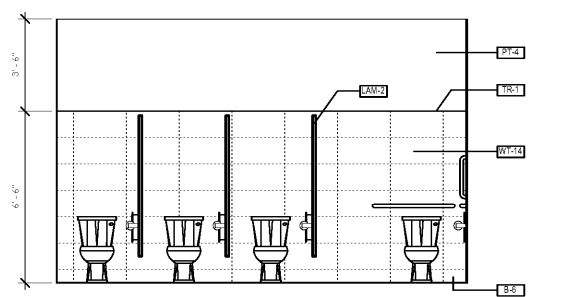

4 ELEVATION - FITNESS WOMEN'S RESTROOM (C)
3/8" = 1'-0"

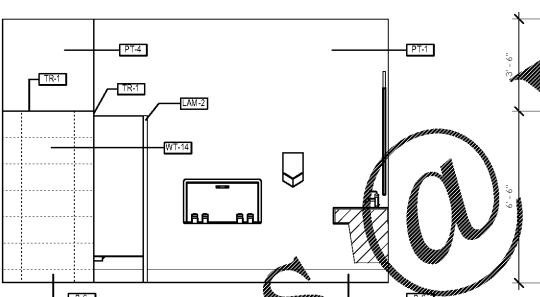

5 ELEVATION - FITNESS MEN'S RESTROOM (A)
3/8" = 1'-0"

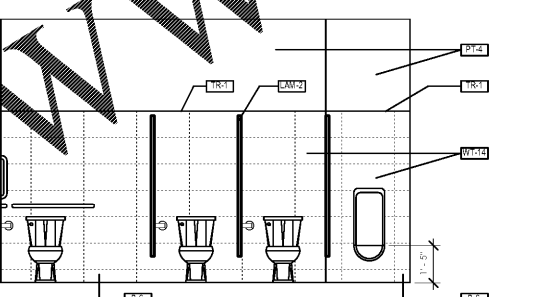

6 ELEVATION - FITNESS MEN'S RESTROOM (B)
3/8" = 1'-0"

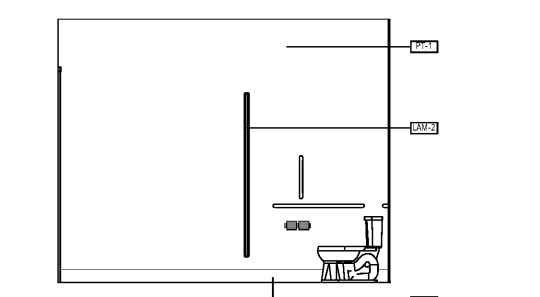

7 ELEVATION - FITNESS MEN'S RESTROOM (C)
3/8" = 1'-0"

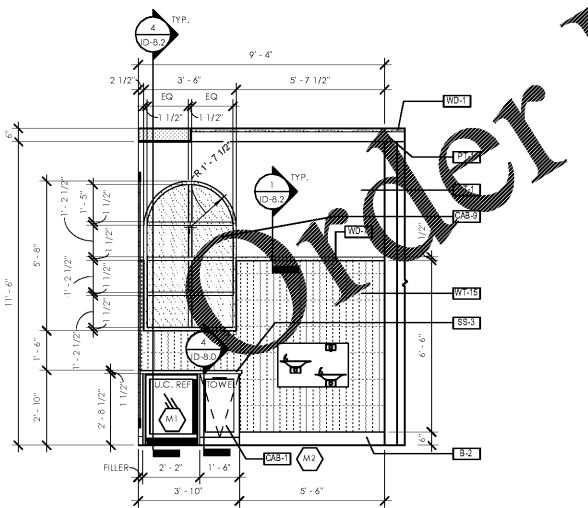

9 ELEVATION - FITNESS MILLWORK
3/8" = 1'-0"

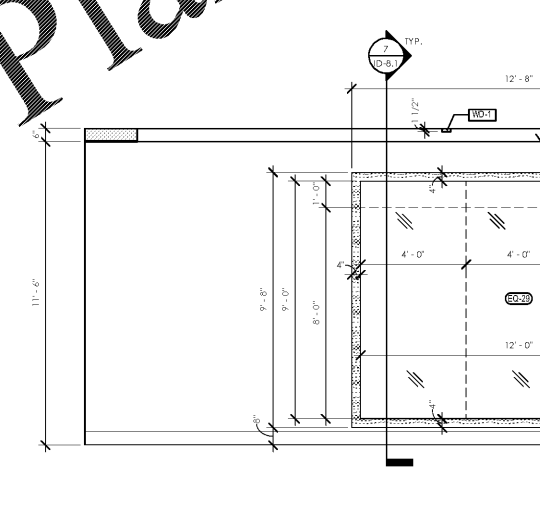

10 ELEVATION - FITNESS MIRROR WALL (A)
3/8" = 1'-0"

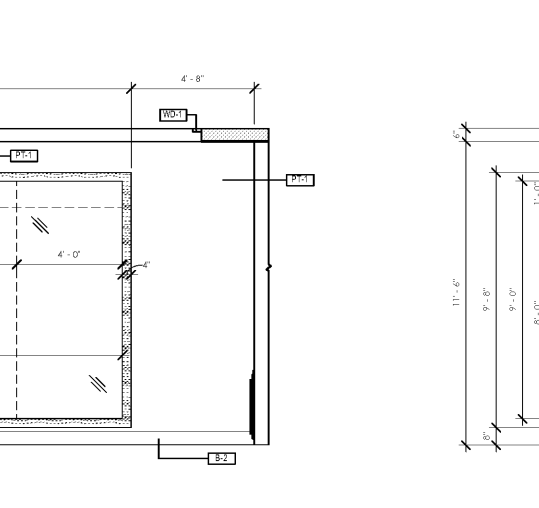

11 ELEVATION - FITNESS MIRROR WALL (B)
3/8" = 1'-0"

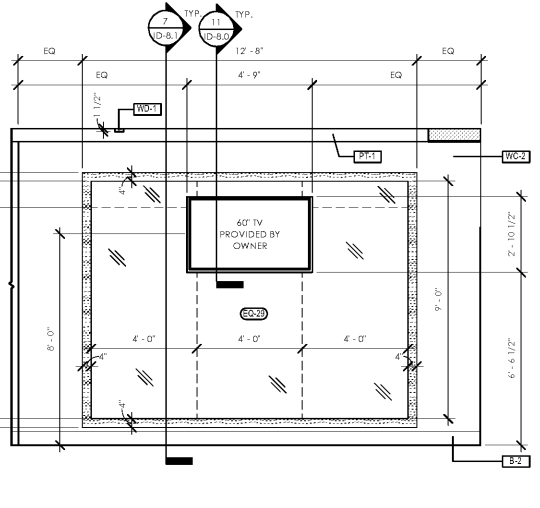

11 ELEVATION - FITNESS MIRROR WALL (B)
3/8" = 1'-0"

Order Plans @

WWW.LDILine.com

FOUNDRY33
CHATTANOOGA, TN

DATE: 06/01/2020

FOUNDRY33

SHEET TITLE: **ELEVATION**

SHEET NO.: **ID-7.5**

NOT ISSUED FOR CONSTRUCTION
 ISSUED FOR CONSTRUCTION