

SIDE VIEW

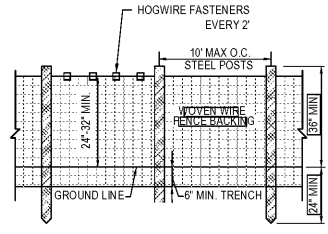

FRONT VIEW

SPECIAL NOTES:
 1. SILT FENCE FABRIC SHALL BE PER TABLE SB-1 FROM THE LATEST ALABAMA EROSION CONTROL HANDBOOK.
 2. USE D.O.T. APPROVED WOVEN WIRE FENCE.
 3. USE 5' MIN. STEEL POSTS (1.3 LB/FT MIN.).

NOTES:
 1. THE WOVEN WIRE FENCING SHALL BE FASTENED TO THE UPSTREAM SIDE OF POSTS BY STAPLES OF WIRE TIES.
 2. GEOTEXTILE FABRIC SHALL BE SECURELY FASTENED TO THE WOVEN WIRE FENCING.

MAINTENANCE SCHEDULE:
 REMOVE SEDIMENT DEPOSITS WHEN THEY REACH A DEPTH OF 15" OR 1/2 THE HEIGHT OF THE FENCE AS INSTALLED TO PROVIDE ADEQUATE STORAGE VOLUME FOR THE NEXT RAIN AND TO REDUCE PRESSURE ON THE FENCE. SHOULD THE FABRIC OR SILT FENCE COLLAPSE, TEAR, DECOMPOSE OR BECOME INEFFECTIVE, REPLACE IT PROMPTLY.

SB SILT FENCE - TYPE A
N.T.S.

ADEM

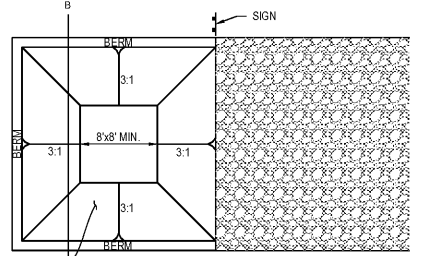

SECTION A

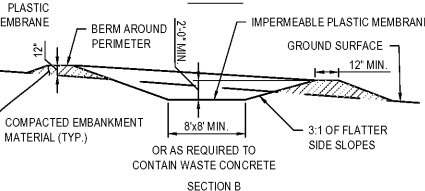

SECTION B

CONCRETE WASHOUT AREA INSTALLATION NOTES:

1. THE CONCRETE WASHOUT AREA SHALL BE INSTALLED PRIOR TO ANY CONCRETE PLACEMENT ON SITE.
2. SIGNS SHALL BE PLACED AT THE CONSTRUCTION ENTRANCE, AT THE WASHOUT AREA, AND ELSEWHERE AS NECESSARY TO CLEARLY INDICATE THE LOCATION OF THE CONCRETE WASHOUT AREA TO OPERATORS OF CONCRETE TRUCKS AND PUMP RIGS.
3. EXCAVATED MATERIAL SHALL BE UTILIZED IN PERIMETER BERM CONSTRUCTION.
4. IMPERMEABLE PLASTIC SHEETING SHALL BE 30 MIL TO PREVENT ANY TEARING, PUNCTURES, OR LEAKING.

CONCRETE WASHOUT AREA MAINTENANCE NOTES:

1. THE CONCRETE WASHOUT AREA SHALL BE REPAIRED AND ENLARGED OR CLEANED OUT AS NECESSARY TO MAINTAIN CAPACITY FOR WASTED CONCRETE.
2. AT THE END OF CONSTRUCTION, ALL CONCRETE SHALL BE REMOVED FROM THE SITE AND DISPOSED OF AT AN APPROVED WASTE SITE.
3. WHEN THE CONCRETE WASHOUT AREA IS REMOVED, THE DISTURBED AREA SHALL BE SEEDED AND MULCHED OR OTHERWISE STABILIZED.
4. INSPECT WEEKLY, DURING AND AFTER ANY STORM EVENT.

CONCRETE WASHOUT AREA
N.T.S.

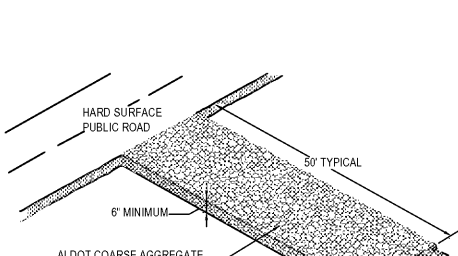

PLAN

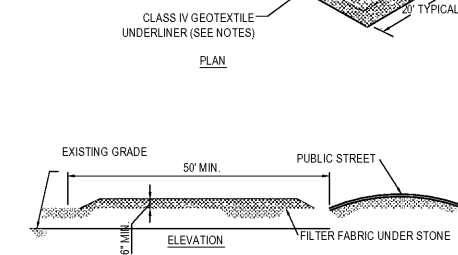

ELEVATION

SPECIAL NOTES:

1. A STABILIZED PAD OF CRUSHED STONE SPREAD OVER FILTER FABRIC SHALL BE LOCATED WHERE TRAFFIC WILL BE ENTERING OR LEAVING A CONSTRUCTION SITE TO OR FROM A PUBLIC STREET. THE STONE SHALL BE ALDOT GRADATION NO. 1 STONE. FILTER FABRIC SHALL BE NONWOVEN GEOTEXTILE CLASS IV OR EQUAL.
2. THE ENTRANCE SHALL BE MAINTAINED IN A CONDITION WHICH WILL PREVENT TRACKING OR FLOWING OF SEDIMENT ONTO PUBLIC STREETS OR EXISTING PAVEMENT. THIS MAY REQUIRE PERIODIC TOP DRESSING WITH ADDITIONAL STONE AS CONDITIONS DEMAND AND REPAIR AND/OR CLEANOUT OF ANY MEASURES USED TO TRAP SEDIMENT.
3. ALL SEDIMENT SPILLED, DROPPED, WASHED OR TRACKED ONTO PUBLIC STREETS MUST BE REMOVED IMMEDIATELY BY STREET CLEANING (NOT FLUSHING). WHEN NECESSARY, WHEELS MUST BE CLEANED TO REMOVE SEDIMENT PRIOR TO ENTERING A PUBLIC STREET. WHEN WASHING IS REQUIRED, IT SHALL BE DONE ON AN AREA STABILIZED WITH CRUSHED STONE WHICH DRAINS INTO A SEDIMENT TRAP OR BASIN.
4. IF THE PAD SLOPE TOWARDS THE ROAD EXCEEDS 2%, A DIVERSION RIDGE 6" - 8" HIGH WITH 3:1 SIDE SLOPES MUST BE CONSTRUCTED ACROSS THE FOUNDATION APPROXIMATELY 15' AWAY FROM THE ROAD AND DRAIN INTO A SEDIMENT TRAP OR BASIN.

CEP CONSTRUCTION EXIT PAD
N.T.S.

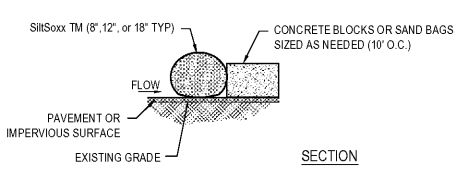

SECTION

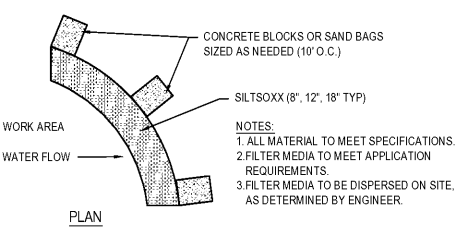

PLAN

SS Siltsoxx™ for Sediment Control on Pavement
N.T.S.

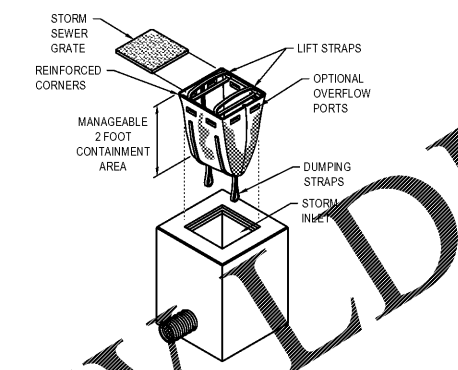

TP2 SANDY SACK
N.T.S.

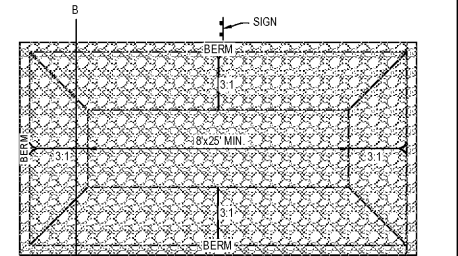

SECTION A

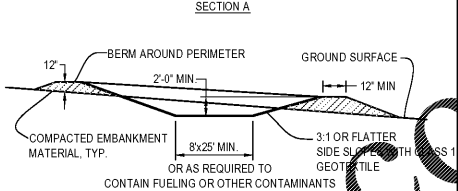

SECTION B

FUELING AND MAINTENANCE AREA INSTALLATION NOTES:

1. THE FUELING AND MAINTENANCE AREA SHALL BE INSTALLED PRIOR TO ANY CONSTRUCTION ON SITE. SIGNS SHALL BE PLACED AT THE CONSTRUCTION ENTRANCE, AT THE FUELING AND MAINTENANCE AREA, AND ELSEWHERE AS NECESSARY TO CLEARLY INDICATE THE LOCATION OF THE FUELING AND MAINTENANCE AREA TO OPERATORS OF VEHICLES AND EQUIPMENT.
2. EXCAVATED MATERIAL SHALL BE UTILIZED IN PERIMETER BERM CONSTRUCTION.

FUELING AND MAINTENANCE AREA MAINTENANCE NOTES:

1. THE FUELING AND MAINTENANCE AREA SHALL BE REPAIRED AND ENLARGED OR CLEANED OUT AS NECESSARY TO MAINTAIN CAPACITY FOR WASTED CONCRETE.
2. AS NECESSARY, ALL CONTAMINANTS SHALL BE REMOVED FROM THE SITE AND DISPOSED OF AT AN APPROVED WASTE SITE.
3. WHEN THE FUELING AND MAINTENANCE AREA IS REMOVED, THE DISTURBED AREA SHALL BE SEEDED AND MULCHED OR OTHERWISE STABILIZED.
4. INSPECT WEEKLY, DURING AND AFTER ANY STORM EVENT.

FUELING AND MAINTENANCE AREA
N.T.S.

LBVD, Inc.
Civil and Structural Engineers
1100 South College St, Suite 201
Auburn, AL 36832
Phone: (334) 734-0403
Fax: (334) 734-0403
PROJECT NO. 502-20-009
© Copyright 2020
These drawings and design intent are the sole property of LBVD, Inc. which may not be reproduced without written permission.

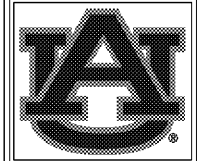

Facilities Management
1161 West Samford Avenue
Auburn University, AL 36849
Phone: (334) 844-4810
Fax: (334) 844-9458
Safety is our first priority.
Think Safety. Act Safely.

No.	Revision	Date
-	-	00/00/00



JMR+H Architecture, P.C.
446 Greer Avenue
Montgomery, AL 36104
Phone: (334) 420-5672
Fax: (334) 420-5662
JMR+H Project Number: 19-968
Drawn By: DT

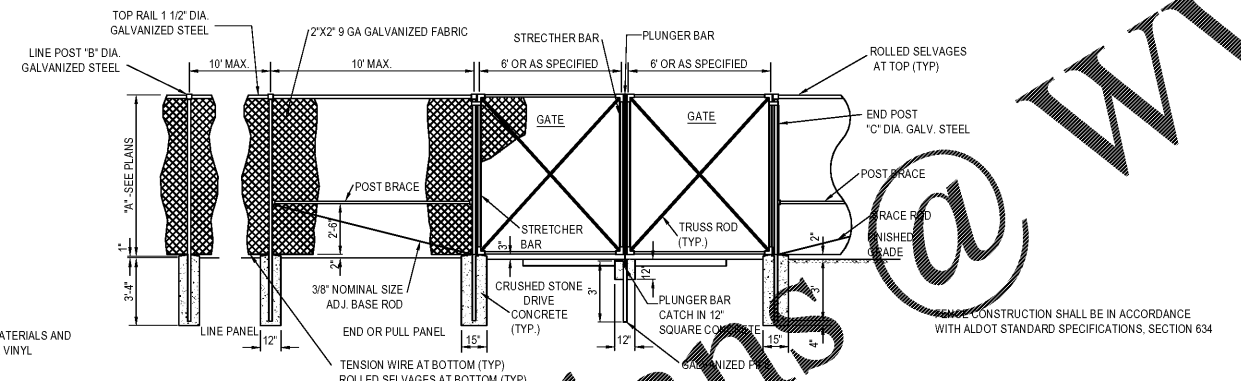

TEMPORARY CONSTRUCTION FENCING
N.T.S.

FINISH NOTE:
ALL FENCING FABRIC, FRAME MATERIALS AND ACCESSORIES SHALL BE BLACK VINYL COATED.

"A"	"B"	"C"
HEIGHT	LINE POST	END POST
4'	2.375" DIA.	2.5" DIA.
6'	2.375" DIA.	2.5" DIA.
8'	2.5" DIA.	3.0" DIA.

MAINTENANCE SCHEDULE:
REMOVE SEDIMENT DEPOSITS PROMPTLY AFTER IT HAS ACCUMULATED TO 1/2 OF THE ORIGINAL CAPACITY. TAKING CARE NOT TO UNDERMINE THE ENTRENCHED WATTLES. INSPECT PERIODICALLY FOR DETERIORATION OR DAMAGE FROM CONSTRUCTION ACTIVITIES. REPAIR DAMAGED BARRIER IMMEDIATELY.

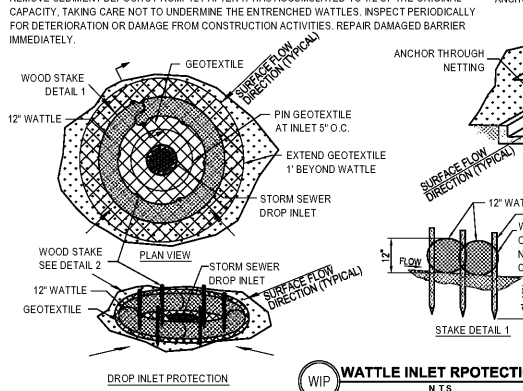

WIP WATTLE INLET PROTECTION
N.T.S.

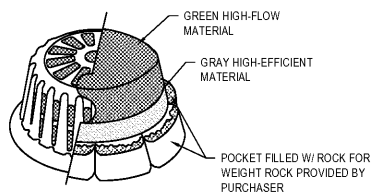

ISOMETRIC VIEW
SHOWN WITH ROADWAY PROJECTS FILTER HAT

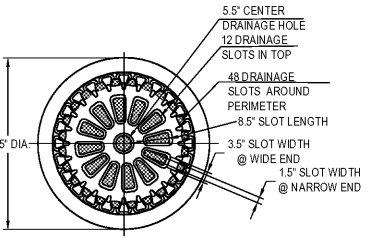

PLAN VIEW

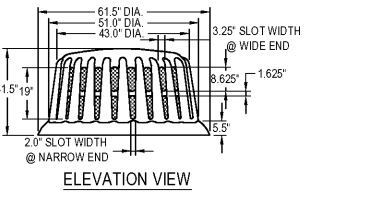

ELEVATION VIEW

REPLACEMENT FILTERS: MODEL # R-140
FRAME MATERIAL: BLACK 0.25" HMWPE
FILTER FABRIC MATERIAL: REFER TO SPEC
ROUND FRAME & FILTER ASSEMBLY
MODEL # R-100A

IP1

FILTER OPTIONS
FILTER HAT IS AVAILABLE IN THREE OPTIONS:
1) ALL HIGH-FLOW MATERIAL
2) ALL HIGH-EFFICIENCY MATERIAL
3) HIGH-FLOW MATERIAL ON TOP HALF OF HAT, HIGH-EFFICIENCY MATERIAL ON BOTTOM HALF (THIS FILTER COVER IS RECOMMENDED FOR ALL ROADWAY PROJECTS.)
IT IS THE PURCHASERS RESPONSIBILITY TO PURCHASE APPROPRIATE FILTER HAT. PURCHASER SHALL PROVIDE ROCK FOR FILTER POCKETS.

FILTER HAT INSTALLATION
FILTER HAT SLIDES DIRECTLY OVER FILTER FRAME. TO KEEP FILTER FRAME IN PLACE OVER STORM STRUCTURE, ROCK POCKETS ARE SEWN DIRECTLY INTO FILTER HAT MATERIAL. EVERY FILTER HAT COMES IN ONE PIECE FOR EASY INSTALLATION.

MAINTENANCE
ALL TEMPORARY EROSION, SEDIMENTATION, & POLLUTION CONTROL PRACTICES SHOULD BE INSPECTED DAILY. CONTRACTOR SHALL REMOVE SEDIMENT AND DISPOSE OF IN A PROPER MANNER. INSPECT R-100A DAILY FOR CUTS, ABRASIONS, AND PROPER INSTALLATION. REPLACE OR REPOSITION AS NECESSARY.

SPECIFICATIONS
FILTER FABRIC SILT-SAVER HAT SHALL BE BASED ON DESIGN PROFESSIONAL'S SPECIFICATIONS.

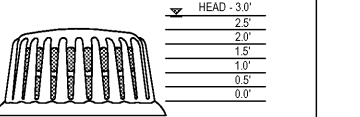

FRAME & FILTER DISCHARGE ANALYSIS

HEAD (FT)	EQUATION USED	OPENING AREA (SF)	FRAME FLOW (CFS)	AREA (SF)	FILTER FLOW (CFS)	FILTERED (CFS)
0.5	O	2.1	7	6	2	
1.0	O	3.9	19	12	3	
1.5	O	7.0	41	18	5	
2.0	O	8.0	54	24	7	
2.5	O	9.2	70	30	9	
3.0	O	9.2	77	—	77	

DUE TO NARROW SLOT, A TRANSITION WILL OCCUR BETWEEN WEIR AND ORIFICE CONDITIONS. ORIFICE FLOW WILL PROVIDE A MORE CONSERVATIVE ESTIMATE OF FLOW, THEREFORE THE LESSER OF THE ORIFICE AND WEIR FLOWS WILL BE USED FOR EACH STAGE CALCULATION.

FILTER MATERIAL ALLOWS 129 gpm/SF OR 0.29cfs/SF
ORIFICE EQUATION (O) = $Q = 0.6A(2gh)^{0.5}$
P = FEET PERIMETER
h = HEAD IN FEET
Q = CAPACITY IN cfs
A = FREE OPEN AREA OF FRAME
g = 32.2 FEET-PER-SECOND/SECOND

SILT SAVER
N.T.S.

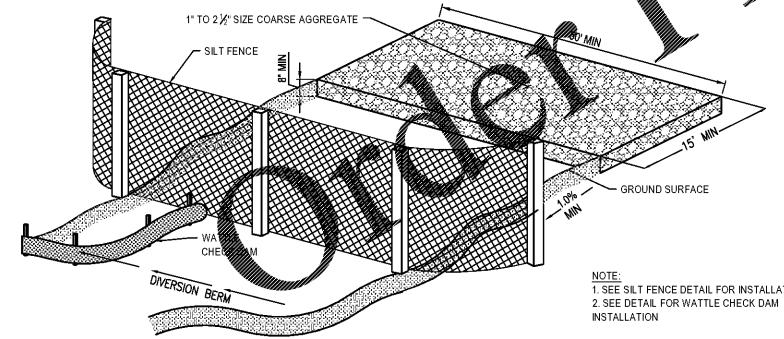

VW VEHICLE WASHDOWN AREA
N.T.S.

Auburn University Building
Ham Wilson Arena Renovations
Project Number 19-451

SHEET TITLE:
EROSION CONTROL
DETAILS

DRAWN BY:
WLH
CHECKED BY:
CLT
DATE:
JANUARY 21, 2021
FILE NUMBER:
-
PROJECT NUMBER:
19-451
SHEET NUMBER: