

**8** ROOF PENETRATION  
NTS

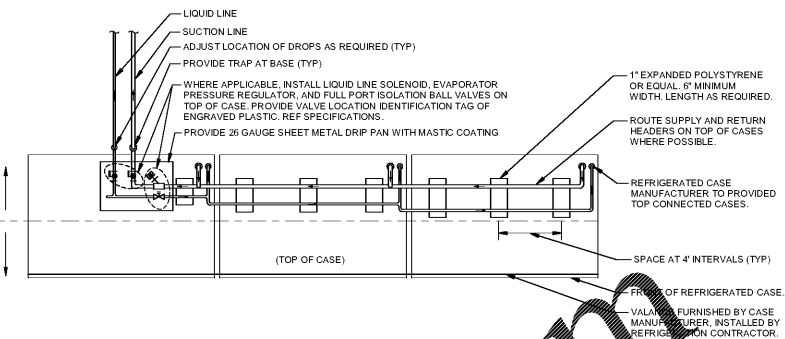

**7** REFRIGERATION PIPE ROUTING FOR TOP FEED CASES  
NTS

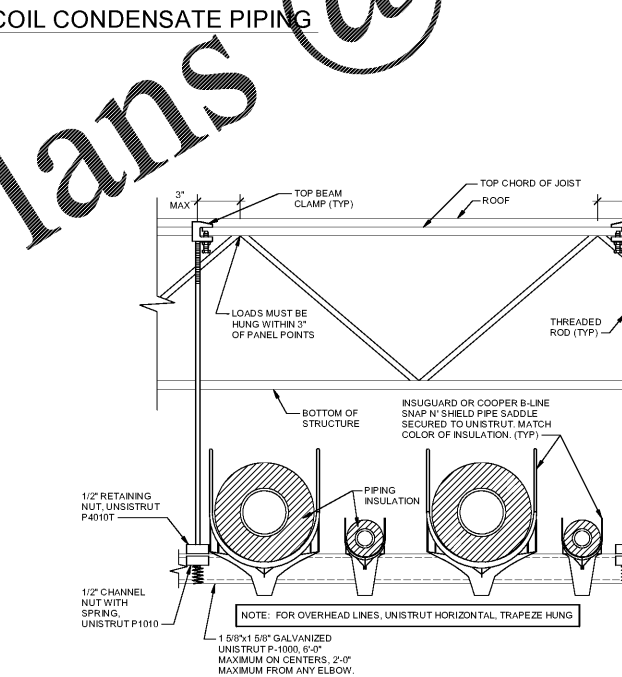
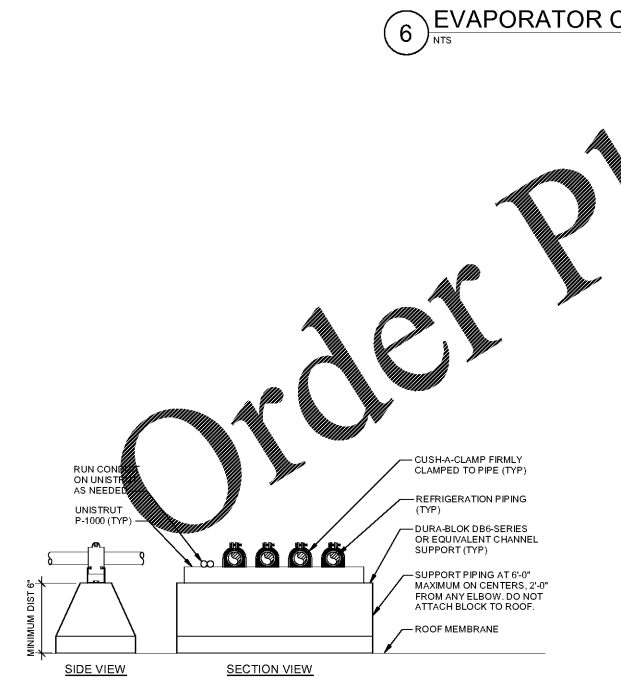
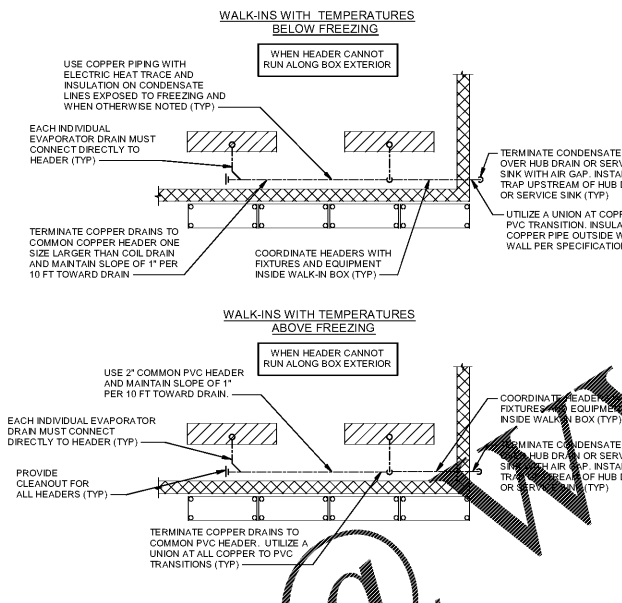
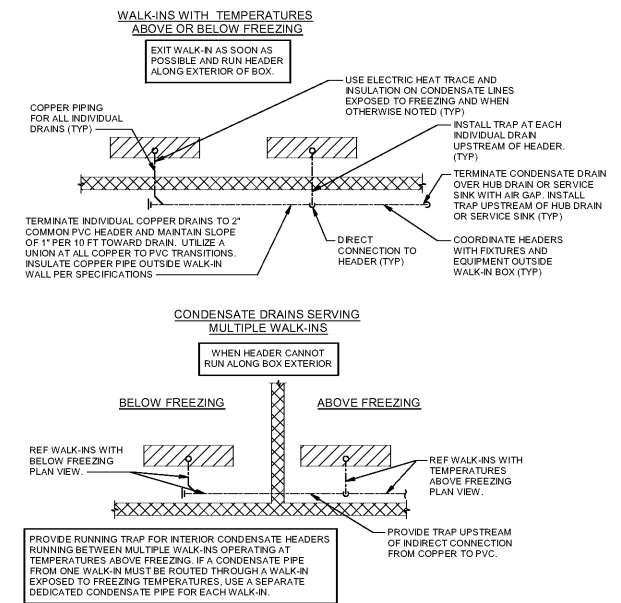

**6** EVAPORATOR COIL CONDENSATE PIPING  
NTS

**4** REFRIGERATION PIPING SUPPORT (ON ROOF)  
NTS

**3** HORIZONTAL REFRIGERANT LINE SUPPORT  
NTS

**2** INTERMEDIATE SUCTION LINE TRAP  
NTS

**5** EVAPORATOR FAN/COIL UNIT WITH CONTROL VALVES  
NTS

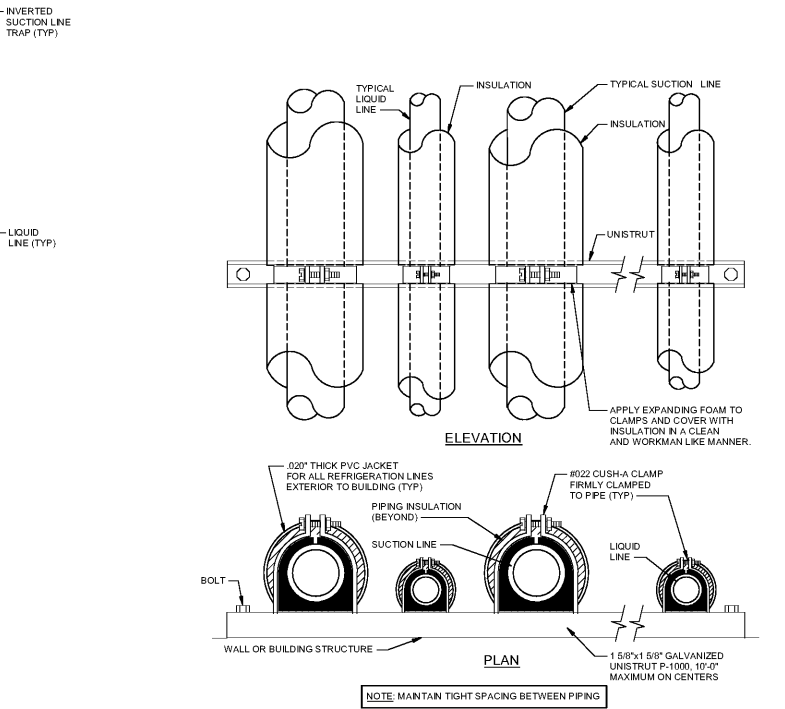

**1** VERTICAL REFRIGERANT LINE SUPPORT  
NTS

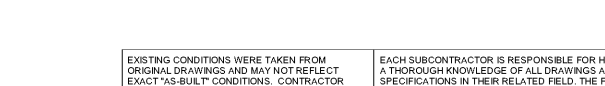
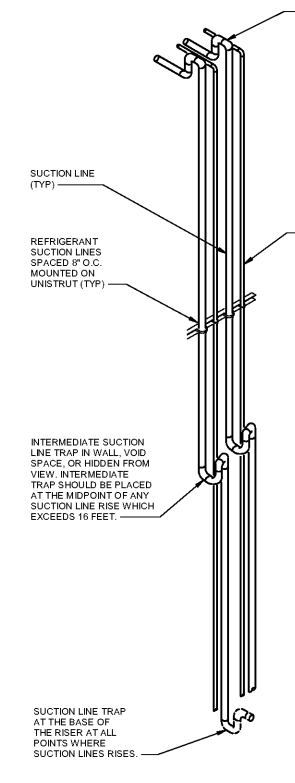

EXISTING CONDITIONS WERE TAKEN FROM ORIGINAL DRAWINGS AND MAY NOT REFLECT EXACT \"AS-BUILT\" CONDITIONS. CONTRACTOR SHALL FIELD VERIFY ALL EXISTING CONDITIONS PRIOR TO SUBMITTING FINAL BIDS. CONTRACTOR SHALL CAREFULLY COORDINATE NEW WORK AND DEMOLITION WITH ALL OTHER DISCIPLINES AND EXISTING CONDITIONS.  
EACH SUBCONTRACTOR IS RESPONSIBLE FOR HAVING A THOROUGH KNOWLEDGE OF ALL DRAWINGS AND SPECIFICATIONS IN THEIR RELATED FIELD. THE FAILURE TO ACQUAINT THEMSELVES WITH THIS KNOWLEDGE DOES NOT RELIEVE THE RESPONSIBILITY OF PERFORMING THE WORK PROPERLY. NO ADDITIONAL COMPENSATION SHALL BE ALLOWED BECAUSE OF CONDITIONS THAT OCCUR DUE TO FAILURE TO FAMILIARIZE WORKERS WITH THIS KNOWLEDGE.

STIPULATION FOR RIGOR  
THIS DRAWING AND ALL INFORMATION HEREON ARE THE PROPERTY OF HENDERSON ENGINEERS. ALL INFORMATION IS FOR INFORMATION ONLY AND IS NOT TO BE REPRODUCED OR TRANSMITTED IN ANY FORM OR BY ANY MEANS, ELECTRONIC OR MECHANICAL, INCLUDING PHOTOCOPYING, RECORDING, OR BY ANY INFORMATION STORAGE AND RETRIEVAL SYSTEM, WITHOUT THE WRITTEN PERMISSION OF HENDERSON ENGINEERS.  
AL 00832483-2489  
EXPIRES 1/01/2022

CONSULTANTS  
**HENDERSON ENGINEERS**  
6045 LEBLANCHE SUITE 300  
PRATTVILLE, AL 37137-6200  
TEL: (615) 242-2000 FAX: (615) 242-0001  
WWW.HENDERSONENGINEERS.COM  
AL 00832483-2489  
AL 00832483-2489 CA 2184E  
EXPIRES 1/01/2022

**Walmart**  
**PRATTVILLE, AL**  
1803 COBBE FORD ROAD  
STORE NO. 0083-2489  
JOB NUMBER: 2180806483  
PHOTO: REFRIGERANT

**ISSUE BLOCK**

NO.	DATE	DESCRIPTION

CHECKED BY: CCK  
DRAWN BY: SAK  
PROTO CYCLE: 01/29/21  
DOCUMENT DATE: 03/31/21

Professional Engineer Seal: No. 39490-E, State of Alabama, Mechanical, Professional Engineer, License No. 39490-E, expires 12/31/21.

03/30/2021  
**REFRIGERATION DETAILS**  
SHEET: R2

**Order Plans @**