

1 2 3 4 5 6

E

D

C

B

A

1

2

3

4

5

6

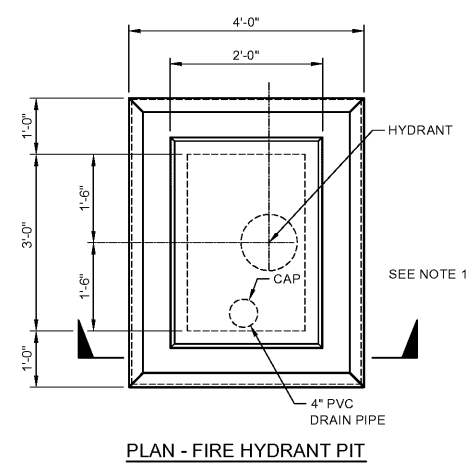

PLAN - FIRE HYDRANT PIT

NOTES (DETAIL C1)
 1. ELECTRICAL VAULTS: REMOVE VAULT. PLUG 4" DRAIN LINE. CAP ALL CONDUITS. AND CONSTRUCT REPAIR.

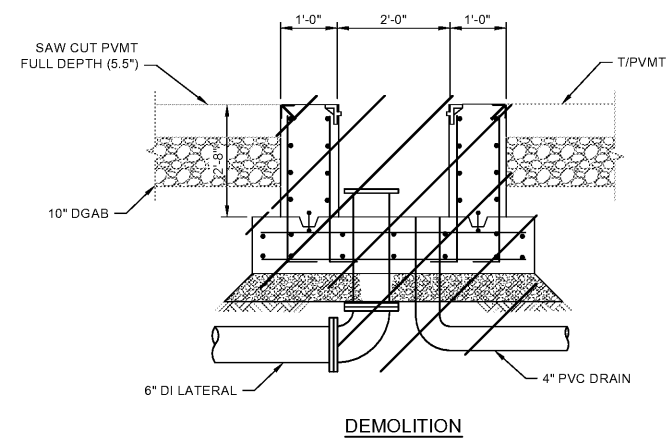

DEMOLITION

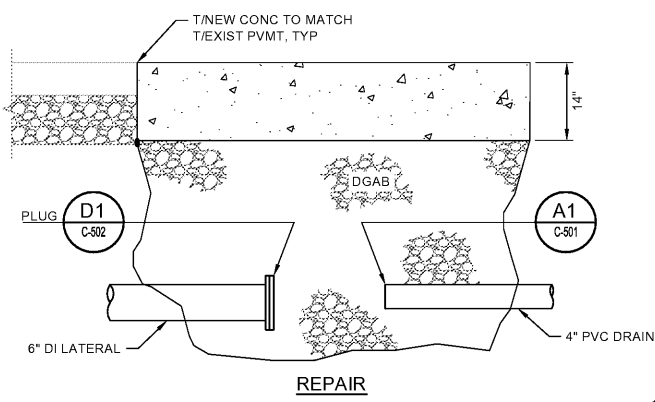

REPAIR

C1 DETAIL
 CD103 SCALE: NTS
 CD104A

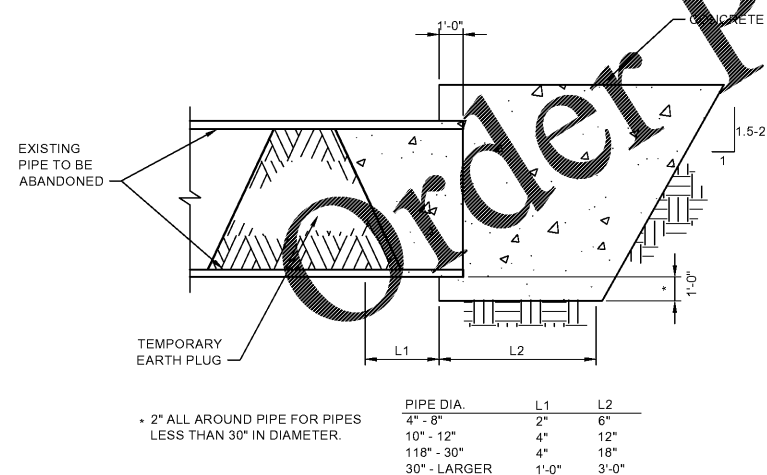

| PIPE DIA. | L1 | L2 |
|--------------|-------|-------|
| 4" - 8" | 2' | 6' |
| 10" - 12" | 4' | 12' |
| 14" - 30" | 4' | 18' |
| 30" - LARGER | 1'-0" | 3'-0" |

* 2" ALL AROUND PIPE FOR PIPES LESS THAN 30" IN DIAMETER.

A1 DETAIL
 SCALE: NTS

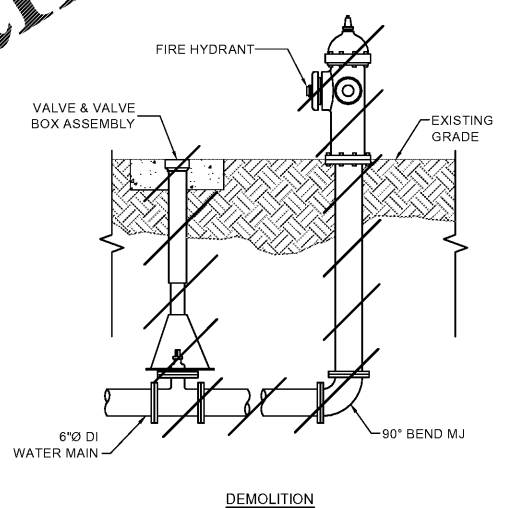

DEMOLITION

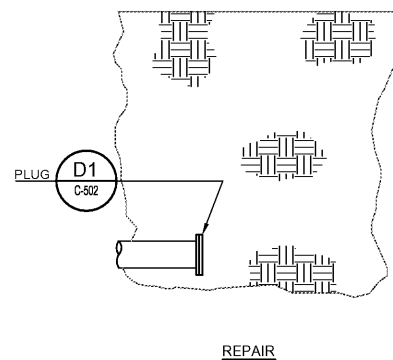

REPAIR

A3 DETAIL
 C-501 SCALE: NTS

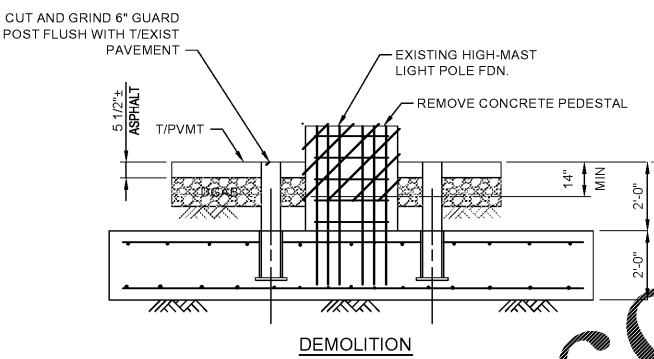

DEMOLITION

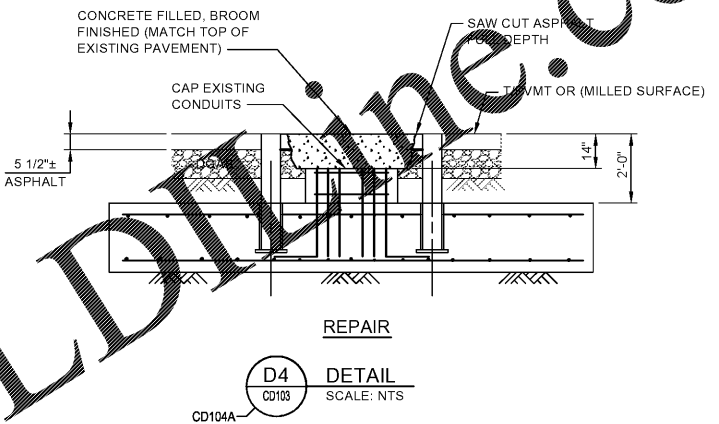

REPAIR

D4 DETAIL
 CD103 SCALE: NTS
 CD104A

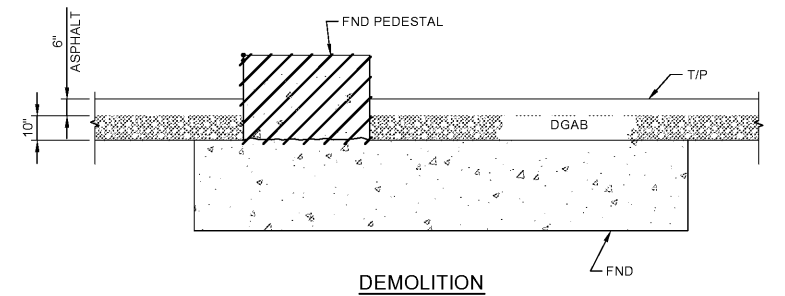

DEMOLITION

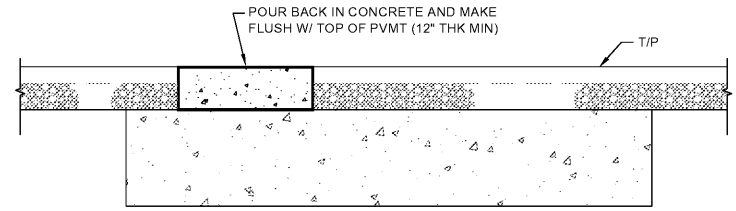

PAVEMENT PATCH

A5 DETAIL
 CD108 SCALE: NTS

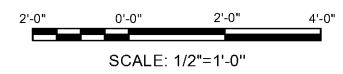

ISSUED FOR BID
 2021/02/03
 NOT TO BE USED FOR CONSTRUCTION

DRAWING SCALES SHOWN BASED ON 22"x34" DRAWING

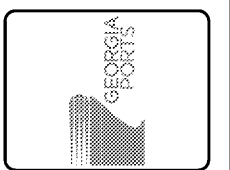

| Rev. | Date | Description |
|------|------------|-------------|
| 0 | 02/03/2021 | JHP |

GEORGIA PORTS AUTHORITY
 GCT CAPACITY IMPROVEMENTS - PHASE 2
 DETAIL SHEET 1 OF 1

| | | | |
|---------------|------------------|------------------|---------------|
| Designed by: | JHP | Date: | 0 |
| Dwn by: | RJM | MM Project No.: | 5531-254B |
| Reviewed by: | | GPA Project No.: | 1910-1011C |
| Submitted by: | MOFFATT & NICHOL | Drawing Scale: | AS NOTED |
| | | Plot Scale: | 1:1 (0 SHEET) |

2 EAST BRYAN ST., STE 501
 SAVANNAH, GA 31401
 912.231.0044
moffatt & nichol

SEAL

Sheet Reference No.
C-501
 INDEX: OF

File: Q:\SV\5531-254 2020 Capacity Improvements\600 CADD\1 Phase2\2020 Peak_Civil\5531254-C-501_Plan01.dwg, Plotted: 2/2/2021 7:07 PM by LEE, JAZMYN, Saved: 1/18/2021 12:32 PM by RMACCONNELL