

File Name: N:\D062\4046230 - CHARLOTTE, NC\DOCS\CAD\301 - FOUNDATION DETAILS.DWG Author: TOWLE, BRENDON Plot Date: 2/12/2021

Order Plans @ www.LDILine.com

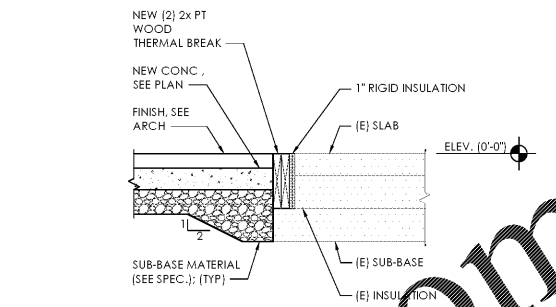

A3 Section
SCALE: 3/4"=1'-0"

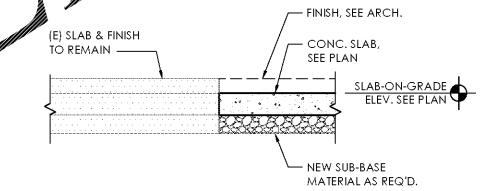

A2 Section
NO SCALE

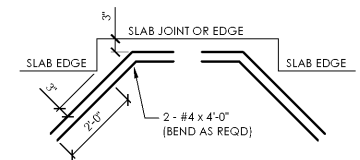

Short Slab Extension

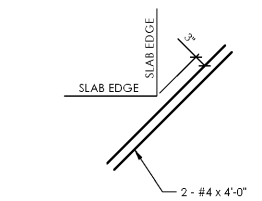

Re-entrant Corner

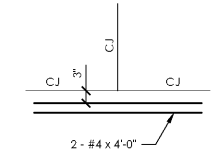

Discontinuous Control Joint

B1 Supplemental Slab-on-Grade Reinf
NO SCALE

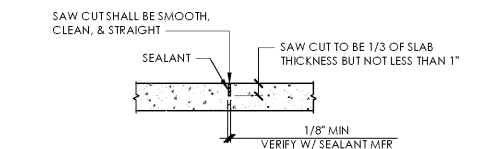

Control Joint

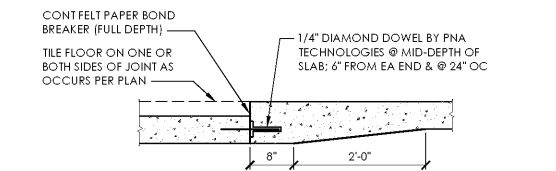

Construction Joint @ Concrete Step

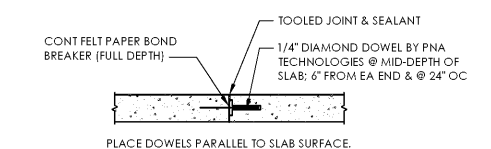

Construction Joint

A1 Typical Joint Details for Slabs-on-Grade
NO SCALE

| Issued: | Date: |
|---------------------|----------|
| A Client Review Set | 01/21/21 |
| B Permit Set | 02/03/21 |
| C Bid Set | 02/12/21 |
| D | |

| Revisions: | Date: |
|------------|-------|
| 1 | |
| 2 | |
| 3 | |
| 4 | |
| 5 | |
| 6 | |
| 7 | |
| 8 | |
| 9 | |

DO NOT SCALE PLANS
Copying, Printing, Software and other processes required to produce these prints can stretch or shrink the actual paper or layout. Therefore, scaling of this drawing may be inaccurate. Contact ms consultants with any need for additional dimensions or clarifications.

ms consultants, inc.
engineers, architects, planners
5444 Wade Park Blvd.
Suite 160
Raleigh, NC 27607-4299
phone 919.772.5565
fax 919.779.2308

DRAWN BY: MLU
REVIEWED BY: DMS

Seal ENGINEER FIRM LICENSE #C-3239

PROFESSIONAL OF RECORD:
CRAIG E. METZGER No. 044723
EXP. DATE: 12/31/21

ALDI Inc.
1985 Old Union Church Road
Salisbury, NC 28146
(704) 642-0022
(704) 642-0078 fax

ALDI Inc.
Store No. 87
2526 Freedom Dr
Charlotte, NC 28208
Mecklenburg County
Project Name & Location:

| Foundation Details | |
|-------------------------|----------------------|
| Drawing Name: | |
| Prototype Rls. 06/03/20 | Project No. 40452-30 |
| Type 100x154 FMR | |
| | S-301 |
| Scale: As Noted | Drawing No. |

D

C

B

A

1

2

3