

Order Plans @

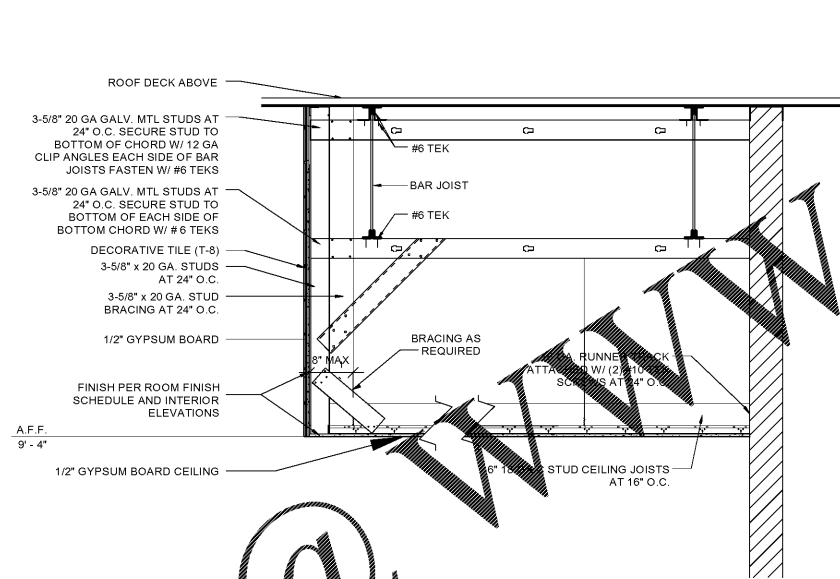

7 SECTION @ BULKHEAD
 3/4" = 1'-0"

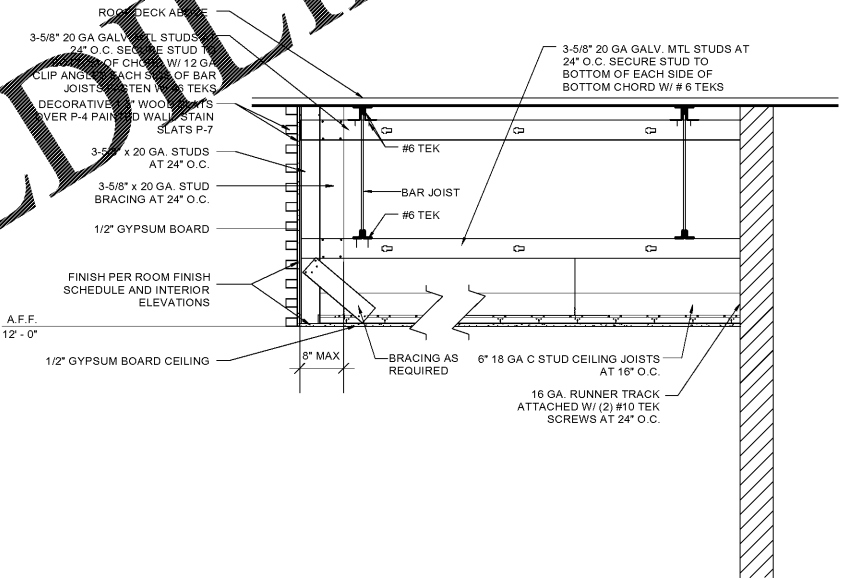

6 SECTION @ BULKHEAD
 3/4" = 1'-0"

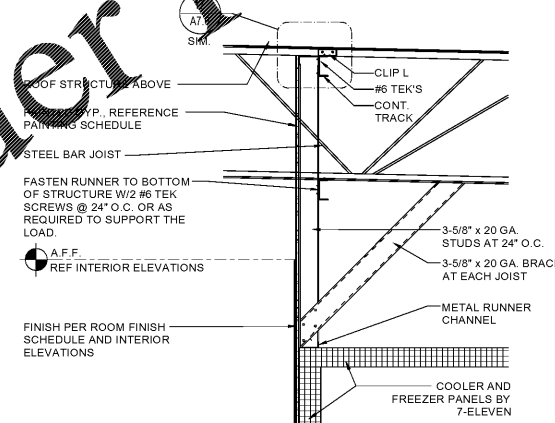

4 SECTION @ COOLER WALL
 3/4" = 1'-0"

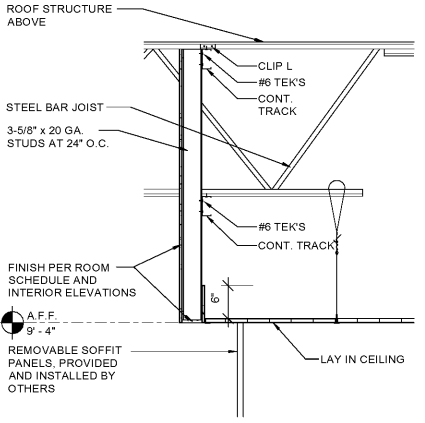

3 SECTION @ BULKHEAD
 3/4" = 1'-0"

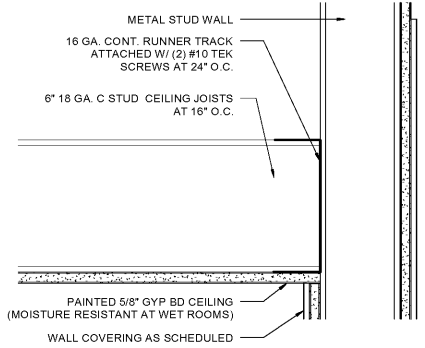

2 CEILING DETAIL
 3" = 1'-0"

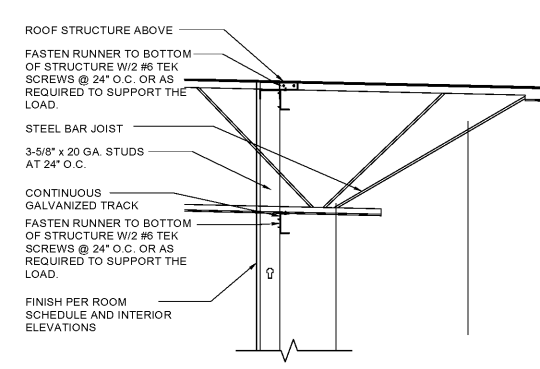

1 TYP. PARTITION TO DECK DETAIL
 3/4" = 1'-0"

5 NOT USED

WWW.LDOnline.com

1925 Prospect Ave.
 Orlando, FL 32814
 P (407) 661-9100
 P (407) 661-9101
 www.ep.com
 Florida Corporate Certificate #AA 000626

4
Enhaci & Peterson
 Architects Engineers Planners

CLIENT NAME
BLACKFIN PARTNERS INVESTMENTS, INC.
 4400 PCA BLVD, SUITE 600
 PALM BEACH GARDENS, FL 33410

PROJECT NAME
7-ELEVEN #41795 - OCALA, FL
 9000 BLOCK OF SE MARICAMP ROAD
 OCALA, FL 34470

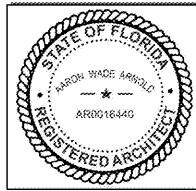

PROJECT NO.	220035
DATE	12/17/2020
DRAWN	ZNR
CHECKED	Page 10/24

RELEASE	
---------	--

A2.3.1