

01 ROOFTOP UNIT DETAIL
SCALE = NONE

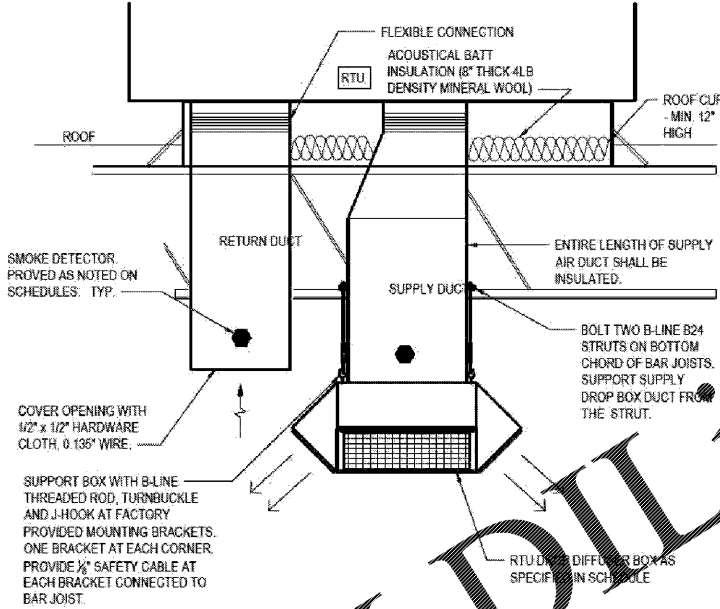

02 DROP BOX DETAIL
SCALE = NONE

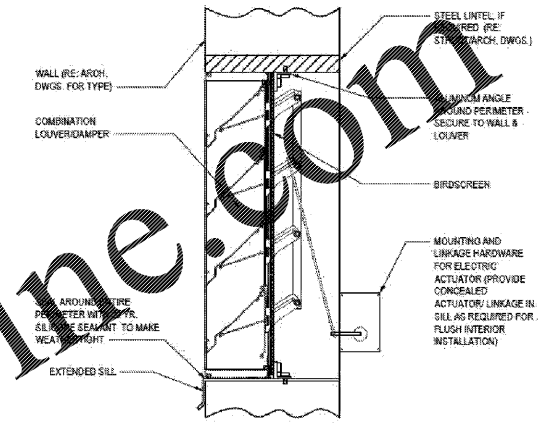

03 COMBINATION LOUVER/DAMPER DETAIL
SCALE = NONE

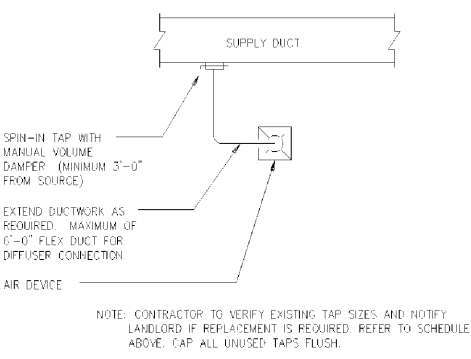

04 DIFFUSER CONNECTION
SCALE = NONE

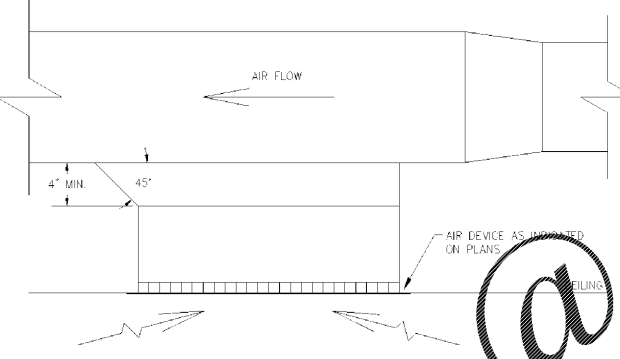

05 RETURN/EXHAUST GRILLE DETAIL
SCALE = NONE

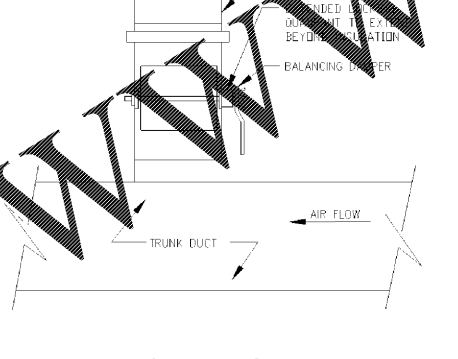

06 BRANCH TAKE-OFF DETAIL
SCALE = NONE

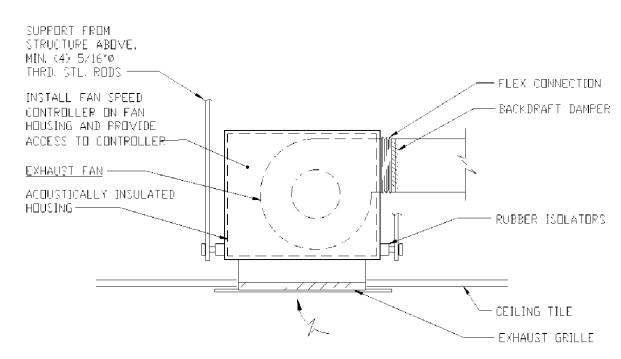

07 INLINE EXHAUST FAN DETAIL
SCALE = NONE

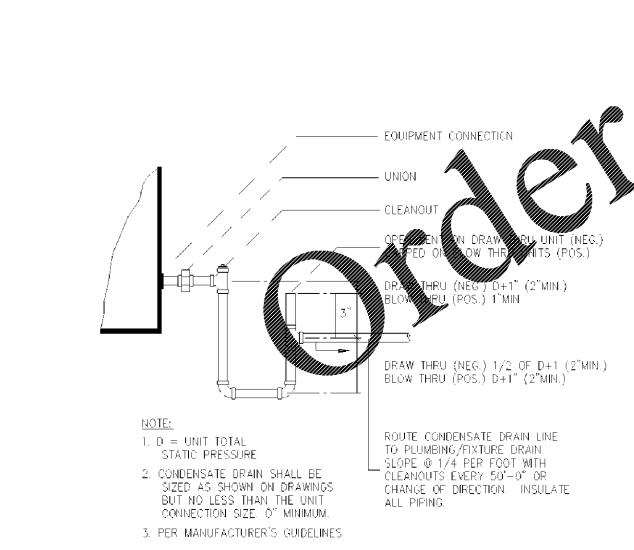

08 CONDENSATE DRAIN PIPING DETAIL
SCALE = NONE

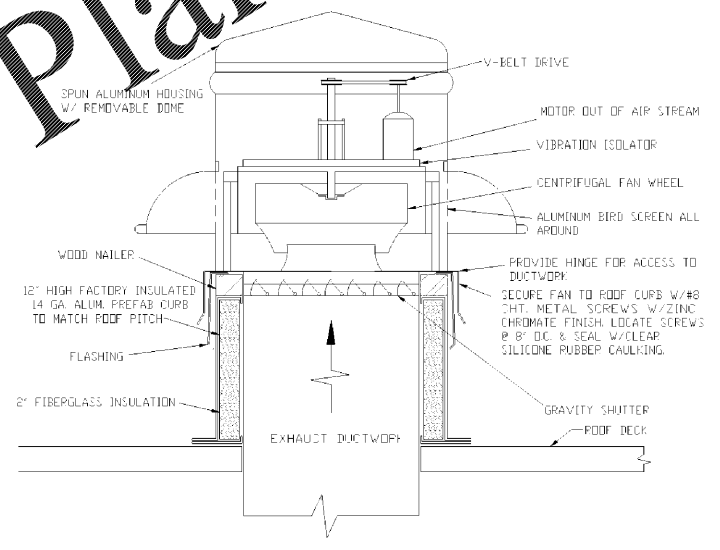

09 DOWNBLAST EXHAUST FAN DETAIL
SCALE = NONE

Order Plans @

WWW.IDLINE.com



1925 Prospect Ave.
Orlando, FL 32814
P (407) 661-9100
F (407) 661-9101
www.c-p.com
Florida Corporate Certificate #AA 0006538

Calderi & Peterson
Architects Engineers Planners
ORLANDO • PHILADELPHIA

Cross Development
4336 Marsh Ridge
Carrollton, TX 75010

Caliber Collision Five Forks (161)
1215 East Bay Rd.
Greenville, SC 29607

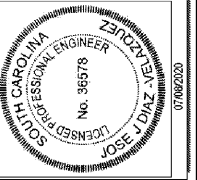

PROJECT NO.	220007
DATE	07/08/2020
DRAWN BY	BK
CHECKED BY	EAC

BID SET 10/28/2020

M3.0