

CASED OPENING
3'-1"

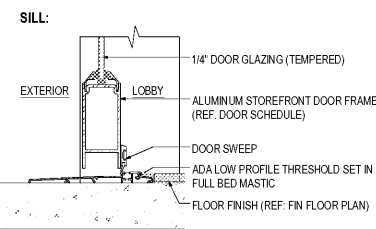

STOREFRONT
3'-1"

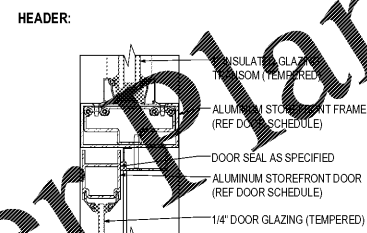
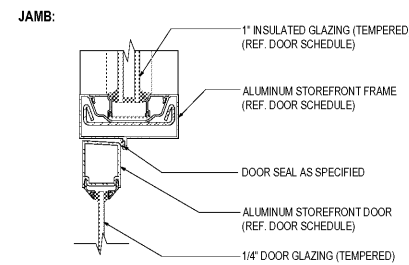
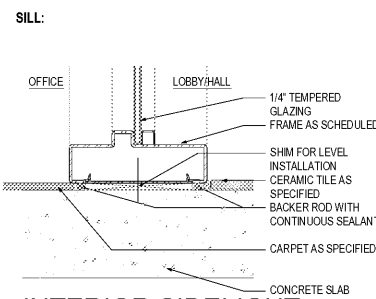
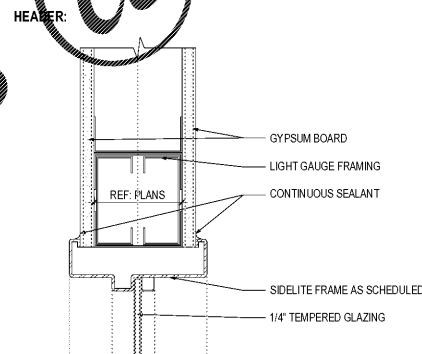
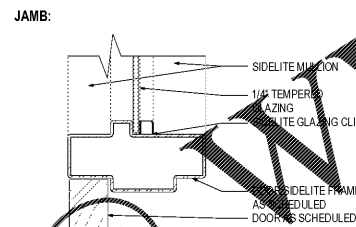
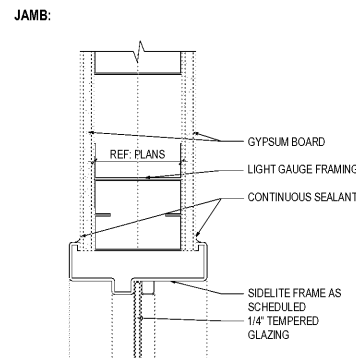

INTERIOR SIDELIGHT
3'-1"

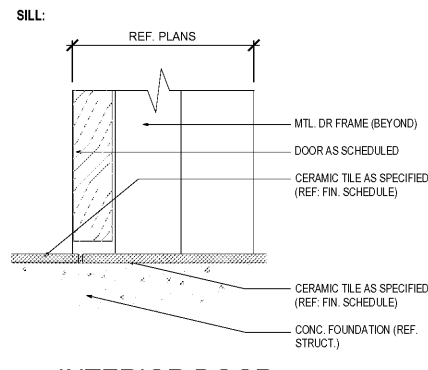
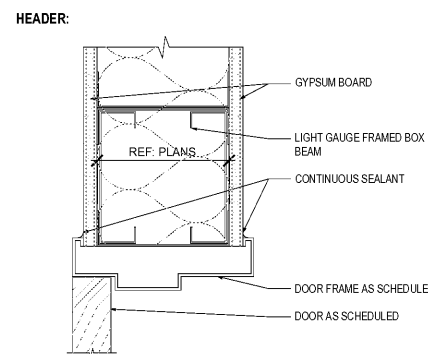
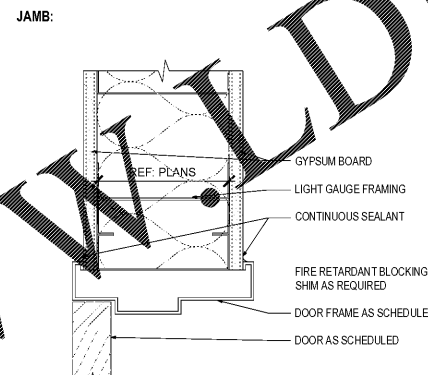

INTERIOR DOOR
3'-1"

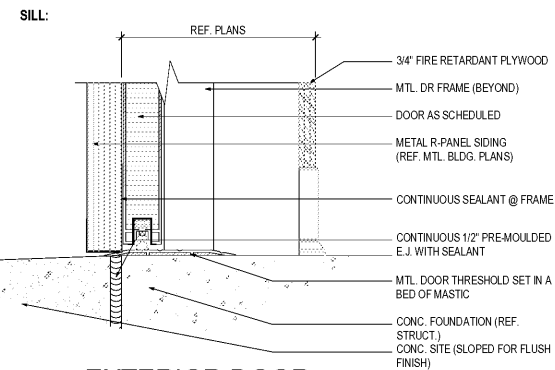
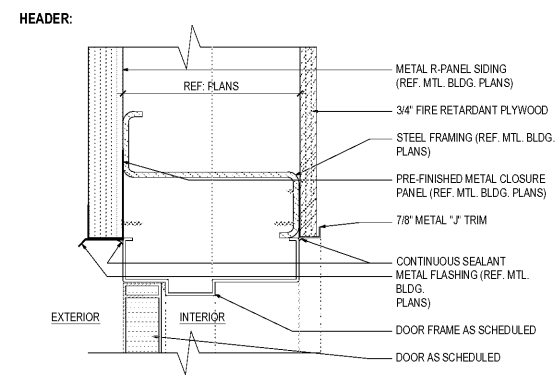
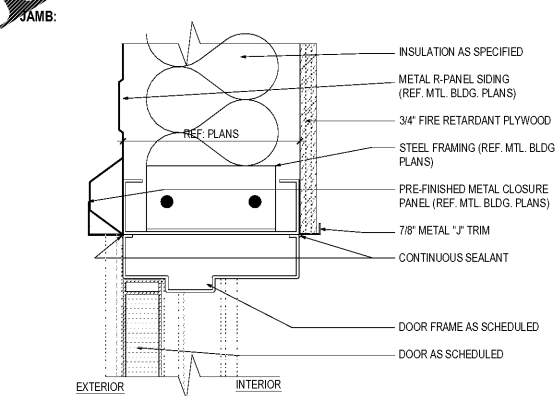

EXTERIOR DOOR
3'-1"

BID SET 10/28/2020

Order Plans

@

WWW.DILine.com

1925 Prospect Av.
Orlando, FL 32814
P (407) 661-9100
F (407) 661-9101
www.cp.com
Florida Corporate Certificate #AA C006526

Calderi & Peterson
Architects Engineers Planners
ORLANDO • PHILADELPHIA

CLIENT NAME
Cross Development
4536 MacArthur Blvd.
Carrilton, TX 75010

PROJECT NAME
Caliber Collision Five Forks (161)
1215 East Buller Rd.
Greenville, SC 29607

SHEET TITLE
Door & Window Details

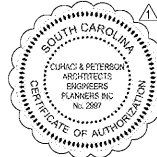

PROJECT NO.	2200857
DATE	07/08/2020
DRAWN	JJ
CHECKED	CD

RELEASE	
PERMIT COMMENTS RESPONSE	08/22/2020

A6.2