

05 PEMB EAVE DETAIL
1-1/2" = 1'-0"

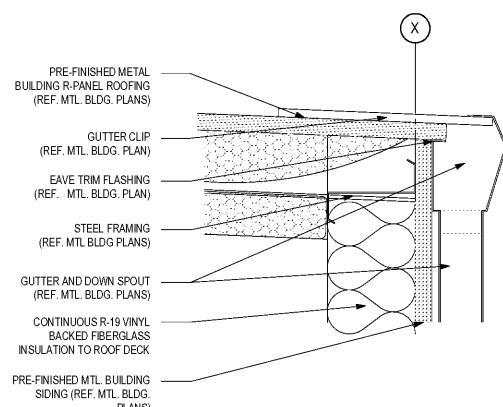

04 PEMB GUTTER DETAIL
1-1/2" = 1'-0"

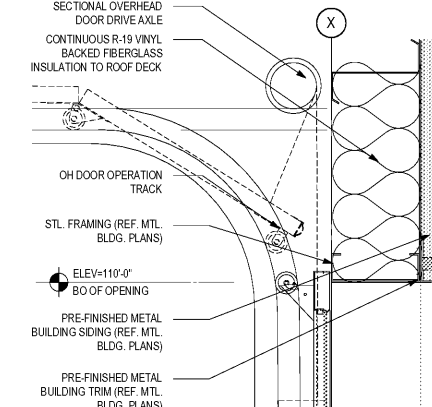

03 PEMB OVERHEAD DR HDR
1-1/2" = 1'-0"

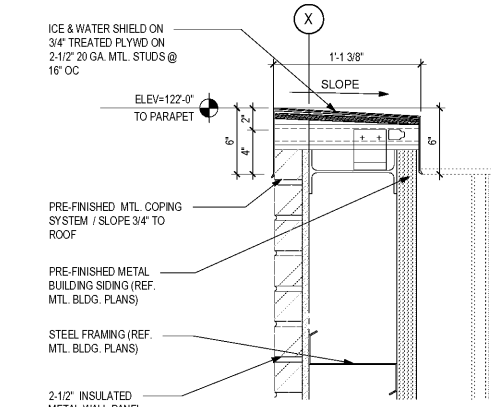

02 LOW PARAPET AT OFFICE
1-1/2" = 1'-0"

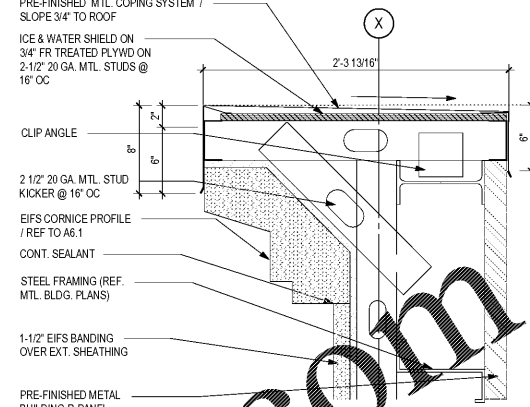

01 HIGH PARAPET AT OFFICE
1-1/2" = 1'-0"

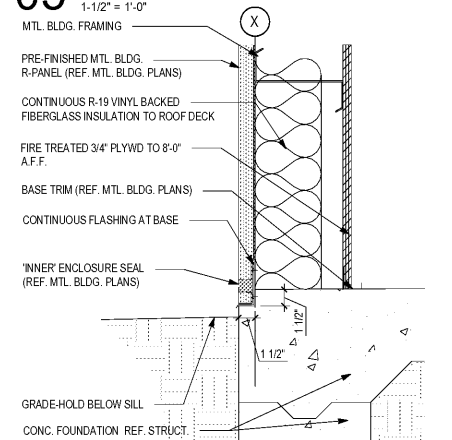

10 PEMB SILL (GRADE COND)
1-1/2" = 1'-0"

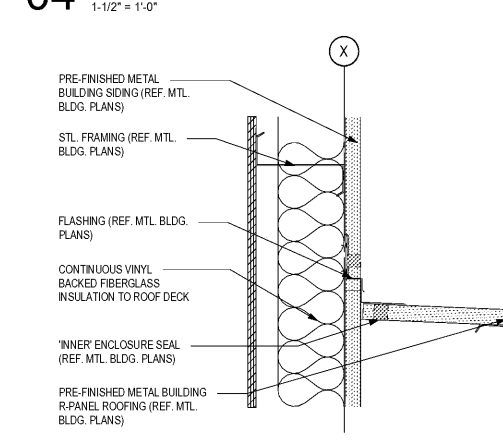

09 PEMB ROOF TO WALL
1-1/2" = 1'-0"

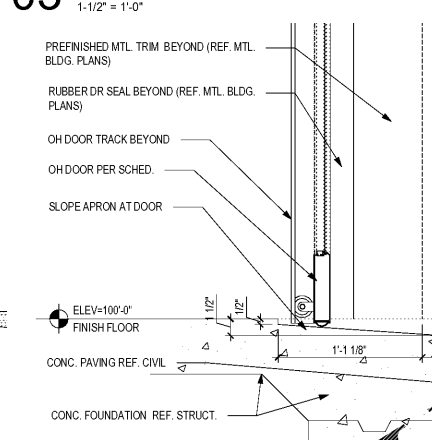

08 PEMB OVERHEAD DR APRON
1-1/2" = 1'-0"

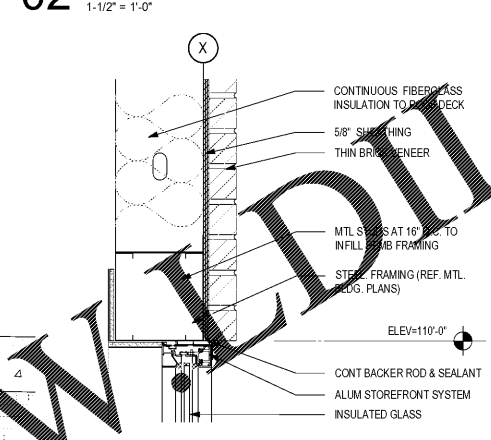

07 WINDOW HDR AT OFFICE
1-1/2" = 1'-0"

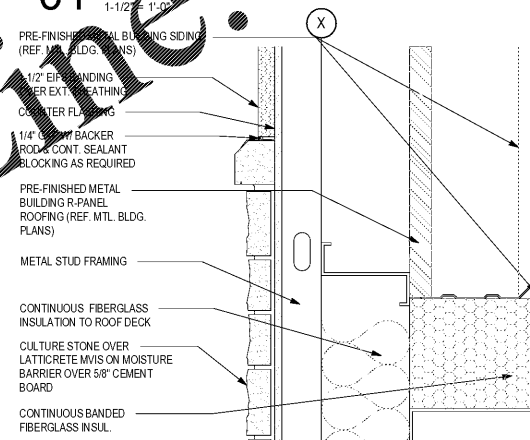

06 ROOF TO WALL DETAIL
1-1/2" = 1'-0"

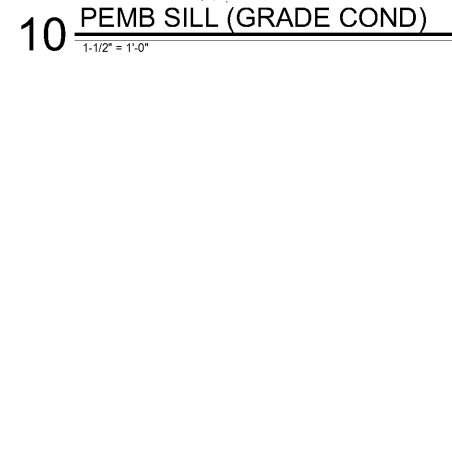

15 NOT USED

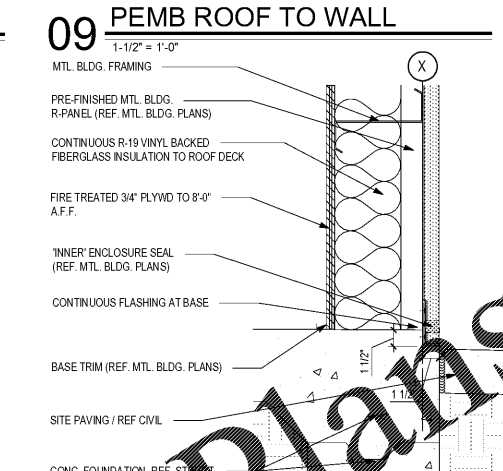

14 PEMB SILL (PAVING COND)
1-1/2" = 1'-0"

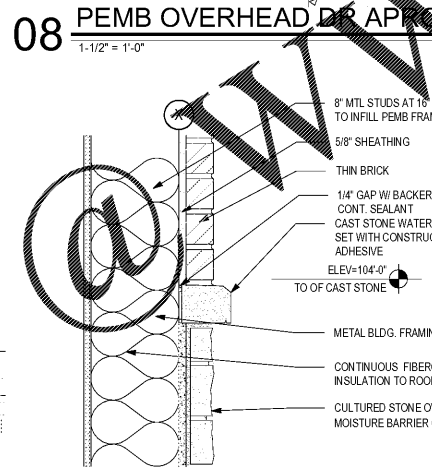

13 WATERTABLE AT OFFICE
1-1/2" = 1'-0"

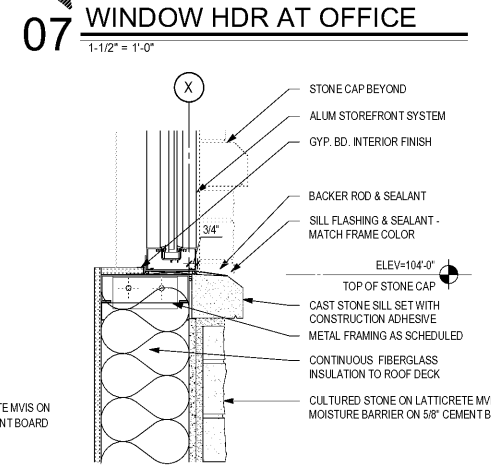

12 WINDOW SILL AT OFFICE
1-1/2" = 1'-0"

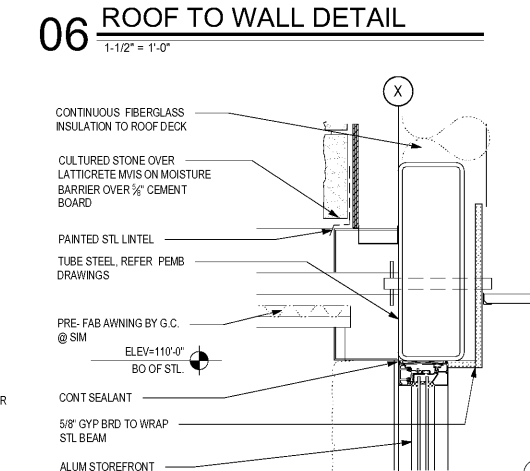

11 WINDOW HDR AT OFFICE
1-1/2" = 1'-0"

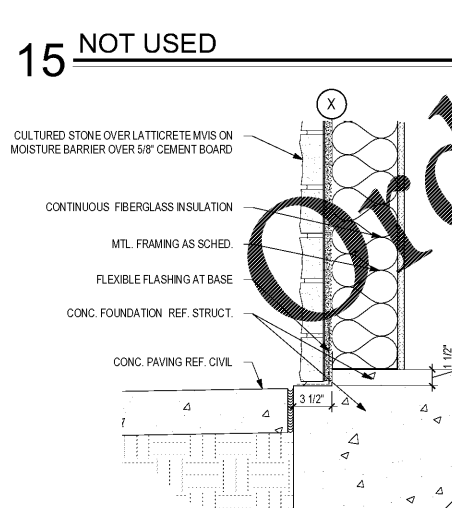

20 BASE DETAIL
1-1/2" = 1'-0"

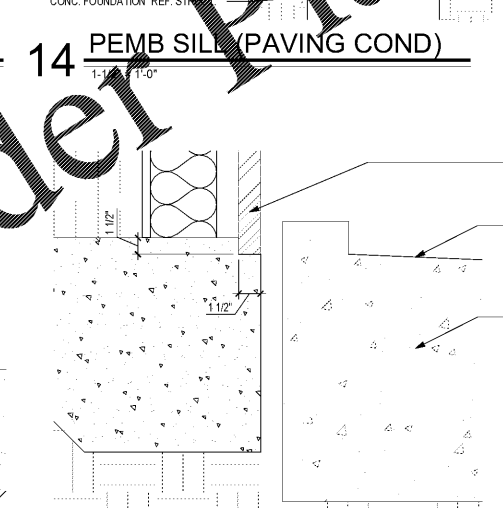

19 BASE DETAIL
1-1/2" = 1'-0"

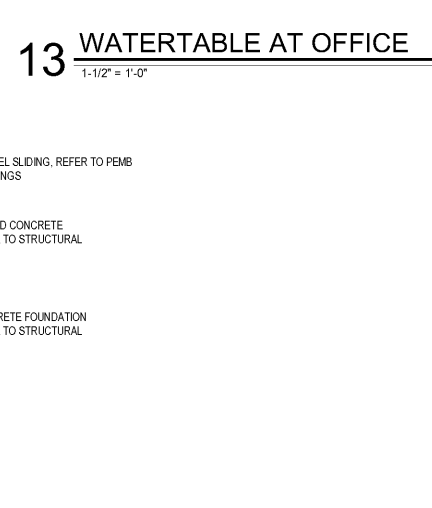

18 NOT USED
NTS

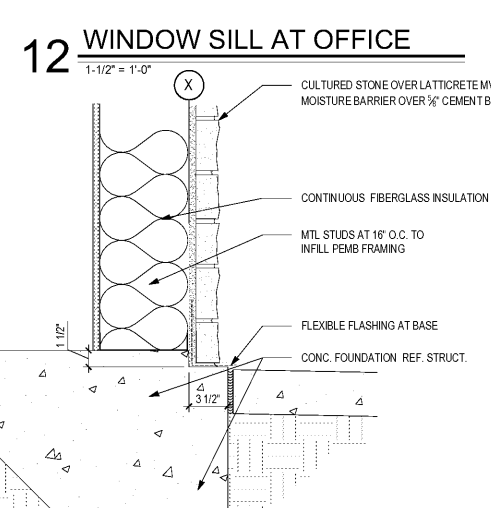

17 BASE DETAIL
1-1/2" = 1'-0"

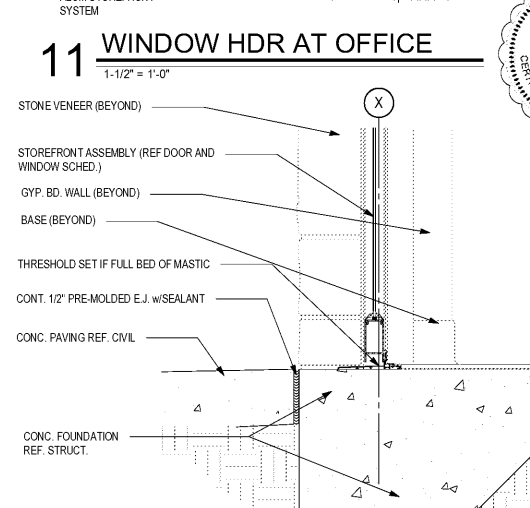

16 BASE DETAIL
1-1/2" = 1'-0"

Order Plans



CLIENT NAME
Cross Development
4536 Marshall Ridge
Carrington, TX 75010

PROJECT NAME
Caliber Collision Five Forks (161)
1215 East Bulfinch Rd
Greenville, SC 29607

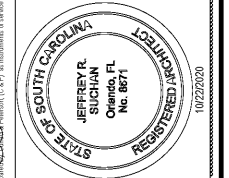

PROJECT NO.	220087
DATE	07/08/2020
DRAWN	JJ
CHECKED	CD

Cheraji & Peterson
Architects Engineers Planners
ORLANDO • PHILADELPHIA

1925 Prospect Av.
Orlando, FL 32814
P (407) 661-9100
F (407) 661-9101
www.cp.com

FLORIDA CORPORATE CERTIFICATE #AA 0006256