

03 GUEST RESTROOMS
1/2"=1'-0"

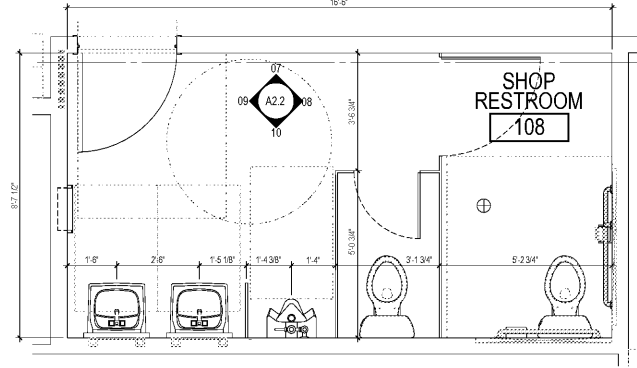

02 ENLARGED RESTROOM PLAN
3/8"=1'-0"

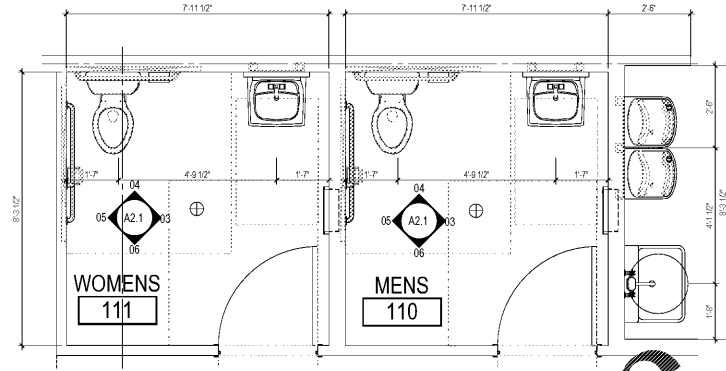

01 ENLARGED RESTROOM PLAN
3/8"=1'-0"

RESTROOM FIXTURE KEY NOTES

- RR 10 RECESSED PAPER TOWEL DISPENSER/ WASTE RECEPTACLES (BOBRICK B-369)
- RR 20 42" GRAB BAR - PROVIDE BLOCKING (BOBRICK B-806 x 42)
- RR 30 36" GRAB BAR - PROVIDE BLOCKING (BOBRICK B-806 x 36)
- RR 40 24" x 36" MIRROR (BOBRICK B-293 2436)
- RR 50 SANITARY NAPKIN DISPOSAL - ONLY AT WOMENS (BOBRICK B-270)
- RR 60 SOAP DISPENSER (BOBRICK B-40)
- RR 70 TOILET SEAT COVER DISPENSER (BOBRICK B-221)
- RR 80 TOILET TISSUE DISPENSER (BOBRICK B-2730)
- RR 90 18" VERTICAL GRAB BAR (WALL MOUNTED) (BOBRICK B-806)
- RR 100 COMBI DOOR KICKER (DELTA - W-5002)

SHEET NOTES

1. REFER SHEET A6.0 FOR FINISH LEGEND.
2. ALL PLUMBING FIXTURES SHOWN ARE SHOWN FOR REPRESENTATION - REFER MEP SHEETS FOR FIXTURE SCHEDULE.
3. PLANS DIMENSIONS ARE TO FACE OF FRAMING UNLESS NOTED OTHERWISE.

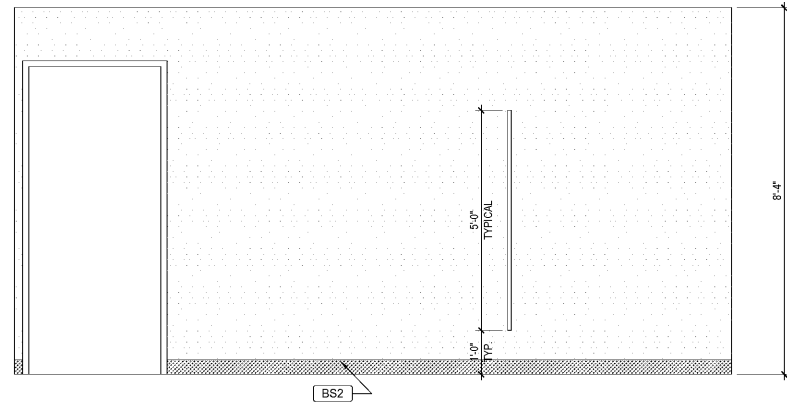

07 SHOP RESTROOM
1/2"=1'-0"

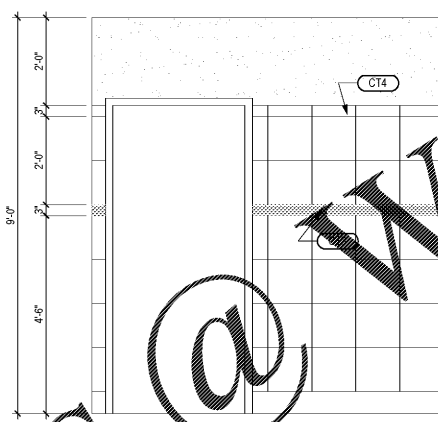

06 GUEST RESTROOMS
1/2"=1'-0"

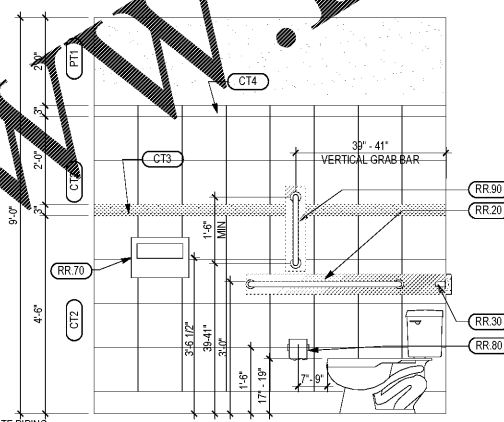

05 GUEST RESTROOMS
1/2"=1'-0"

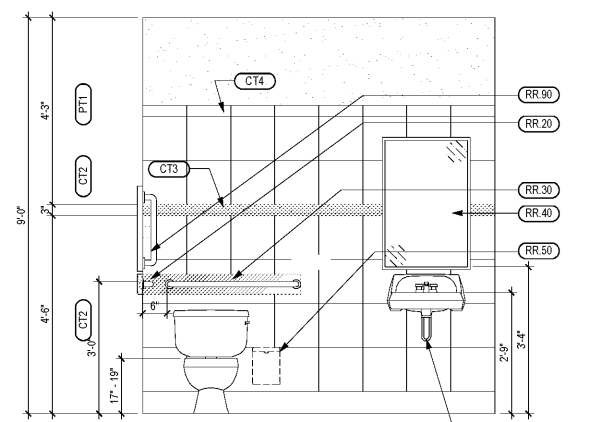

04 GUEST RESTROOMS
1/2"=1'-0"

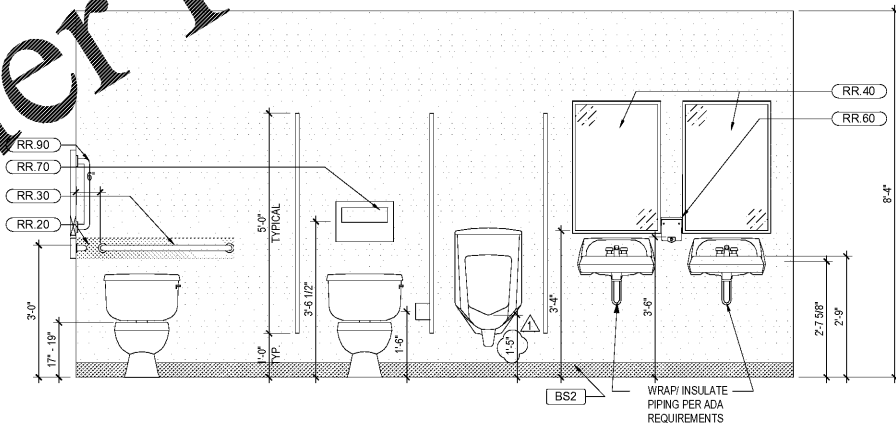

10 SHOP RESTROOM
1/2"=1'-0"

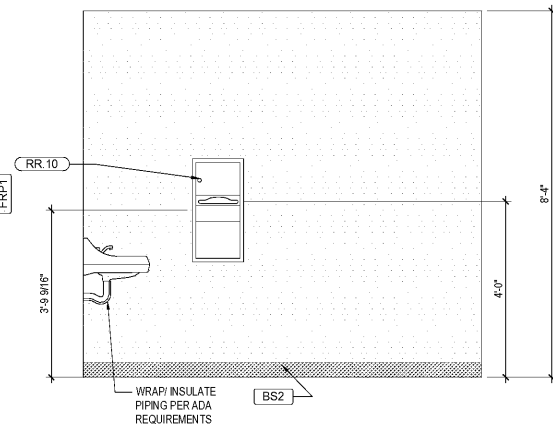

09 SHOP RESTROOM
1/2"=1'-0"

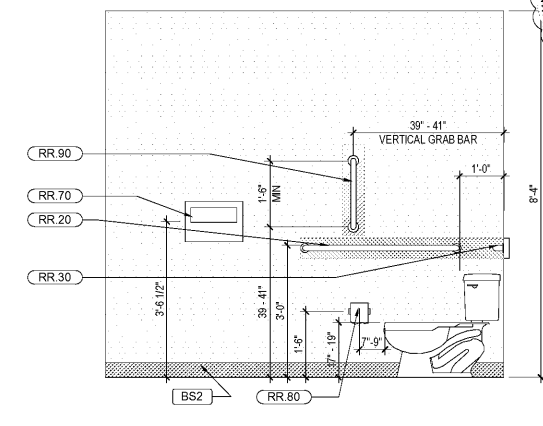

08 SHOP RESTROOM
1/2"=1'-0"

Order Plans @ www.LDILine.com

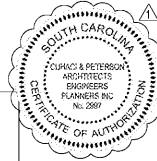

COPYRIGHT © All rights, specifications, computer files, field data, notes and other documents are the property of LDILine.com. No part of this document may be reproduced without the prior written permission of LDILine.com. Any use or reproduction of this document without the prior written permission of LDILine.com is a violation of federal copyright law.

PROJECT NO. 2200857	CLIENT NAME Cross Development	PROJECT NAME Caliber Collision Five Forks (161)	CLIENT ADDRESS 1215 East Buller Rd Greenville, SC 29607
DATE 07/08/2020	PROJECT ADDRESS 1215 East Buller Rd Greenville, SC 29607	PROJECT TITLE Restroom Plans / Elevations	CLIENT ADDRESS 1925 Prospect Av. Orlando, FL 32814 P (407) 661-9100 F (407) 661-9101 www.cp.com Florida Corporate Certificate #AA 0006526
DRAWN JL_JDV	ARCHITECT Culacaj & Peterson Architects Engineers Planners Orlando • Philadelphia	REGISTERED PROFESSIONAL ENGINEER JEFFREY R. SUCHAN No. 8871 STATE OF SOUTH CAROLINA REGISTERED PROFESSIONAL ENGINEER 10/27/2020	
CHECKED CD	PERMIT COMMENTS RESPONSE - 08/22/2020		