

THIS DRAWING IS THE PROPERTY OF MAXDESIGN GROUP AND IS NOT TO BE REPRODUCED IN WHOLE OR IN PART. IT IS NOT TO BE USED ON ANOTHER PROJECT AND SHALL BE RETURNED UPON REQUEST.

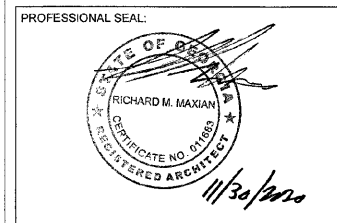

PROJECT TITLE:

**MARKET PLACE
AT LOCUST
GROVE SHOPS
PHASE 2**

LOCUST GROVE, GEORGIA

PROJECT INFO:
4959 BILL GARDNER PARKWAY
LOCUST GROVE, GA 30248

OWNER:

IP ILG, LLC

JACOB LANG
912.655.3438

PRINT RECORD	
Description	Date
ISSUED FOR PERMIT	11.23.2020

REVISION		
No.	Description	Date

**ENLARGED PLAN AND
DUMPSTER DETAILS**

Project number: D20-101
Date: 10/26/2020
Drawn by: B.C.R.
Checked by: R.M.M.

A-401

Scale: As indicated

ISSUED FOR CONSTRUCTION

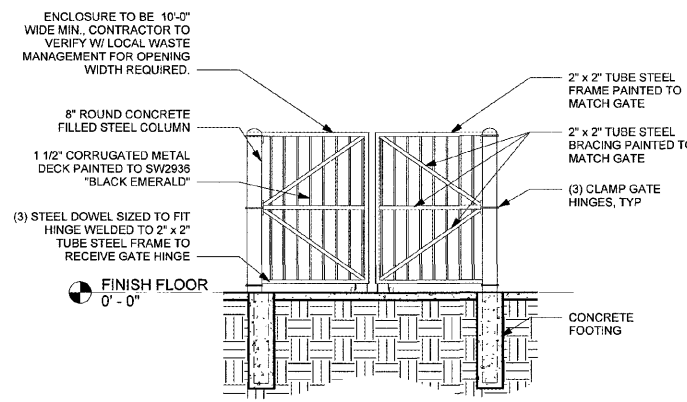

10 DUMPSTER GATE INTERIOR VIEW
A-401 SCALE: 1/4" = 1'-0"

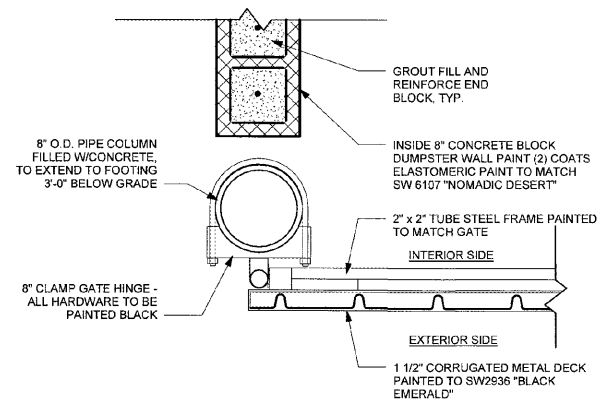

9 DUMPSTER GATE DETAIL
A-401 SCALE: 1 1/2" = 1'-0"

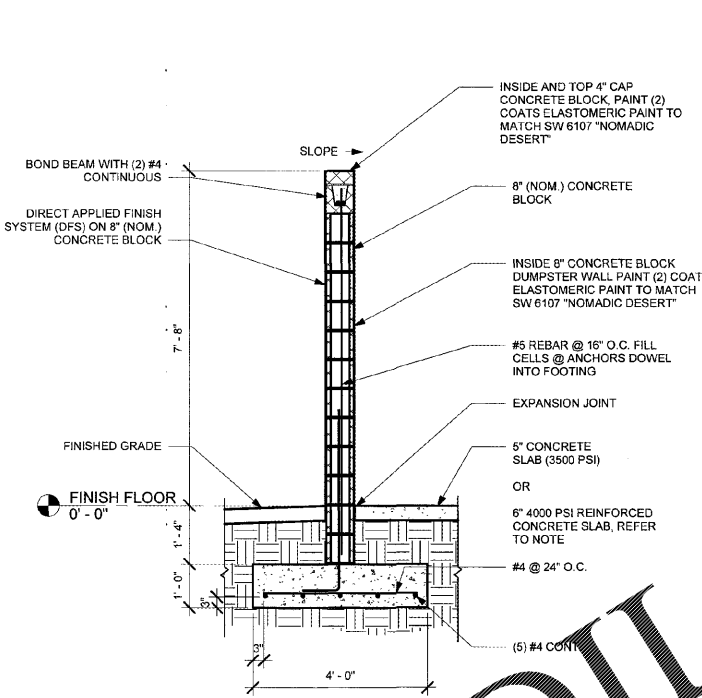

8 SECTION AT DUMPSTER WALL
A-401 SCALE: 1/2" = 1'-0"

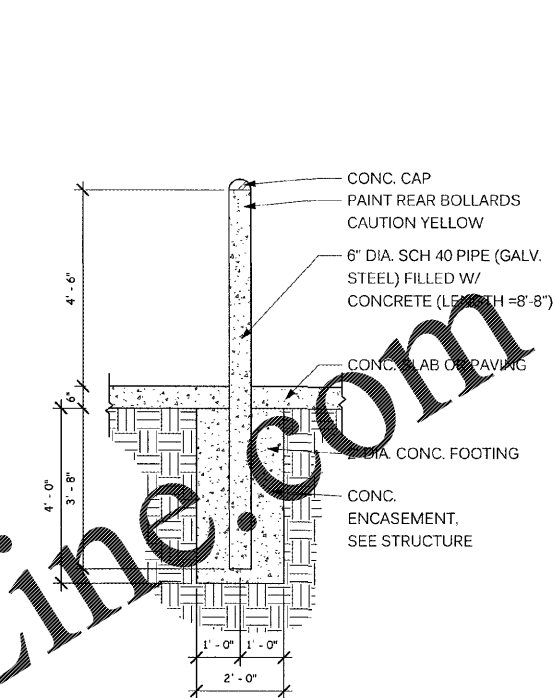

7 DUMPSTER BOLLARD DETAIL
A-401 SCALE: 1/2" = 1'-0"

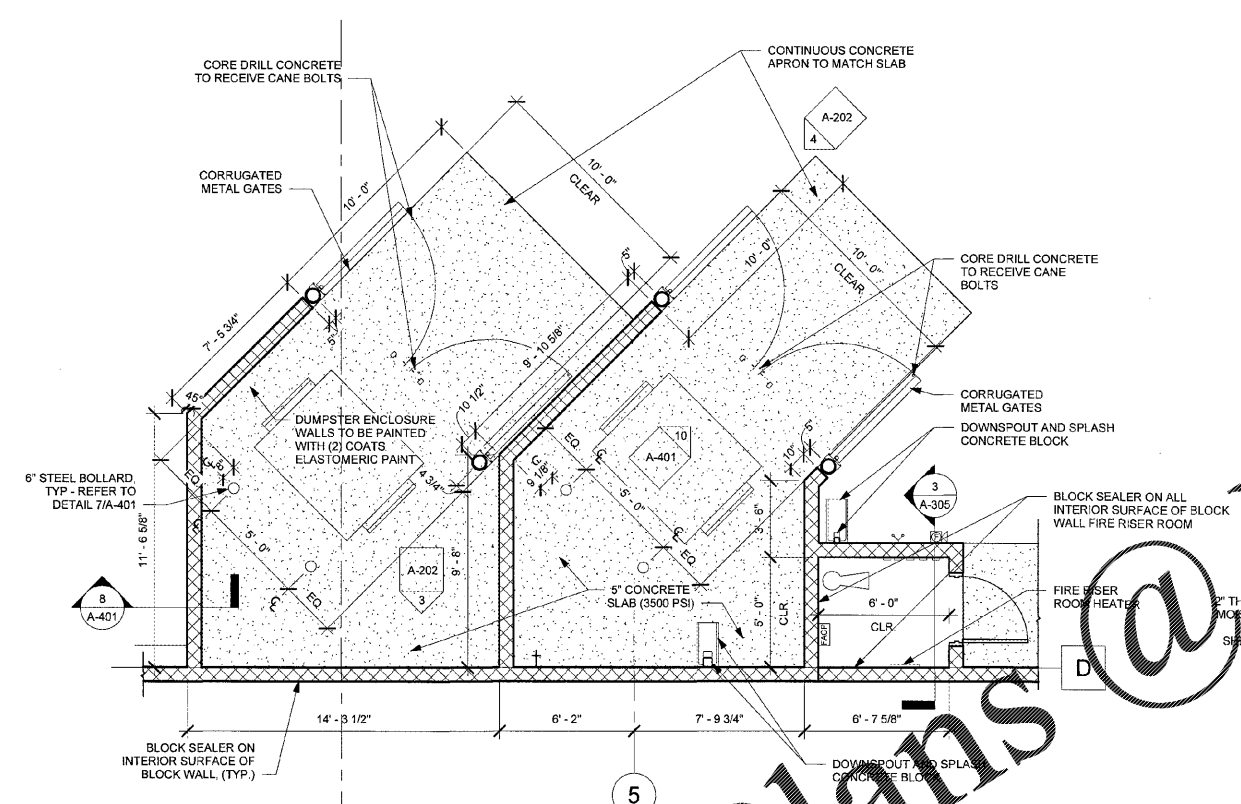

6 DUMPSTER AND FIRE RISER ROOM
A-401 SCALE: 1/4" = 1'-0"

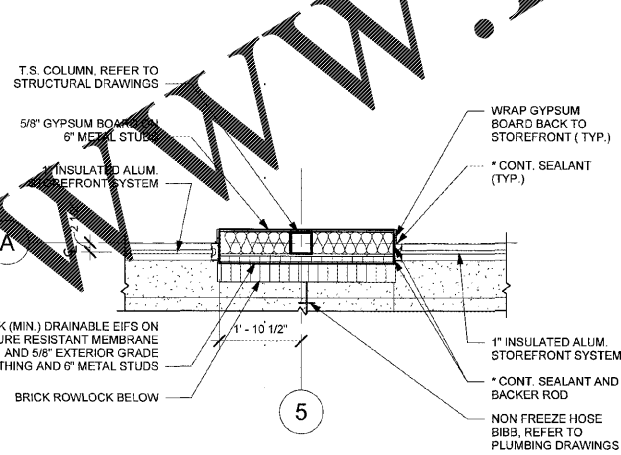

4 LOW ROWLOCK PILASTER DETAIL
A-401 SCALE: 1/2" = 1'-0"

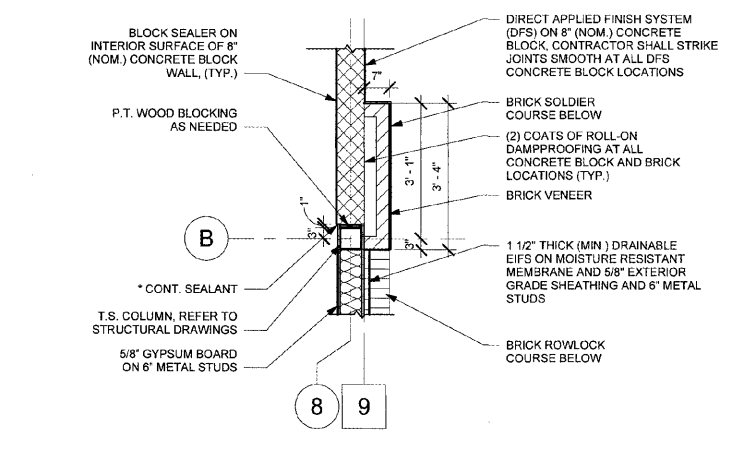

5 PILASTER ON CONCRETE BLOCK DETAIL
A-401 SCALE: 1/2" = 1'-0"

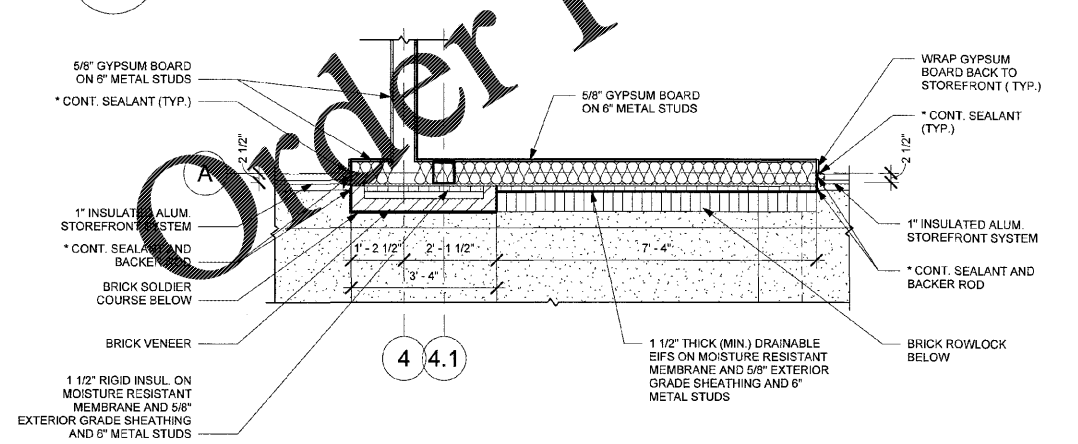

3 PILASTER AT LOW ROWLOCK DETAIL
A-401 SCALE: 1/2" = 1'-0"

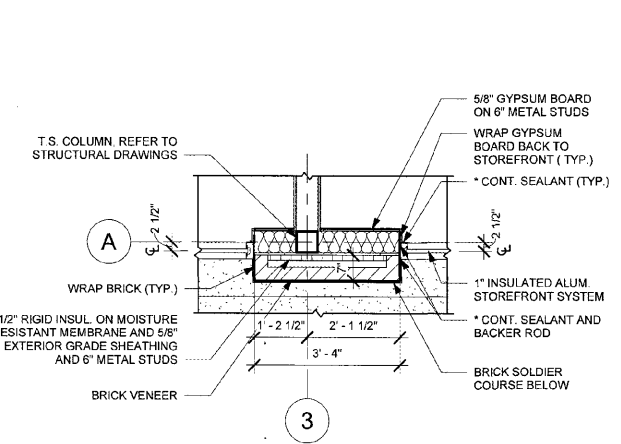

2 FRONT PILASTER DETAIL
A-401 SCALE: 1/2" = 1'-0"

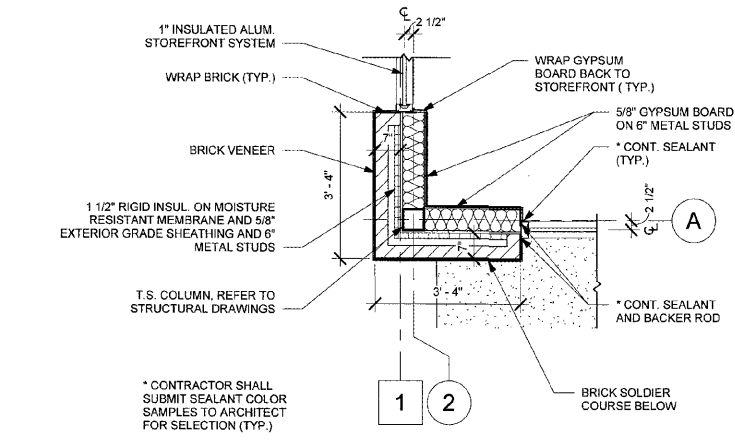

1 CORNER PILASTER DETAIL
A-401 SCALE: 1/2" = 1'-0"

Order Plans @

WWW.LDOnline.com