

PLOT DATE: 12/11/20 2:31 PM
 R:\07-Production\0206124\0206124-ICC-01 - Lake Lanier Islands Conference Center -\Production\Engineering\Design\LI Conference Center\0206124-ICC-PIPE.dwg

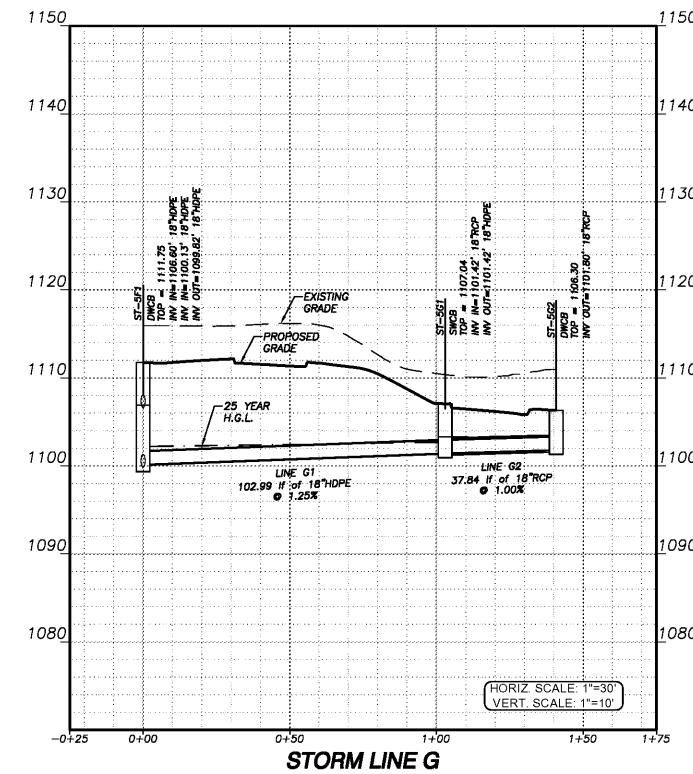

Order Plans

WWW.LDIline.com

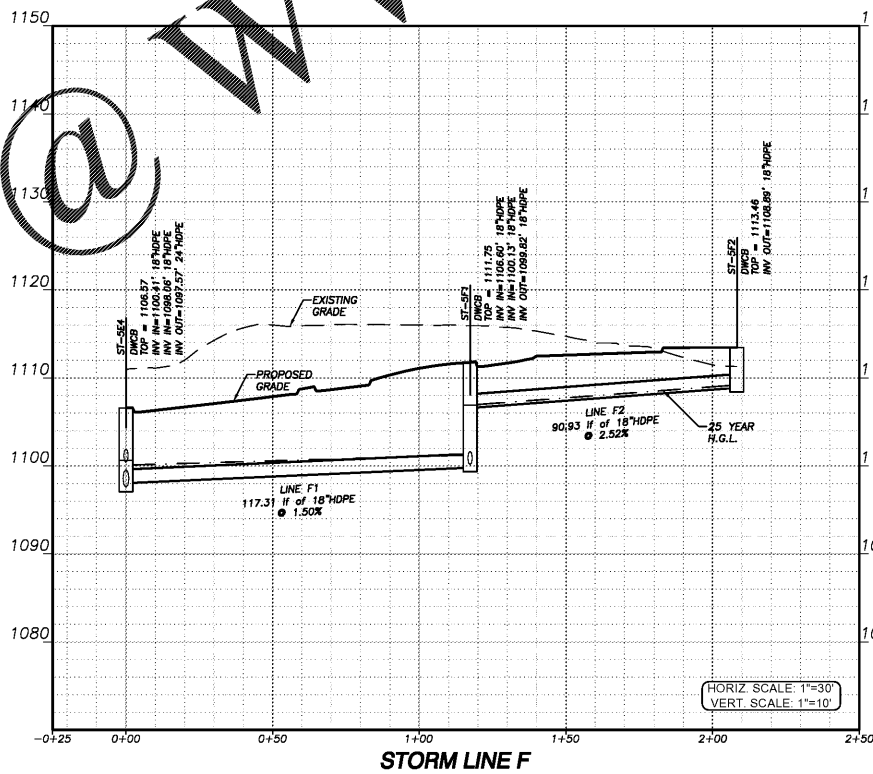
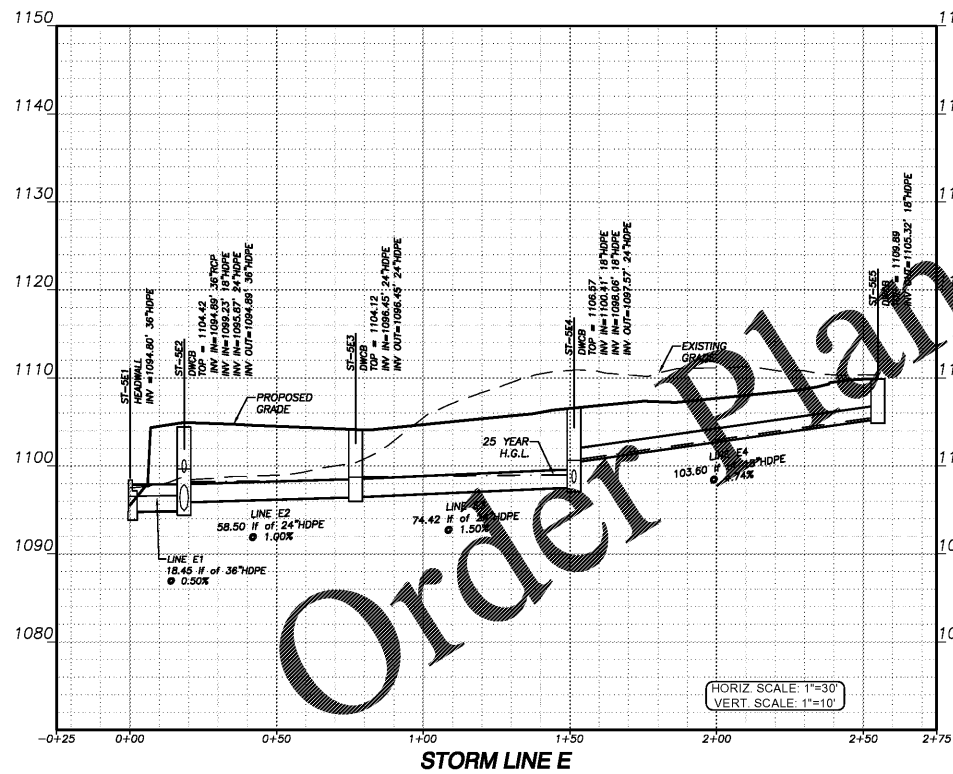
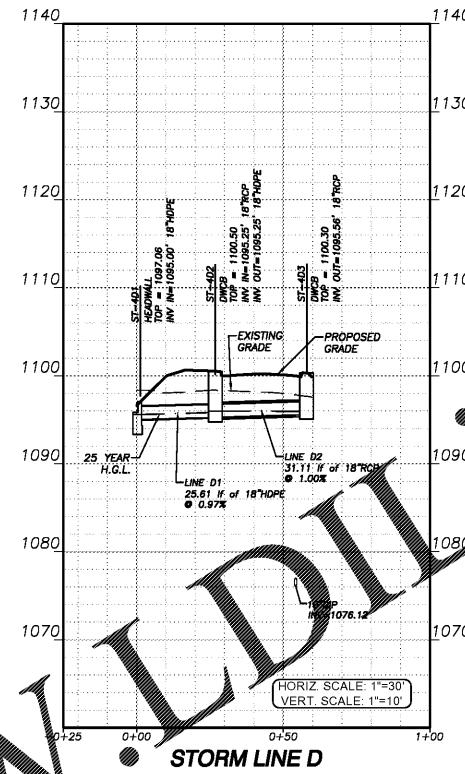
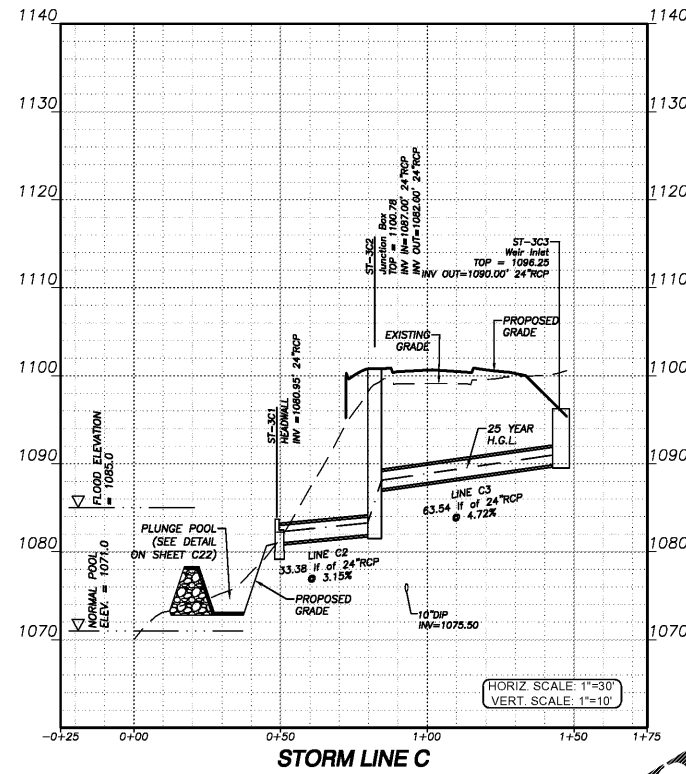
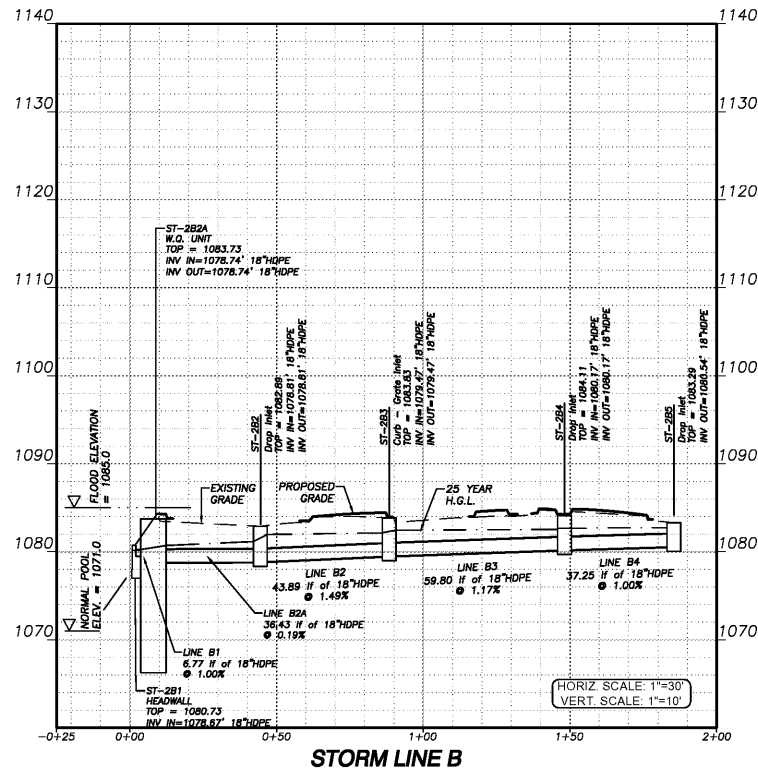

STORM PROFILES
 FOR:
**LANIER ISLANDS
 CONFERENCE CENTER**
 LAND LOT 380
 7TH DISTRICT
 CITY OF BUFORD, HALL COUNTY, GEORGIA

REV	DATE	DESCRIPTION

ANY CHANGES OR ALTERATIONS MADE TO THESE CONSTRUCTION DRAWINGS WITHOUT THE SIGNATURE OF THE PROFESSIONAL ENGINEER AND ANY LIABILITY ASSOCIATED THEREWITH ARE KEPT ON FILE FOR VERIFICATION OF ANY CHANGES.



SHEET
C26
 OF
C66
 DATE: 12-11-20
 SCALE: 0206124/ICC-01
 JOB NO.:
 REV'D BY: JNC
 DRAWN BY: JRS

NOTE:
 SEE SHEET C31 FOR PIPE CHART INFORMATION