



**CRAIG A. SCNEIDER, AIA**  
ARCHITECT

417.862.0658  
417.862.3265  
1736 East Sunshine, Suite 417  
Springfield, Missouri 65804  
e-mail: architect@entertechinc.com

PROJECT:  
**NEW O'REILLY AUTO PARTS STORE**  
CLEVELAND, HIGHWAY  
VARNELL, GA  
**INTERIOR SECTIONS & DETAILS**

**O'Reilly AUTO PARTS**  
CORPORATE OFFICES  
233 SOUTH PATTERSON  
SPRINGFIELD, MISSOURI 65802  
(417) 862-2874 TELEPHONE

COMM # 4420  
DATE: 2-28-2020  
REVISION  
DATE:

A4.2

**GENERAL NOTES**

- (A) REFER TO PROJECT MANUAL FOR ADDITIONAL REQUIREMENTS.
- (B) DIMENSIONS ARE TO ROUGH FACE OF CONCRETE, MASONRY, FRAMING, OR CENTER LINE OF STRUCTURE UNLESS OTHERWISE INDICATED.
- (C) REFER TO INTERIOR FINISH SCHEDULES FOR MATERIAL TYPES, COLORS AND FINISHES.

**KEY NOTES**

- (1) PRE-ENGINEERED METAL BUILDING STRUCTURAL STEEL COLUMN. REFER TO P.E.M.B. SHOP DRAWINGS FOR ADDITIONAL REQUIREMENTS THAT ARE INDICATED.
- (2) 3/8" COLD FORM METAL FRAMING ATTACHED TO ROOF STRUCTURE. REFER TO STRUCTURAL DRAWINGS FOR FRAMING REQUIREMENTS.
- (3) 3/8" (24 GA) COLD FORM METAL FRAMING AT 24" O.C. REFER TO INTERIOR WALL TYPES FOR ADDITIONAL REQUIREMENTS.
- (4) COLD FORM METAL STUDS DOUBLED AT CONTROL JOINT.
- (5) 6" (60S162-54) COLD FORM METAL CEILING JOIST FRAMING AT 24" O.C.
- (6) 5/8" TYPE "X" GYPSUM BOARD. REFER TO INTERIOR WALL TYPES AND FOR ADDITIONAL REQUIREMENTS.
- (7) GYPSUM BOARD CORNER BEAD CONTINUOUS.
- (8) GYPSUM BOARD "J" MOLDING CONTINUOUS.
- (9) GYPSUM BOARD CONTINUOUS EXPANSION JOINT. PROVIDE FRY REGLET "DRMF-625-75" AND "JDM-625" AT JOINT ON BOTH SIDES OF WALL.
- (10) FIRE TREATED 2X NAILERS OR BLOCKING.
- (11) (2) FIRE TREATED 2X NAILERS.
- (12) 1X4 WOOD TRIM (PAINT GRADE PINE) ATTACHED TO METAL STUD FRAMING WITH TECH 12 SCREWS AT 24" O.C. SET FLUSH. PAINT EXPOSED SURFACES TO MATCH WALL FINISH.
- (13) 6" UNFACED SOUND BATT INSULATION.
- (14) 3 1/2" UNFACED SOUND BATT INSULATION.
- (15) ALUMINUM WINDOW SYSTEM. REFER TO FLOOR PLAN AND WINDOW SCHEDULE FOR TYPES.
- (16) PRE-FINISHED SHEET METAL (24 GA) COLUMN ENCLOSURE TO EXTEND THRU FINISH CEILING SYSTEM. COLOR TO MATCH WINDOW FRAMING FINISH. NO EXPOSED HORIZONTAL BEAMS PERMITTED.
- (17) SUSPENDED ACOUSTICAL CEILING SYSTEM. REFER TO INTERIOR FINISH SCHEDULE FOR TYPES AND LOCATIONS.
- (18) FINISH FLOORING AND BASE. REFER TO INTERIOR FINISH SCHEDULE FOR TYPES AND LOCATIONS.
- (19) OWNER FURNISHED AND INSTALLED FIXTURE. REFER TO INTERIOR FINISH PLAN FOR LAYOUT. (REFER TO SCOPE OF WORK SCHEDULE).
- (20) 5/8" FIRE TREATED PLYWOOD BACKING TO BACK SIDE OF STUD INTERIOR FLANGE ON EACH EXPOSED WALL FACE FROM 8'-0" TO 10'-0" A.F.F. FOR INSTALLATION OF SECURITY MIRRORS (OWNER FURNISHED AND INSTALLED).
- (21) PORTABLE FIRE EXTINGUISHER MOUNTED AT 27" ABOVE FINISH FLOOR TO BOTTOM OF EXTINGUISHER. FIRE EXTINGUISHERS SHALL BE UL LISTED ABC TYPE, WITH 10 LBS. CAPACITY MOUNTING BRACKET QUICK RELEASE TYPE. REFER TO FLOOR PLAN FOR LOCATIONS. PROVIDE BLOCKING AS REQUIRED FOR MOUNTING.
- (22) TACTILE EXIT SIGN AT EXIT DISCHARGE DOOR STATING "EXIT" WITH CONTRACTED (GRADE 2) BRAILLE. SIGN CONSTRUCTION AND LOCATION TO COMPLY WITH ACCESSIBILITY CODE. MOUNT 48" MINIMUM ABOVE FINISH FLOOR TO BOTTOM OF LOWEST TACTILE CHARACTER AND 60" MAXIMUM ABOVE FINISH FLOOR TO BOTTOM OF HIGHEST TACTILE CHARACTER. REFER TO FLOOR PLAN FOR ADDITIONAL REQUIREMENTS.

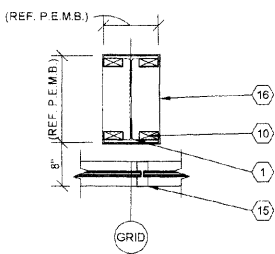

**1 COLUMN DETAIL**  
A4.2 SCALE: 3/4" = 1'-0"

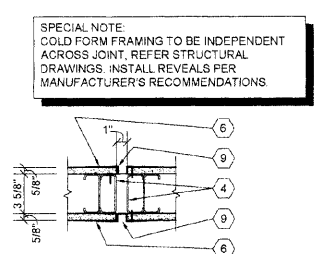

**2 GYPSUM BOARD C.J. DETAIL**  
A4.2 SCALE: 1 1/2" = 1'-0"

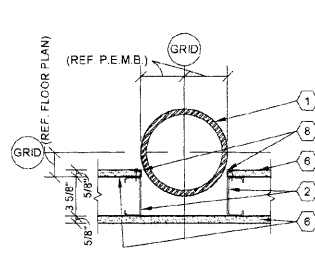

**3 COLUMN DETAIL**  
A4.2 SCALE: 1 1/2" = 1'-0"

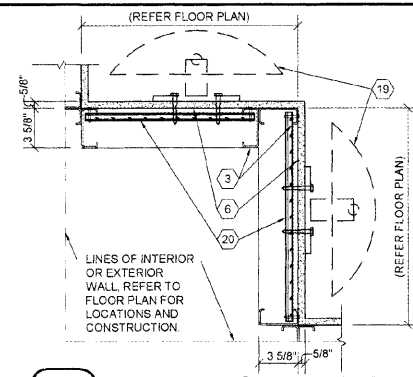

**4 FRAMING DETAIL**  
A4.2 SCALE: 1 1/2" = 1'-0"

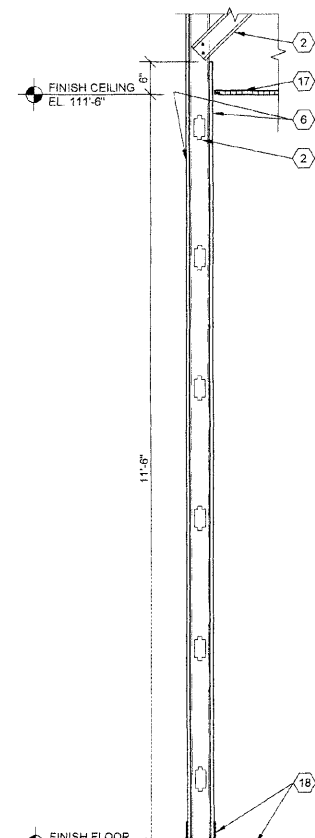

**5 INTERIOR WALL SECTION**  
A4.2 SCALE: 3/4" = 1'-0"

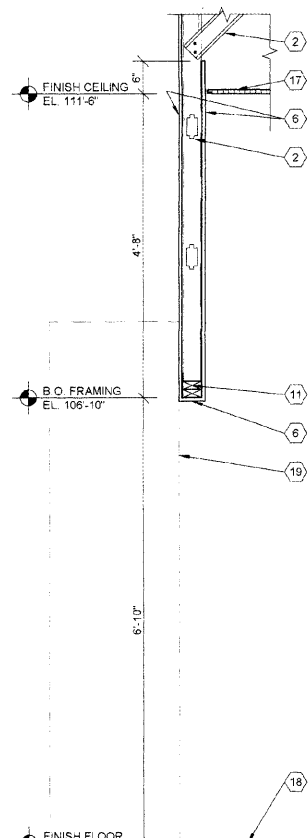

**6 INTERIOR WALL SECTION**  
A4.2 SCALE: 3/4" = 1'-0"

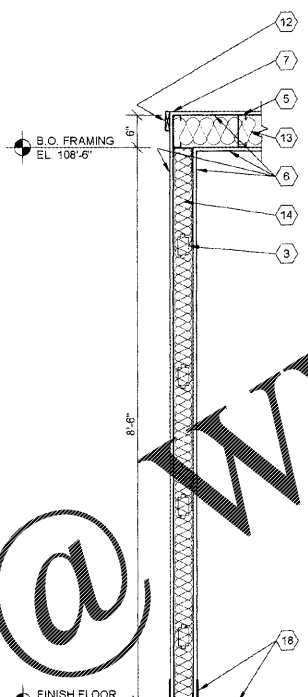

**7 INTERIOR WALL SECTION**  
A4.2 SCALE: 3/4" = 1'-0"

**8 NOT USED**  
A4.2 SCALE: NTS

Order Plans @ [www.LDILine.com](http://www.LDILine.com)

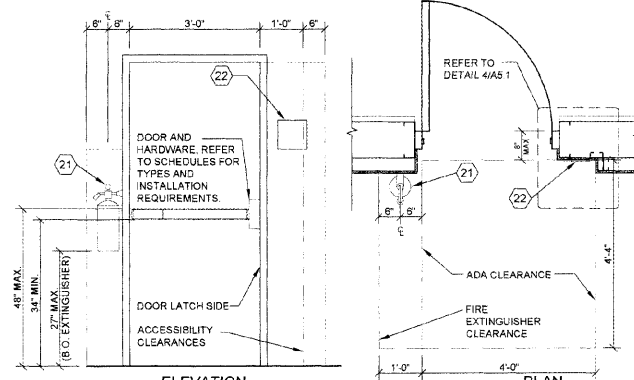

**10 FIRE EXTINGUISHER DETAIL**  
A4.2 SCALE: 1/2" = 1'-0"

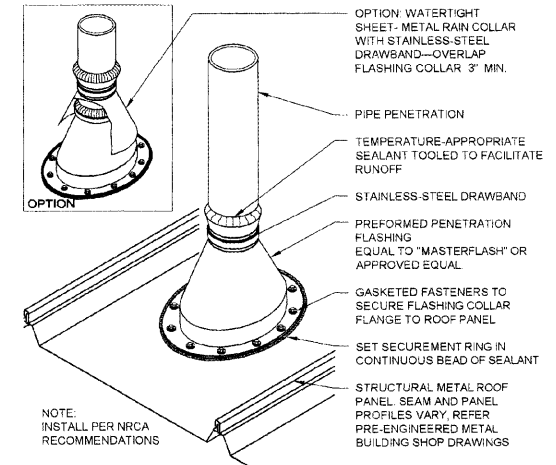

**11 VENT THRU ROOF DETAIL**  
A4.2 NOT TO SCALE

**9 NOT USED**  
A4.2 NOT TO SCALE