

Order Plans @

WWW.IDLine.com

**SITE ELECTRICAL PLAN NOTES**

1. DEMO EXISTING TENNIS COURT LIGHTING.
2. PROVIDE NEW SPORTS LIGHTING SYSTEM AT TENNIS COURTS. CONTACT ROB STAPLES AT MUSCO FOR PRICING AND MORE INFORMATION. Rob.Staples@musco.com 706.482.0175

**ELECTRICAL PLAN KEYNOTES**

VALUE	NOTE
T1	MOUNT AT 1'-0" ABOVE PLAYING SURFACE AT FENCE.

**TENNIS**

LOCATION: Uliby, 126 V/206 V. Three PHASES: 3 A.I.C. RATING: 10000  
 SUPPLY FROM: Utility, 120 V/206 V. Three PHASES: 3 MAINS TYPE: MCB  
 MOUNTING: Surface WIRES: 4 MAINS RATING: 125 A  
 ENCLOSURE: Type 1 FEED-THRU LUGS: No BUS RATING: 125 A

#	CIRCUIT DESCRIPTION	TRIP	POLES	A	B	C	POLES	TRIP	CIRCUIT DESCRIPTION	#
1	REGS	20 A	1	300	870		2	20 A	POLE T1	1
3	REGS	20 A	1							4
5	REGS	20 A	1			380	1740	2	A	5
7	SPARE	20 A	1	0	1740				LIGHTS - POLE T2	6
9	SPARE	20 A	1	0	870					10
11	SPARE	20 A	1	0	870			2	LIGHTS - POLE T3	12
13	SPARE	20 A	1	0	870					14
15	SPARE	20 A	1	0	870				LIGHTS - POLE T4	16
17	SPARE	20 A	1	0	1740					18
19	SPACE ONLY			0	1740				LIGHTS - POLE T5	20
21	SPACE ONLY			0	870			1	20 A	22
23	SPACE ONLY			0	870				LIGHTS - POLE T6	24
25	SPACE ONLY			0	0				SPACE ONLY	26
27	SPACE ONLY			0	0				SPACE ONLY	28
29	SPACE ONLY			0	0				SPACE ONLY	30
TOTAL CONNECTED LOAD:		1100 VA		3840 VA						
TOTAL CONNECTED AMPS:		32 A		4 A						

LOAD CLASSIFICATION	CONNECTED LOAD	DEMAND FACTOR	ESTIM. DEMAND	PANEL TOTALS
Receptacle	1080 VA	100.00%	1080 VA	TOTAL CONNECTED LOAD: 11000 VA
Lighting	18920 VA	125.00%	17400 VA	TOTAL ESTIMATED DEMAND: 18480 VA
				TOTAL CONNECTED AMPS: 127 A
				CALCULATED DEMAND AMPS: 51 A

NOTES:  
 1. PANELBOARD SHALL BE SERVICED IN NEMA 3R HOUSING.  
 2. SERVICE ENTRANCE CABLE SHALL BE 3/4" Ø, 90°C.  
 3. PROVIDE SERVICE ENTRANCE GROUND FLEXIBLE.

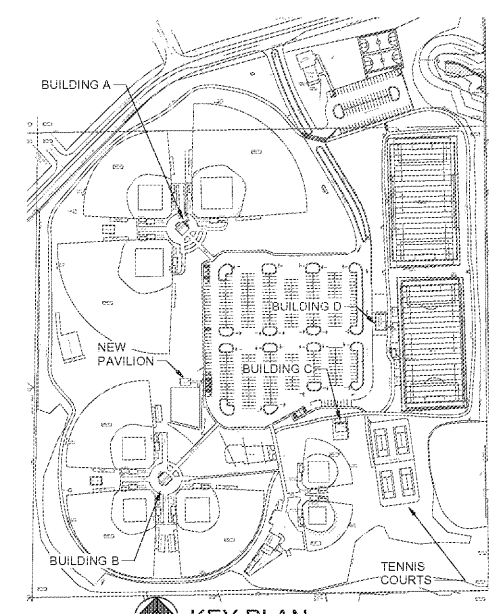
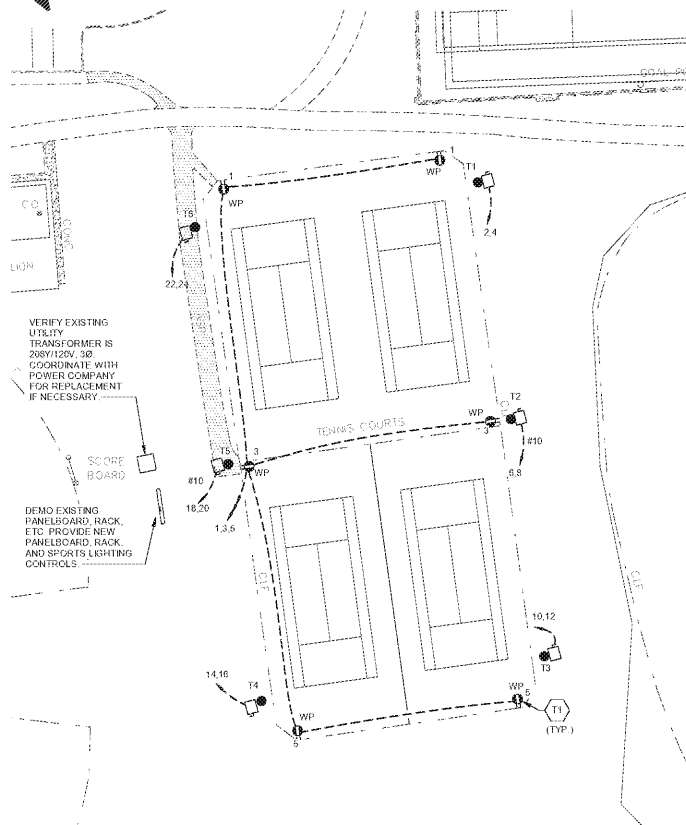
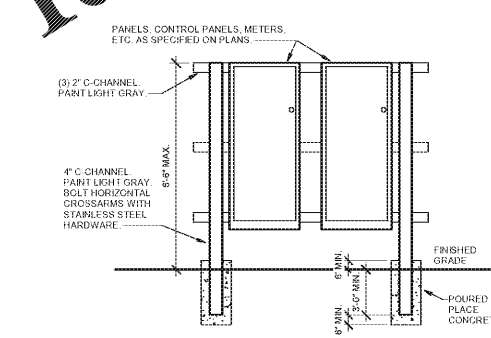
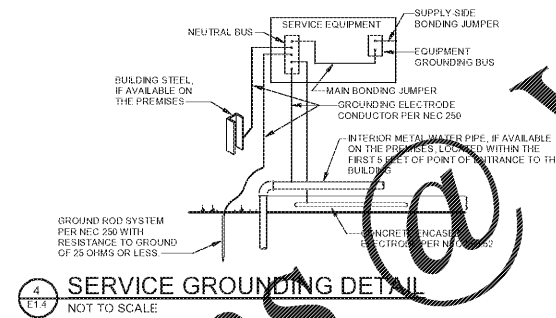

**ROBERTSON LOIA ROOF**  
 ARCHITECTS & ENGINEERS  
 4460 Preston Ridge Road - Suite 277 - Alpharetta, GA, 30015  
 770-874-2600 / www.rlrpc.com  
 GA CO# PE000892 EXP#06960202



Sawnee Mountain Park Renovations  
 3995 WATSON ROAD  
 CUMMING, GA 30028  
 FOR: Forsyth Co. Parks & Rec. Dept.  
 P.O. BOX 2417  
 CUMMING, GA 30028

REVISIONS

NO.	DESCRIPTION

**ELECTRICAL PLAN - TENNIS COURTS**

SHEET TITLE: ELECTRICAL PLAN - TENNIS COURTS

DATE: 08/04/2020

PROJECT NUMBER: 19323

SHEET NUMBER: E1.4