

Order Plans @ [www.LDILine.com](http://www.LDILine.com)

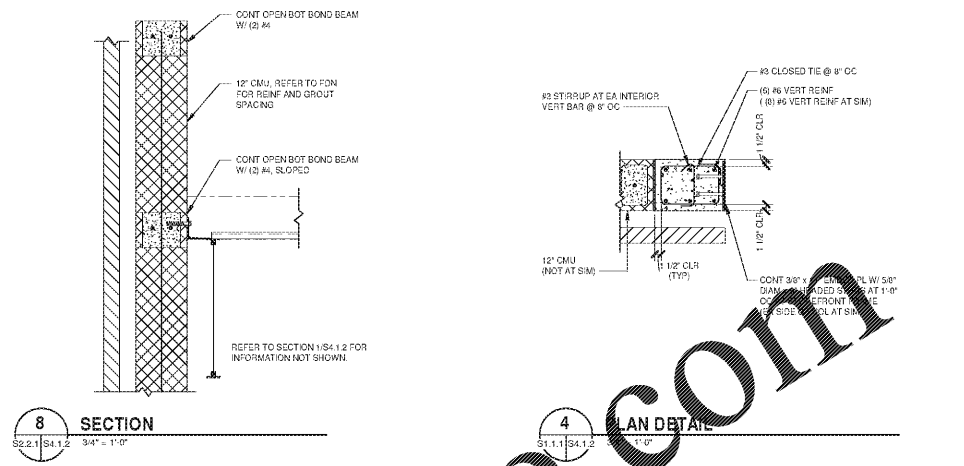

8 SECTION  
S2.2.1/S4.1.2 3/4\"/>

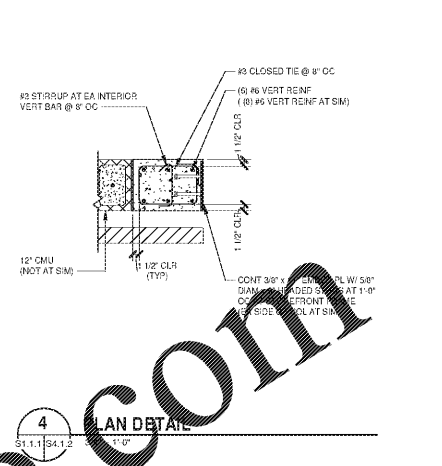

4 PLAN DETAIL  
S1.1.1/S4.1.2 1\"/>

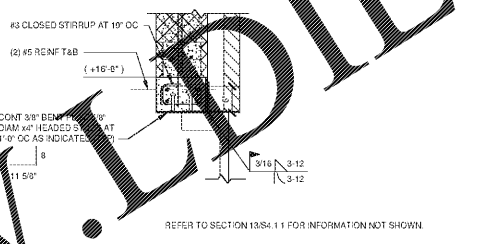

7 SECTION  
S2.2.1/S4.1.2 3/4\"/>

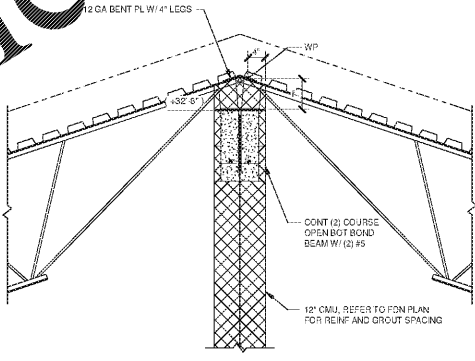

3 SECTION  
S2.2.1/S4.1.2 3/4\"/>

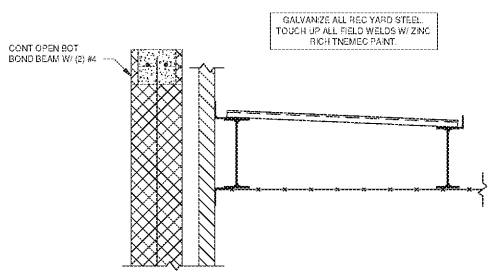

6 SECTION  
S2.2.1/S4.1.2 3/4\"/>

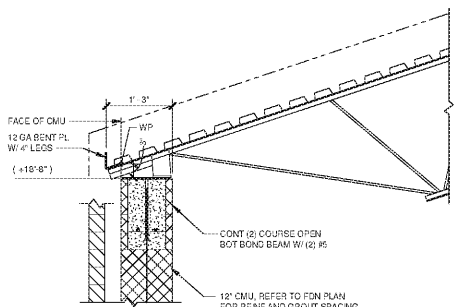

2 SECTION  
S2.2.1/S4.1.2 3/4\"/>

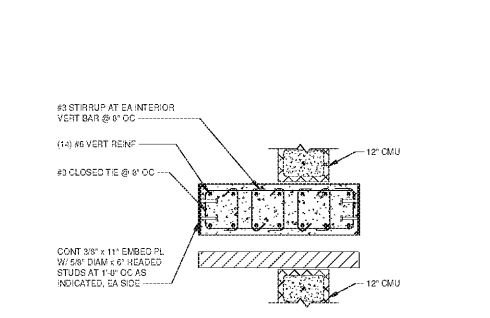

5 PLAN DETAIL  
S1.1.1/S4.1.2 3/4\"/>

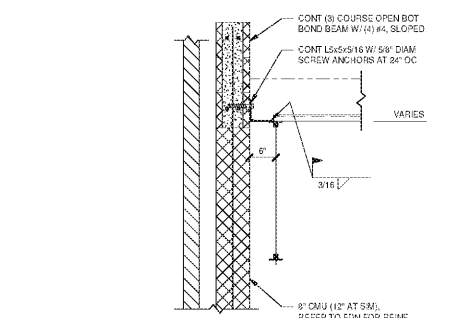

1 SECTION  
S2.2.1/S4.1.2 3/4\"/>

**MOSELEY ARCHITECTS**  
6210 ARDREY KELL ROAD - THE HUB AT WAVERLY, SUITE 405 - CHARLOTTE, NC 28277  
PHONE (704) 540-3755 FAX (704) 540-3754  
MOSELEYARCHITECTS.COM



**MARION COUNTY LEC**  
591492  
MARION COUNTY  
2715 EAST HWY 76, MULLINS, SC 29574

REVISIONS	
DATE	DESCRIPTION
PROJECT NO: 591492	DATE: OCTOBER 30, 2020

FRAMING SECTIONS

S4.1.2

10/30/2020 4:10:55 PM