

Order Plans @ WWW.LDLine.com

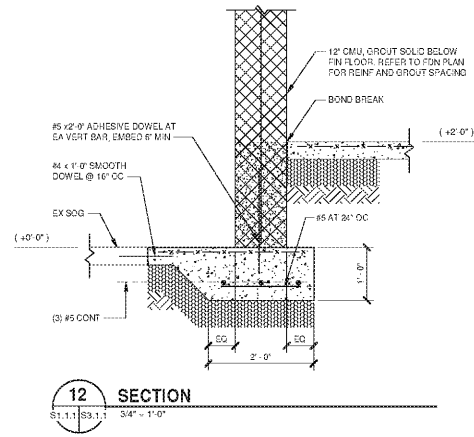

12 SECTION
S1.1.1/S3.1.1 3/4\"/>

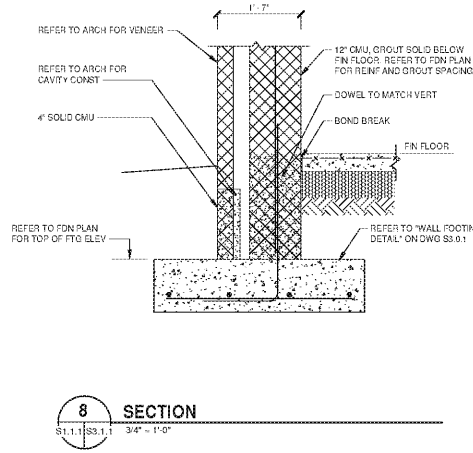

8 SECTION
S1.1.1/S3.1.1 3/4\"/>

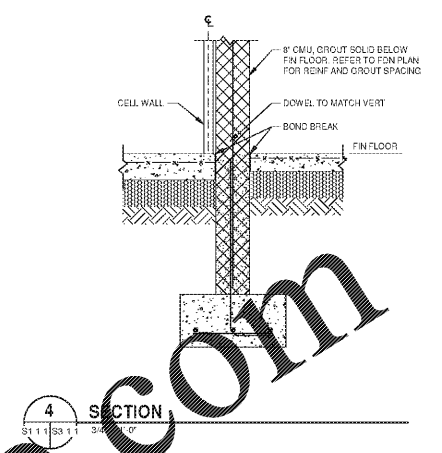

4 SECTION
S1.1.1/S3.1.1 3/4\"/>

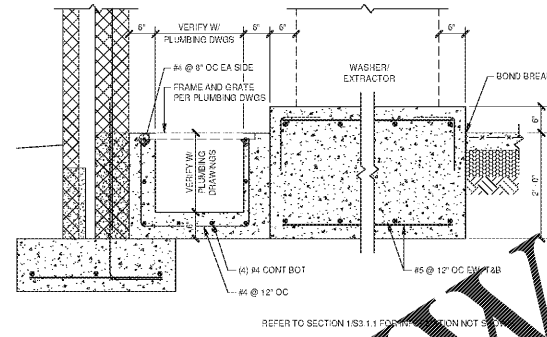

11 SECTION
S1.1.1/S3.1.1 3/4\"/>

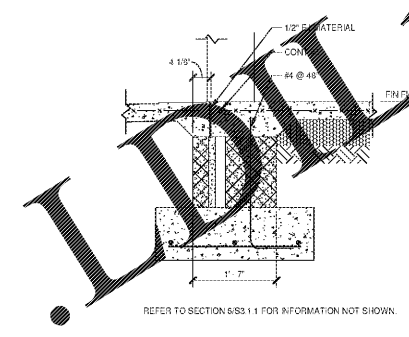

7 SECTION
S1.1.1/S3.1.1 3/4\"/>

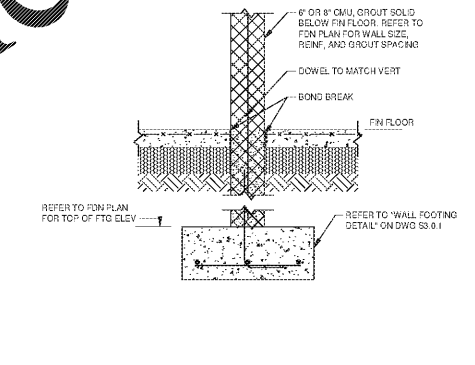

3 SECTION
S1.1.1/S3.1.1 3/4\"/>

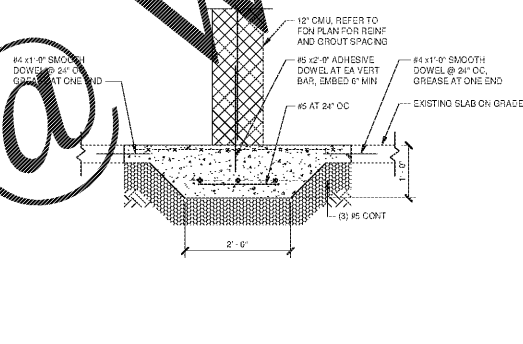

10 SECTION
S1.1.1/S3.1.1 3/4\"/>

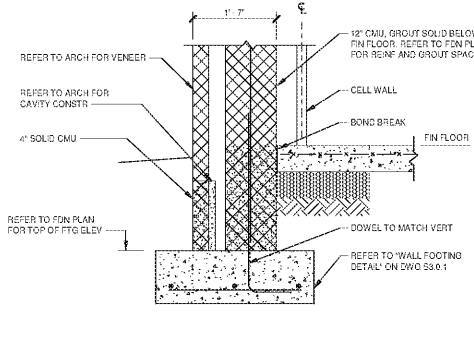

6 SECTION
S1.1.1/S3.1.1 3/4\"/>

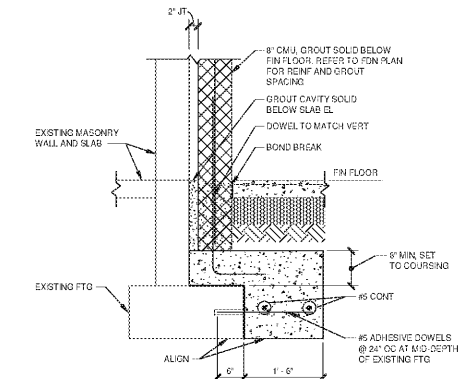

2 SECTION
S1.1.1/S3.1.1 3/4\"/>

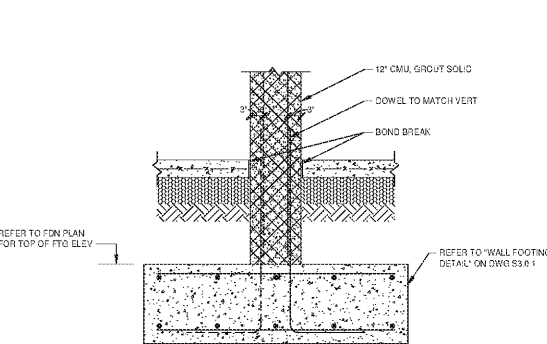

9 SECTION
S1.1.1/S3.1.1 3/4\"/>

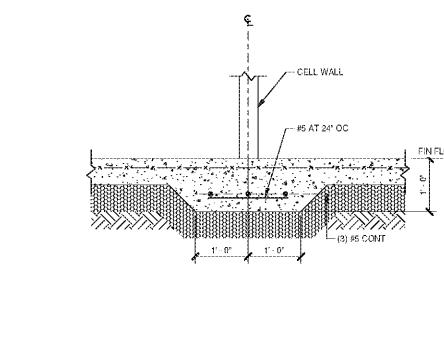

5 SECTION
S1.1.1/S3.1.1 3/4\"/>

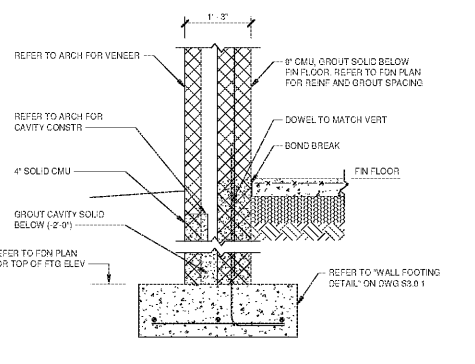

1 SECTION
S1.1.1/S3.1.1 3/4\"/>

MOSELEYARCHITECTS



6210 ARDREY HELL ROAD - THE HUB AT WAVERLY, SUITE 405 - CHARLOTTE, NC 28277
PHONE (704) 540-3755 FAX (704) 540-3754
MOSELEYARCHITECTS.COM

MARION COUNTY LEC

591492
MARION COUNTY
2715 EAST HWY 76, MULLINS, SC 29574

REVISIONS	
DATE	DESCRIPTION
591492	OCTOBER 30, 2020

FOUNDATION SECTIONS

S3.1.1

10/30/2020 4:10:44 PM