

**SLAB-ON-GRADE JOINT LAYOUT GUIDELINES**

- NO SCALE
- NOTES:
1. PROVIDE CONTROL JOINTS IN SLABS ON GRADE WITHIN THE BUILDING SUCH THAT THE AREA BOUNDED BY CONTROL JOINTS DOES NOT EXCEED 225 SQUARE FEET AND JOINT SPACING DOES NOT EXCEED 15'-0" ON CENTER IN ANY ONE DIRECTION.
  2. THE RATIO OF LENGTH TO WIDTH OF THE AREA BOUNDED BY CONTROL JOINTS SHALL NOT EXCEED 1.5 TO 1.
  3. LOCATE CONSTRUCTION JOINTS AND OR CONTROL JOINTS AT COLUMN CENTERLINES.
  4. LOCATE CONSTRUCTION JOINTS AND OR CONTROL JOINTS AT RE-ENTRANT CORNERS.
  5. LOCATE CONSTRUCTION JOINTS PER "PLAN DETAIL AT INTERIOR DOORS".
  6. PROVIDE DIAMOND OR CIRCULAR BLOCKOUTS AT COLUMN.
  7. REINFORCE ALL RE-ENTRANT CORNERS OF SLAB PER "SLAB REINFORCING AT RE-ENTRANT CORNERS".
  8. PROVIDE BOND BREAK WHERE FLOOR ABUTS CMU OR CONCRETE WALL UNLESS NOTED OTHERWISE.
  9. CONTROL JOINT NOT REQUIRED IF DIMENSION AT RE-ENTRANT CORNER IS 2'-0" OR LESS. PROVIDE REINFORCING PER "SLAB REINFORCING AT RE-ENTRANT CORNER".
  10. CONTROL JOINT / CONSTRUCTION JOINT PLANS SHALL BE SUBMITTED IF NOT SHOWN ON FOUNDATION PLANS.

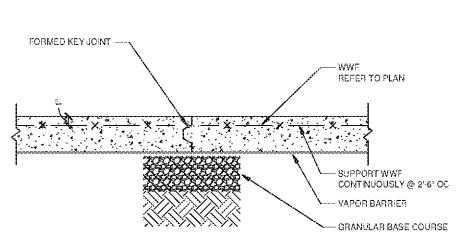

**CONSTRUCTION JOINT**

**SLAB-ON-GRADE JOINT DETAILS**

NO SCALE

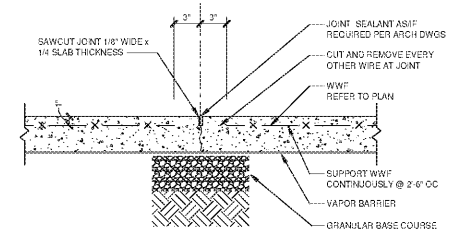

**CONTROL JOINT**

- NOTES:
1. SAWCUT AS SOON AS CONCRETE WILL SUPPORT EQUIPMENT AND EARLY ENOUGH TO PREVENT CRACKING. DO NOT DISLOCATE AGGREGATE.
  2. CONSTRUCTION JOINT MAY REPLACE CONTROL JOINT.

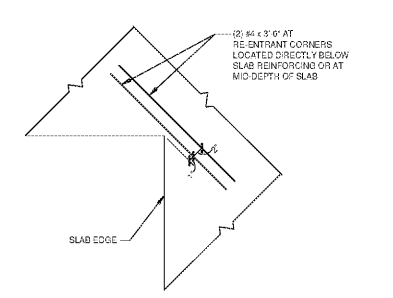

**SLAB REINFORCING AT RE-ENTRANT CORNER**

NO SCALE

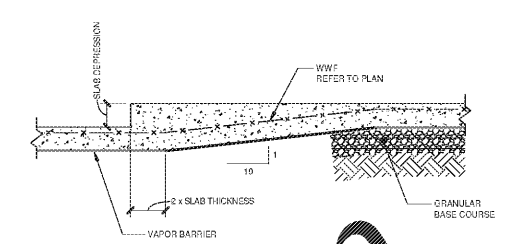

**DETAIL AT SLAB DEPRESSION**

NO SCALE

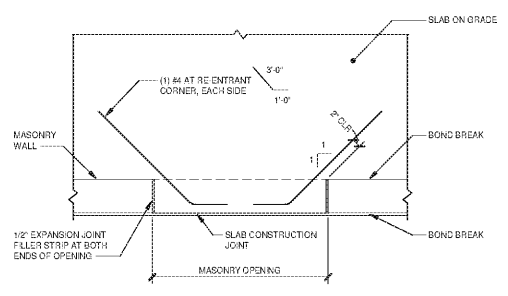

**PLAN AT INTERIOR DOORS**

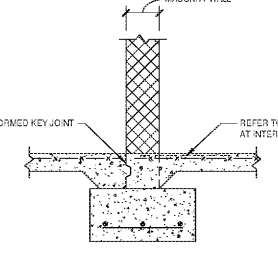

**SECTION AT INTERIOR DOORS**

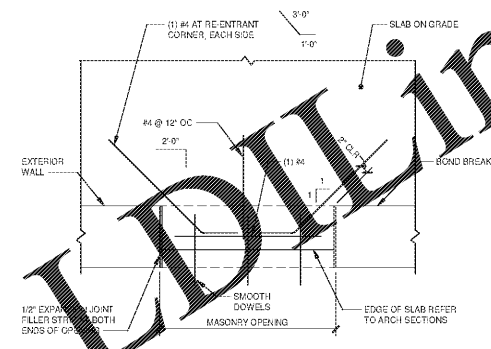

**PLAN AT EXTERIOR DOORS**

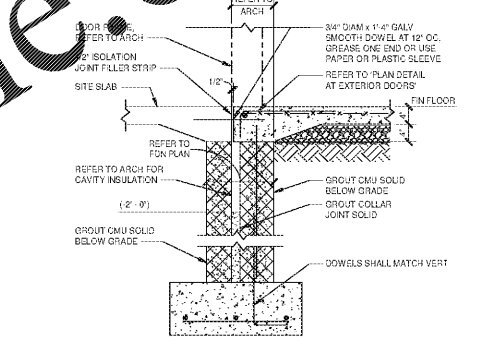

**SECTION AT EXTERIOR DOORS**

**SLAB ON GRADE DETAILS AT DOORS**

NO SCALE

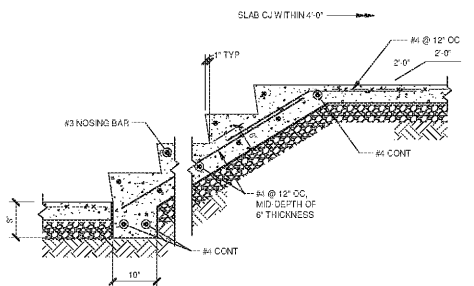

**INTERIOR CONCRETE STAIR DETAIL**

NO SCALE

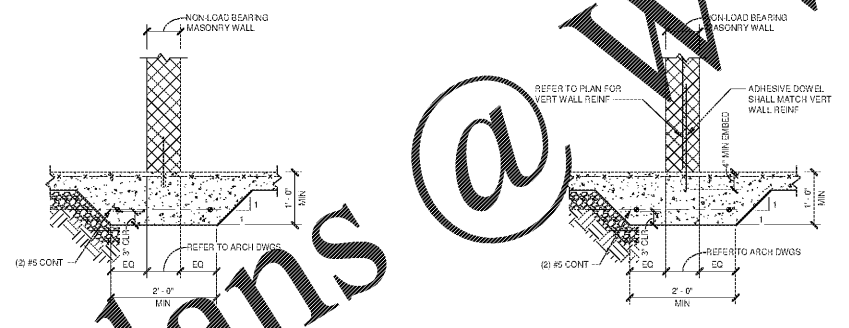

**THICKENED SLAB ON GRADE DETAILS**

NO SCALE

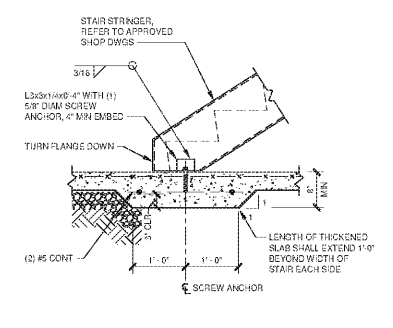

**STAIR**

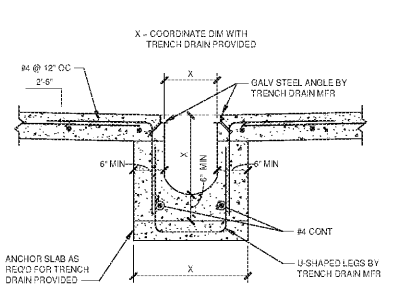

**TRENCH DRAIN DETAIL**

NO SCALE

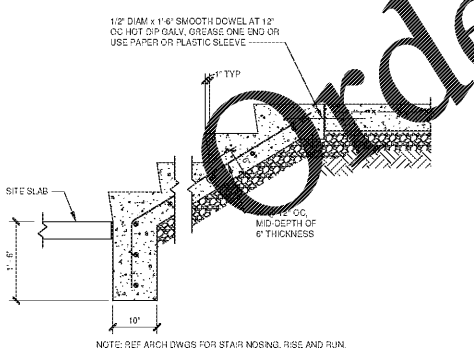

**EXTERIOR CONCRETE STAIR DETAIL**

NO SCALE

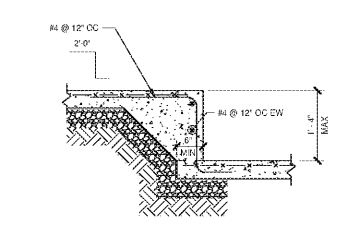

**STEP IN SLAB ON GRADE**

NO SCALE

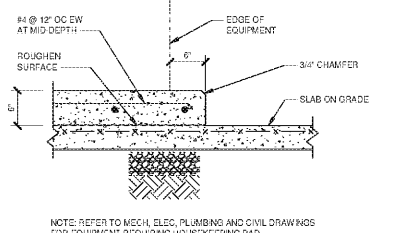

**HOUSEKEEPING PAD**

**EQUIPMENT PAD DETAILS**

NO SCALE

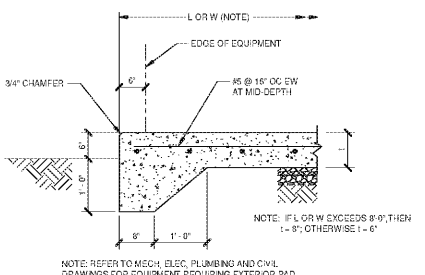

**EXTERIOR EQUIPMENT PAD**

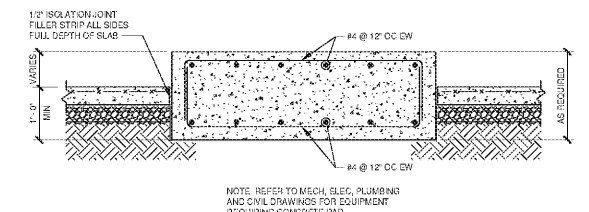

**HEAVY EQUIPMENT PAD**

**MOSELEYARCHITECTS**

6210 ARDREY KELL ROAD - THE HUB AT WAVERLY, SUITE 405 - CHARLOTTE, NC 28277  
PHONE (704) 540-3755 FAX (704) 540-3754  
MOSELEYARCHITECTS.COM



**MARION COUNTY LEC**

591492  
MARION COUNTY  
2715 EAST HWY 76, MULLINS, SC 29574

DATE	REVISIONS	DESCRIPTION
10/30/2020	591492	OCTOBER 30, 2020

TYPICAL SLAB DETAILS

**S3.0.2**

Order Plans @ WWW.LDOnline.com

10/30/2020 4:10:41 PM