

1 GROUP SALES ROOM INTERIOR ELEVATION  
HUB3 SCALE: 1/4" = 1'-0"

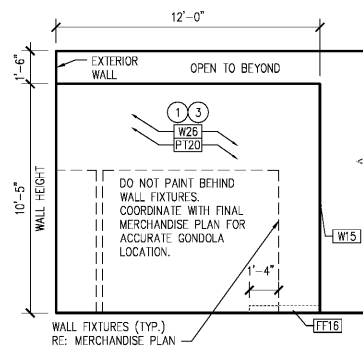

5 GROUP SALES ROOM EXTERIOR ELEVATION  
HUB3 SCALE: 1/4" = 1'-0"

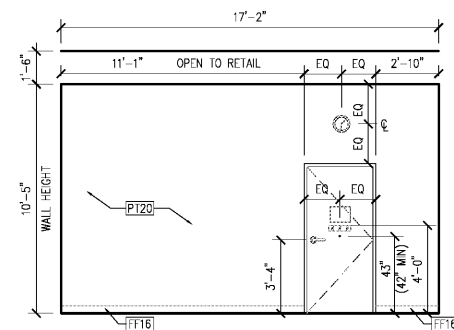

2 GROUP SALES ROOM INTERIOR ELEVATION  
HUB3 SCALE: 1/4" = 1'-0"

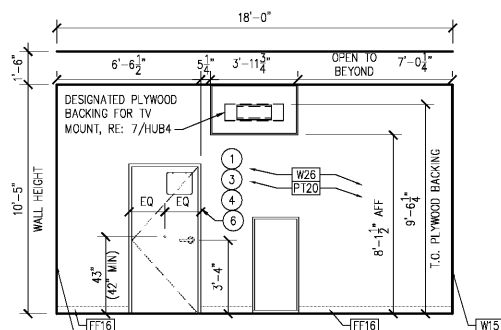

6 GROUP SALES ROOM EXTERIOR ELEVATION  
HUB3 SCALE: 1/4" = 1'-0"

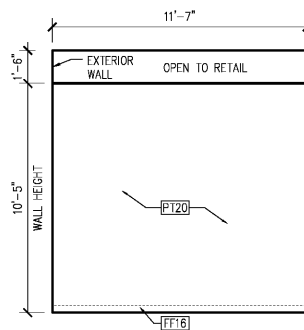

3 GROUP SALES ROOM INTERIOR ELEVATION  
HUB3 SCALE: 1/4" = 1'-0"

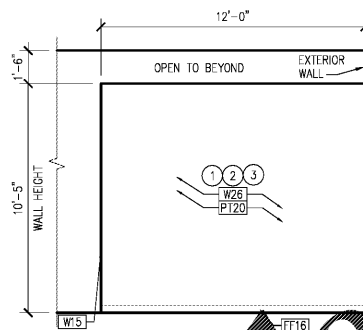

7 GROUP SALES ROOM EXTERIOR ELEVATION  
HUB3 SCALE: 1/4" = 1'-0"

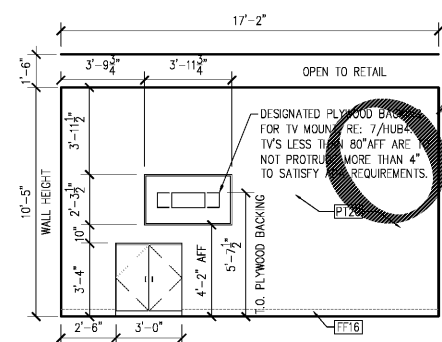

4 GROUP SALES ROOM INTERIOR ELEVATION  
HUB3 SCALE: 1/4" = 1'-0"

LEGEND	
XX	FINISH DESIGNATION - REFERENCE FINISH SCHEDULE

NOTES BY SYMBOL	
1	INSTALL NEW WALL COVERING AS SHOWN/SCHEDULED.
2	INSTALL NEW CHAIR RAIL AS SHOWN/SCHEDULED.
3	WALL TO RECEIVE A LEVEL 5 GYPSUM BOARD FINISH IN ACCORDANCE WITH LEVELS DEFINED IN ASTM C840. PRIME WITH P120 AS SCHEDULED.
4	DEMOLISH EXISTING WALL COVERING, TRIM, AND LAMINATE. SKIM COAT AS REQUIRED.
5	PATCH/PAINT AS SHOWN/SCHEDULED.
6	PAINT DOOR FRAME ONLY P120 STAIN DOOR P125

Order Plans @ www.LDILine.com



HEALTH HUB/Rx CONSULTATION  
STORE NUMBER: 4176

11 RIVER RIDGE DRIVE, OAKLEY PLAZA  
ASHEVILLE, NC 28803  
CAP CODE: 90

CS PROJECT NUMBER: 146740

ARCHITECT OF RECORD:

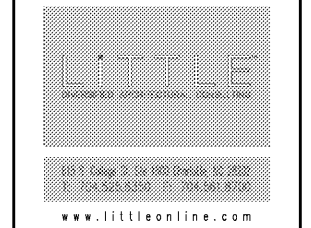

This drawing and the design shown are the property of Little Architectural. Any reproduction, copying or alteration of this drawing without their written consent is prohibited and any infringement will be subject to legal action.

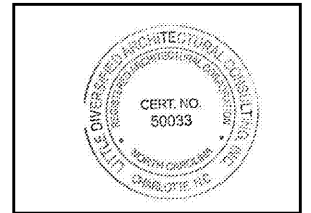

DEVELOPER:



SEAL:

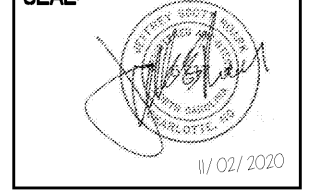

REVISIONS:

DRAWING BY: JC

CVS PROJECT MANAGER: RJ

DATE: 11-02-2020

JOB NUMBER: 121-14217-08

TITLE: HEALTHHUB ELEVATIONS

SHEET NUMBER:

HUB3

COMMENTS: