

LEGEND

TYPICAL NOTE TEXT	NOTE
PROPERTY LINE / R.O.W. LINE	---
NEIGHBORING PROPERTY LINE / INTERIOR PARCEL LINE	---
EXIST. OVERHEAD WIRE	----
EXIST. STORM SEWER	----
EXIST. SANITARY LINE	----
EXIST. WATER LINE	----
EXIST. SPOT ELEVATION	xx
EXIST. TREE	xx
EXIST. TREE TO BE REMOVED	xx*
EXIST. POWER POLE	o
EXISTING CONCRETE	-----
EXIST. SIGN	-----
PROP. SILT FENCE	SF-----SF
PROP. INLET PROTECTION	-----
STABILIZED CONSTRUCTION ENTRANCE/EXIT	-----
TO BE REMOVED	(TBR)

DATUM NOTE:

ELEVATIONS SHOWN HEREON ARE IN FEET AND ARE REFERENCES TO THE NORTH AMERICAN HORIZONTAL DATUM OF 1988 (NAVD88).

FEMA NOTE:

THE SUBJECT PROPERTY LIES IN FLOOD ZONE "X" ACCORDING TO FLOOD INSURANCE RATE MAP, MAP NO. 12024C0058 FOR CITY OF JACKSONVILLE, FLORIDA, COMMUNITY, DATED JUNE 3, 2013 AND ISSUED BY THE FEDERAL EMERGENCY MANAGEMENT AGENCY.

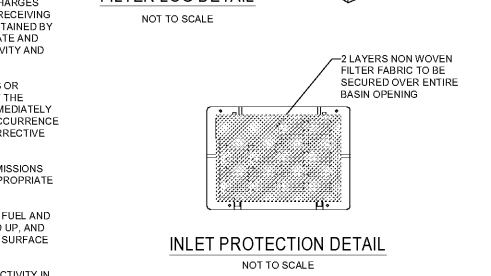
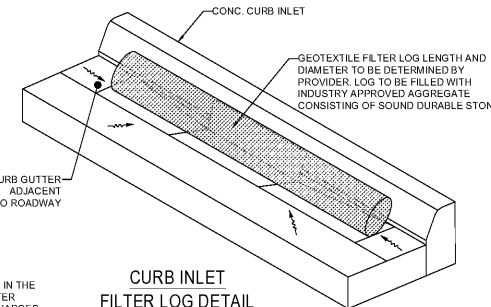

DEMOLITION NOTES:

- BOHLER ENGINEERING, FL, LLC IS NOT RESPONSIBLE FOR JOB SITE SAFETY OR SUPERVISION. CONTRACTOR IS TO PROCEED WITH THE DEMOLITION IN A SYSTEMATIC AND SAFE MANNER, FOLLOWING ALL THE OSHA REQUIREMENTS, TO ENSURE PUBLIC AND CONTRACTOR SAFETY.
- ALL DEMOLITION ACTIVITIES ARE TO BE PERFORMED IN ACCORDANCE WITH THESE PLANS AND SPECIFICATIONS AS WELL AS ALL FEDERAL, STATE AND LOCAL REGULATIONS. ANY DISCREPANCIES OR DEVIATIONS SHALL BE THE CONTRACTOR TO PROVIDE THE OWNER WRITTEN NOTIFICATION IN WRITING FOR RESOLUTION PRIOR TO INITIATION OF SITE ACTIVITY.
- PRIOR TO STARTING ANY DEMOLITION CONTRACTOR IS RESPONSIBLE FOR THE FOLLOWING:
 - THE CONTRACTOR SHALL OBTAIN A SUNSHINE STATE IDENTIFICATION CERTIFICATION PRIOR TO ANY EXCAVATION OR DEMOLITION. THE NUMBER IS 1-800-432-4343.
 - ENSURING COPIES OF ALL PERMITS AND APPROVALS ARE TO BE MAINTAINED ON SITE AND AVAILABLE FOR REVIEW.
 - INSTALLING THE REQUIRED SOIL EROSION AND SEDIMENT CONTROL MEASURES PRIOR TO SITE DISTURBANCE.
 - LOCATING ALL UTILITIES AND SERVICES, INCLUDING BUT NOT LIMITED TO GAS, WATER, ELECTRIC, SANITARY AND STORM SEWER, TELEPHONE, CABLE, FIBER OPTIC CABLE, ETC. WITHIN THE LIMITS OF DISTURBANCE.
 - PROTECTING AND MAINTAINING IN OPERATION, ALL ACTIVE SYSTEMS THAT ARE NOT BEING REMOVED DURING ALL DEMOLITION ACTIVITIES.
 - FAMILIARIZING THEMSELVES WITH THE APPLICABLE UTILITY SERVICE PROVIDER AND BEING RESPONSIBLE FOR ALL COORDINATION REGARDING UTILITY DEMOLITION REQUIRED FOR THE PROJECT. THE CONTRACTOR SHALL PROVIDE THE OWNER WRITTEN NOTIFICATION THAT THE EXISTING UTILITIES AND SERVICES HAVE BEEN TERMINATED AND ABANDONED IN ACCORDANCE WITH JURISDICTION AND UTILITY COMPANY REQUIREMENTS.
 - COORDINATION WITH UTILITY COMPANIES REGARDING WORKING "OFF-PEAK" HOURS OR ON WEEKENDS AS MAY BE REQUIRED TO MINIMIZE THE IMPACT ON THE AFFECTED PARTIES.
 - A COMPLETE INSPECTION OF CONTAMINANTS BY A LICENSED ENVIRONMENTAL TESTING AGENCY, OF ALL BUILDINGS AND/OR STRUCTURES TO BE REMOVED. SAME SHALL BE PERFORMED IN ACCORDANCE WITH ALL APPLICABLE LOCAL, STATE, AND FEDERAL ENVIRONMENTAL REGULATIONS. ANY/ALL CONTAMINANTS SHALL BE REMOVED AND DISPOSED OF BY A FEDERALLY LICENSED CONTRACTOR IN ACCORDANCE WITH FEDERAL, STATE, AND LOCAL REGULATIONS. ALL ENVIRONMENTAL WORK INCLUDING HAZARDOUS MATERIAL, SOILS, ASBESTOS, OR OTHER REFERENCED OR IMPLIED HEREIN IS THE SOLE RESPONSIBILITY OF THE OWNER'S ENVIRONMENTAL CONSULTANT.
- THE CONTRACTOR SHALL PROVIDE ALL THE "MEANS AND METHODS" NECESSARY TO PREVENT ADJACENT SETTLEMENT OR COLLAPSE OF EXISTING STRUCTURES, AND ANY OTHER ADJACENT STRUCTURES THAT ARE REMAINING ON OR OFF SITE. THE DEMOLITION CONTRACTOR IS RESPONSIBLE FOR ALL REPAIRS OF DAMAGE TO ALL ITEMS THAT ARE TO REMAIN AS A RESULT OF HIS ACTIVITIES. ALL REPAIRS SHALL USE NEW MATERIAL. THE REPAIRS SHALL RESTORE THE ITEM TO THE PRE-DEMOLITION CONDITION.
- IN THE ABSENCE OF SPECIFICATIONS, THE CONTRACTOR SHALL PERFORM EARTH MOVEMENT ACTIVITIES, DEMOLITION AND REMOVAL OF ALL FOUNDATION WALLS, FOOTINGS, AND OTHER MATERIALS WITHIN THE LIMITS OF DISTURBANCE IN ACCORDANCE WITH DIRECTION BY OWNER'S STRUCTURAL OR GEOTECHNICAL ENGINEER.
- EXPLOSIVES SHALL NOT BE USED WITHOUT PRIOR WRITTEN CONSENT OF BOTH THE OWNER AND APPLICABLE GOVERNMENTAL AUTHORITIES. ALL THE REQUIRED PERMITS AND EXPLOSIVE CONTROL MEASURES THAT ARE REQUIRED BY THE FEDERAL, STATE, AND LOCAL GOVERNMENTS SHALL BE IN PLACE PRIOR TO STARTING AN EXPLOSIVE PROGRAM. THE CONTRACTOR IS ALSO RESPONSIBLE FOR ALL INSPECTION AND SEISMIC VIBRATION TESTING THAT IS REQUIRED TO MONITOR THE EFFECTS ON ALL LOCAL STRUCTURES.
- CONTRACTOR SHALL PROVIDE TRAFFIC CONTROL AND GENERALLY ACCEPTED SAFE PRACTICES IN CONFORMANCE WITH THE "MANUAL ON UNIFORM TRAFFIC CONTROL," AS WELL AS FEDERAL, STATE, AND LOCAL REGULATIONS WHEN DEMOLITION RELATED ACTIVITIES IMPACT ROADWAYS OR ROADWAY RIGHTS-OF-WAY.
- CONTRACTOR SHALL DEVELOP AND IMPLEMENT A PLAN TO ASSURE THAT ALL WASTE, SUCH AS DISCARDED BUILDING MATERIALS, CONCRETE TRUCK WASH-OUT, CHEMICALS, LITTER AND SANITARY WASTE, ARE PROPERLY CONTROLLED WHILE ON-SITE AND TRANSPORTED AND DISPOSED OF (OFF-SITE) IN ACCORDANCE WITH ALL APPLICABLE LOCAL, STATE AND FEDERAL REGULATIONS. NO WASTE MATERIALS OF ANY KIND ARE PERMITTED TO BE BURIED ON-SITE OR DISCHARGED TO SURFACE WATERS OF THE STATE OR TO THE CITY STORM WATER SYSTEM.
- CONTRACTOR SHALL PERIODICALLY SWEEP EXISTING ON-SITE PAVED SURFACES AS WELL AS ALL ADJUTING CITY STREETS, COUNTY ROADS AND STATE HIGHWAYS (AS APPROPRIATE FOR THE PARTICULAR PROJECT) TO KEEP THOSE SURFACES IN SUBSTANTIALLY SEDIMENT-FREE CONDITION. SWEEPING SHALL BE DONE ON A PERIODIC, AS-NEEDED BASIS THROUGHOUT THE WORK WEEK INCLUDING, MOST IMPORTANTLY, AFTER EVERY RAIN EVENT AND EVERY FRIDAY AFTERNOON PRIOR TO CEASING WORK FOR THE WEEK.

POLLUTION PREVENTION NOTES:

- CONDUCT DEMOLITION ACTIVITIES IN SUCH A MANNER TO ENSURE MINIMUM INTERFERENCE WITH ROADS, STREETS, SIDEWALKS, WALKWAYS, AND OTHER ADJACENT FACILITIES. STREET CLOSURE PERMITS MUST BE RECEIVED FROM THE APPROPRIATE GOVERNMENTAL AUTHORITY.
- ALL MATERIALS, MACHINERY AND VEHICLES SHALL BE STORED ON-SITE IN AN ORDERLY ORGANIZED FASHION.
- DEMOLITION ACTIVITIES AND EQUIPMENT SHALL NOT USE AREAS OUTSIDE THE DEFINED PROPERTY LINE WITHOUT WRITTEN PERMISSION OF THE OWNER, AND/OR APPROPRIATE GOVERNMENT AGENCY.
- USE DUST CONTROL MEASURES TO LIMIT AIRBORNE DUST AND DIRT RISING AND SCATTERING IN THE AIR IN ACCORDANCE WITH FEDERAL, STATE, AND LOCAL STANDARDS. AFTER THE DEMOLITION IS COMPLETE, ADJACENT STRUCTURES AND IMPROVEMENTS SHALL BE CLEANED OF ALL DUST AND DEBRIS CAUSED BY THE DEMOLITION OPERATIONS. THE CONTRACTOR IS RESPONSIBLE FOR RETURNING ALL ADJACENT AREAS TO THEIR "PRE-DEMOLITION" CONDITION.
- CONTRACTOR IS RESPONSIBLE TO SAFEGUARD SITE AS NECESSARY TO PERFORM THE DEMOLITION IN SUCH A MANNER AS TO PREVENT THE ENTRY OF UNAUTHORIZED PERSONS AT ANY TIME.
- THIS DEMOLITION PLAN IS INTENDED TO IDENTIFY THOSE EXISTING ITEMS/CONDITIONS WHICH ARE TO BE REMOVED. IT IS NOT INTENDED TO PROVIDE DIRECTION OTHER THAN THAT ALL METHODS AND MEANS ARE TO BE IN ACCORDANCE WITH STATE, FEDERAL, LOCAL, AND JURISDICTIONAL REQUIREMENTS. THE CONTRACTOR SHALL BE RESPONSIBLE FOR ALL OSHA AND OTHER SAFETY PRECAUTIONS NECESSARY TO PROVIDE A SAFE WORK SITE.
- DEBRIS SHALL NOT BE BURIED ON THE SUBJECT SITE. ALL DEMOLITION WASTES AND DEBRIS (SOLID WASTE) SHALL BE DISPOSED OF IN ACCORDANCE WITH ALL TOWN, COUNTY, STATE, AND FEDERAL LAWS AND APPLICABLE CODES.
- CONTRACTOR IS RESPONSIBLE FOR FIELD VERIFYING ALL EXISTING SITE IMPROVEMENTS AND UTILITIES. ALL DISCREPANCIES MUST BE IDENTIFIED TO THE ENGINEER IN WRITING.
- ALL EXISTING UTILITIES BEING REMOVED SHALL BE DONE SO BY THE CONTRACTOR IN ACCORDANCE WITH STATE AND LOCAL REGULATIONS.
- EROSION AND SEDIMENT CONTROL (BMPs) IN ADDITION TO THOSE PRESENTED ON THE PLANS AND OUTLINED IN THE EROSION AND SEDIMENT CONTROL PLAN (ECP), BEST MANAGEMENT PRACTICES (BMP) PLAN, OR STORMWATER POLLUTION PREVENTION PLAN (SWPPP) SHALL BE IMPLEMENTED AS NECESSARY TO PREVENT TURBID DISCHARGES FROM FLOWING ONTO ADJACENT PROPERTIES OR ROADWAYS. OFF-SITE STORMWATER CONVEYANCES OR RECEIVING WATERS OR ON-SITE WETLANDS AND SURFACE WATERS. BMPs SHALL BE DESIGNED, INSTALLED, AND MAINTAINED BY THE SITE OPERATOR TO ENSURE THAT OFF-SITE SURFACE WATER QUALITY REMAINS CONSISTENT WITH STATE AND LOCAL REGULATIONS. [THE OPERATOR IS THE ENTITY THAT OWNS OR OPERATES THE CONSTRUCTION ACTIVITY AND HAS AUTHORITY TO CONTROL THOSE ACTIVITIES AT THE PROJECT NECESSARY TO ENSURE COMPLIANCE.]
- IF CONTAMINATED SOIL AND/OR GROUNDWATER IS DISCOVERED DURING DEVELOPMENT OF THE SITE, ALL ACTIVITY IN THE VICINITY OF THE CONTAMINATION SHALL IMMEDIATELY CEASE, AND AIR & WATER QUALITY SHALL BE CONTACTED (PH: 941.861.5000; FAX: 941.861.0986). THE REPORT SHALL INCLUDE THE CAUSE OF THE DISCHARGE AND CORRECTIVE ACTIONS TAKEN.
- IF FUEL AND OTHER PETROLEUM PRODUCT SPILLS THAT ENTER STORMWATER DRAINS OR WATER BODIES, OR FUEL AND OTHER PETROLEUM PRODUCT SPILLS THAT ARE IN EXCESS OF 25 GALLONS SHALL BE CONTAINED, CLEANED UP, AND IMMEDIATELY REPORTED TO AIR & WATER QUALITY (PH: 941.861.5000; FAX: 941.861.0986). SMALLER GROUND SURFACE SPILLS SHALL BE CLEANED UP AS SOON AS PRACTICAL.
- IF CONTAMINATED SOIL AND/OR GROUNDWATER IS DISCOVERED DURING DEVELOPMENT OF THE SITE, ALL ACTIVITY IN THE VICINITY OF THE CONTAMINATION SHALL IMMEDIATELY CEASE, AND AIR & WATER QUALITY SHALL BE CONTACTED (PH: 941.861.5000; FAX: 941.861.0986).
- PRIOR TO DEMOLITION OF EXISTING ON-SITE STRUCTURES AN ASBESTOS SURVEY AND/OR ASBESTOS NOTIFICATION MAY BE REQUIRED.
- NATIONAL POLLUTANT DISCHARGE ELIMINATION SYSTEM:
 - NPDES CONSTRUCTION GENERIC PERMIT COVERAGE SHALL BE OBTAINED AT LEAST 48 HOURS IN ADVANCE OF CONSTRUCTION COMMENCEMENT IN ACCORDANCE WITH RULE 62-21.300(4)(A), F.A.C.

BOHLER ENGINEERING

SITE CIVIL AND CONSULTING ENGINEERING
 SUSTAINABLE DESIGN
 PERMITTING SERVICES
 TRANSPORTATION SERVICES

CHARLOTTE, NC
 BALTIMORE, MD
 BIRMINGHAM, AL
 CHARLOTTE, NC
 CHICAGO, IL
 COLUMBIA, SC
 DALLAS, TX
 DENVER, CO
 FORT LAUDERDALE, FL
 HOUSTON, TX
 JACKSONVILLE, FL
 KANSAS CITY, MO
 LOS ANGELES, CA
 MEMPHIS, TN
 MIAMI, FL
 MINNEAPOLIS, MN
 NEW YORK, NY
 OKLAHOMA CITY, OK
 PHOENIX, AZ
 RICHMOND, VA
 SAN ANTONIO, TX
 TAMPA, FL
 WASHINGTON, DC

REVISIONS

REV	DATE	COMMENT	BY
1	01/08/18	PER CITY & JEA COMMENTS	JRT
2	03/06/18	PER CITY & FDOT COMMENTS	JRT
3	04/16/18	PER FDOT COMMENTS	JRT
4	01/28/20	FORCE MAIN & IRRIGATION REVISION	ASZ
5	02/11/20	EOD COMMENTS	ASZ
6	09/25/20	PER WAWA	KM

811 KNOW WHAT'S BELOW ALWAYS CALL 811 BEFORE YOU DIG

It's fast. It's free. It's the law.

www.callsunshine.com

PERMIT SET

PROJECT No.: FL1770094
 DRAWN BY: JRT
 CHECKED BY: ASZ
 DATE: 9/28/20
 SCALE: AS NOTED
 CAD I.D.: OAZ

Wawa FOR BRIGHTWORK REAL ESTATE

LOCATION OF SITE
 1004 EDGEWOOD AVE NORTH
 JACKSONVILLE, FL 32254
 CITY OF JACKSONVILLE

BOHLER ENGINEERING

3820 NORTHALE BLVD., SUITE 300B
 TAMPA, FLORIDA 33624
 Phone: (813) 812-4100
 Fax: (813) 812-4101
 FLORIDA BUSINESS CERT. # OF AUTH. No. 30789
 LICENSE # 00000000000000000000000000000000

SOIL EROSION CONTROL PHASE I & DEMO PLAN

SHEET NUMBER: **C-3**