



© 2019 STARBUCKS COFFEE COMPANY

STARBUCKS
2401 UTAH AVENUE SOUTH
SEATTLE, WASHINGTON 98134
(206) 318-1575

THESE DRAWINGS AND THE PROJECT MANUAL ARE CONFIDENTIAL AND SHALL REMAIN THE SOLE PROPERTY OF STARBUCKS CORPORATION, WHICH IS THE OWNER OF THE COPYRIGHT IN THIS WORK. THEY SHALL NOT BE REPRODUCED IN WHOLE OR IN PART, SHARED WITH THIRD PARTIES OR USED IN ANY MANNER ON OTHER PROJECTS OR EXTENSIONS TO THIS PROJECT WITHOUT THE PRIOR WRITTEN CONSENT OF STARBUCKS CORPORATION. THESE DRAWINGS AND SPECIFICATIONS ARE INTENDED TO EXPRESS DESIGN INTENT FOR A PROTOTYPICAL STARBUCKS STORE (WHICH IS SUBJECT TO CHANGE AT ANYTIME) AND DO NOT REFLECT ACTUAL SITE CONDITIONS. NEITHER PARTY SHALL HAVE ANY OBLIGATION OR LIABILITY TO THE OTHER EXCEPT AS STATED ABOVE UNTIL A WRITTEN AGREEMENT IS FULLY EXECUTED BY BOTH PARTIES.

STARBUCKS TEMPLATE VERSION: I2020-02-10

Design Forum Architects Inc.
2506 Byers Rd
Miamisburg, OH 45342
Tel: (844) 804-7700
Donald J. Rehrman
Architect In Charge
License: AR0017303

Design Forum Engineering
2506 Byers Rd
Miamisburg, OH 45342
Tel: (844) 804-7700
Timothy L. Raderding, P.E.
Professional Engineer
License: 62078

PROJECT NAME:
HARDEN & POLK

PROJECT ADDRESS:
1310 LAKESIDE VILLAGE CIR
LAKELAND, FL 33803

STORE #: 2965
PROJECT #: 21120-060
ISSUE DATE: 08/17/20
DESIGNER: RAI MONTERO
PRODUCTION DESIGNER: ANDY MCLLOUD
CHECKED BY: RAI MONTERO

Revision Schedule			
Rev	Date	By	Description

SHEET TITLE:
ACCESSIBILITY GUIDELINES
SCALE: NO SCALE

SHEET NUMBER:
G-003

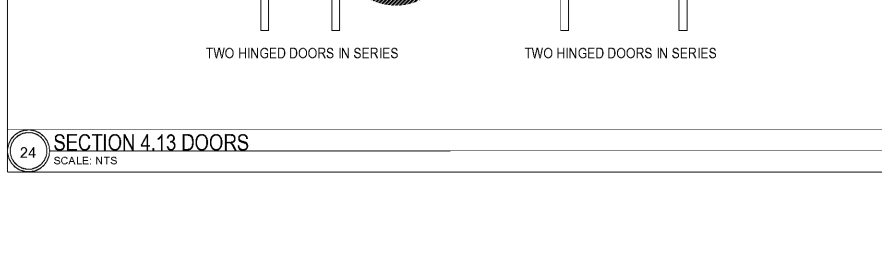
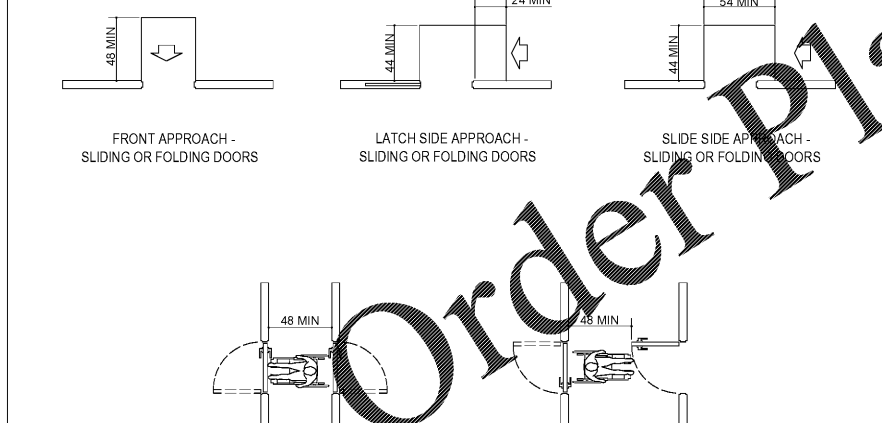
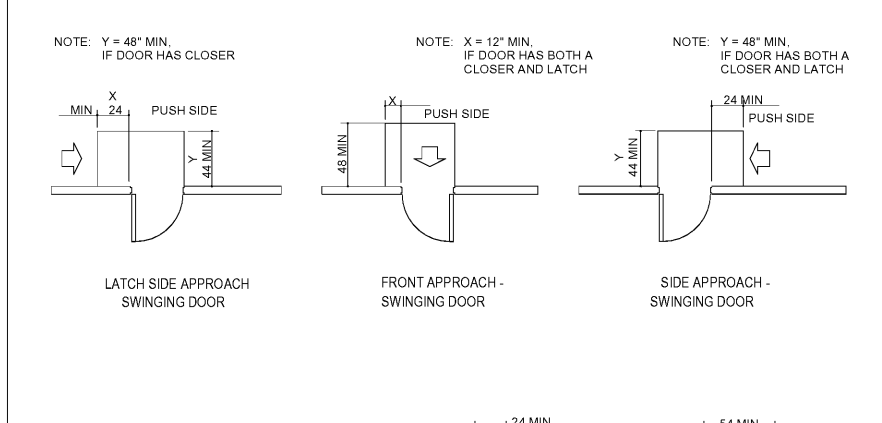
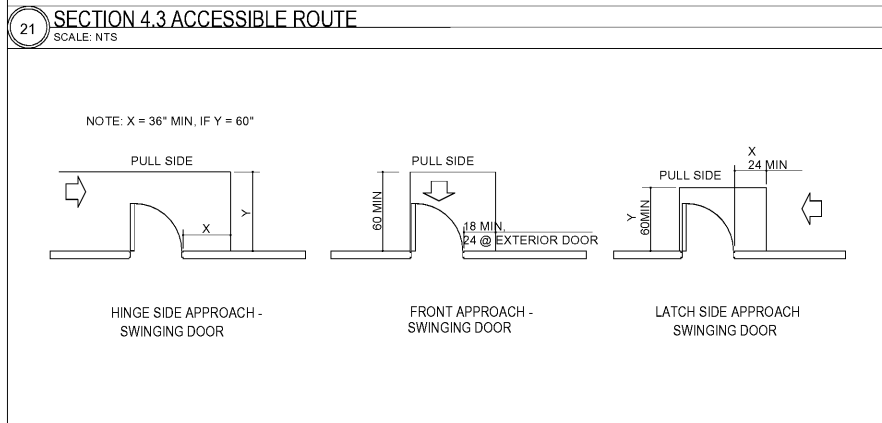
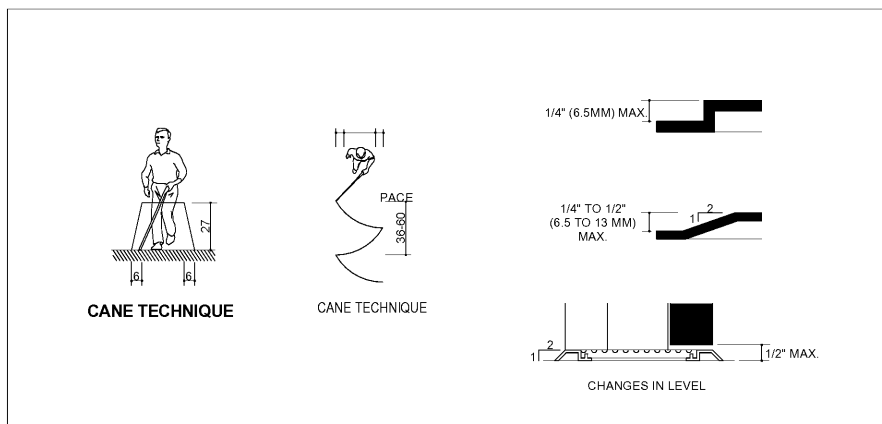
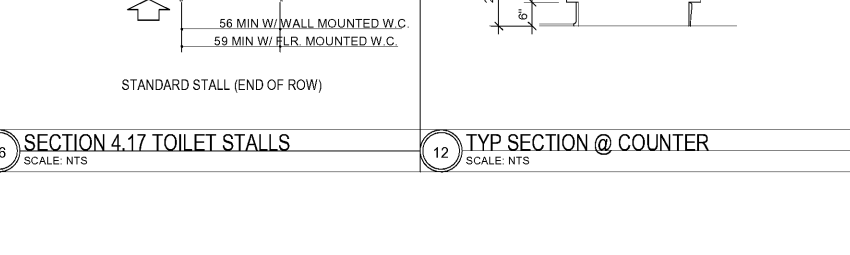
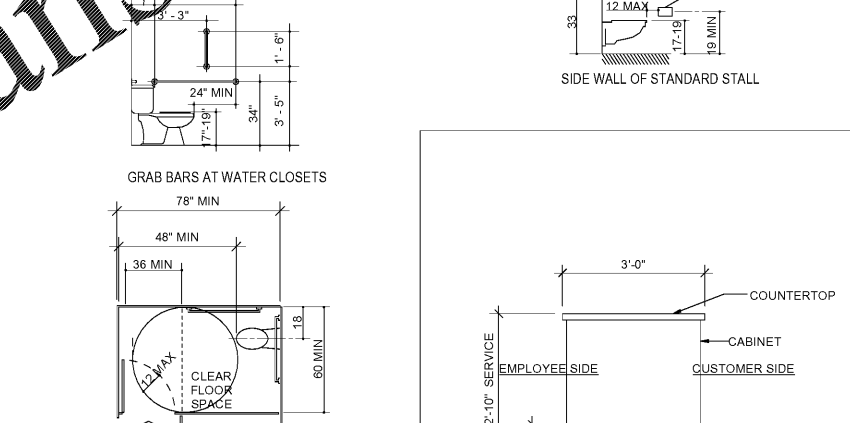
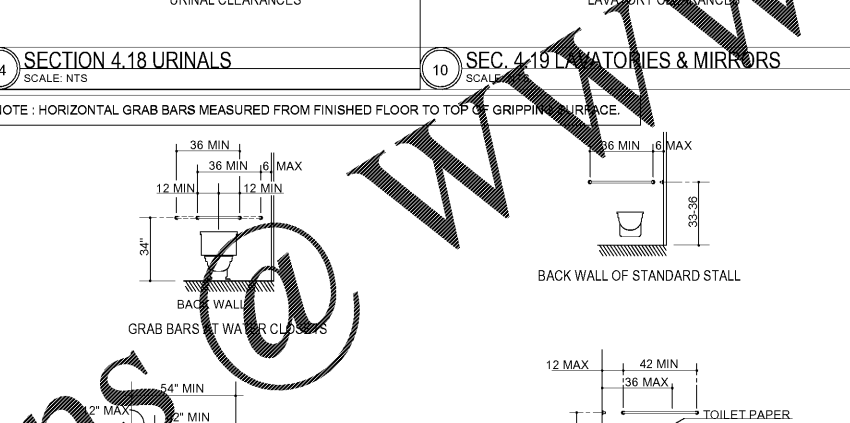
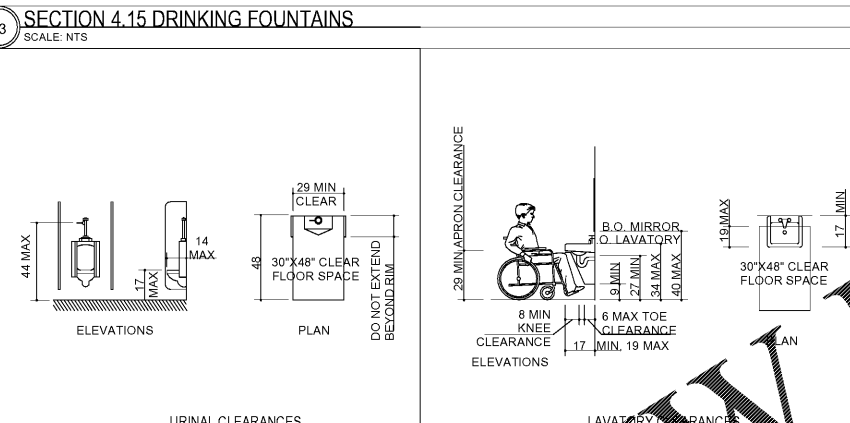
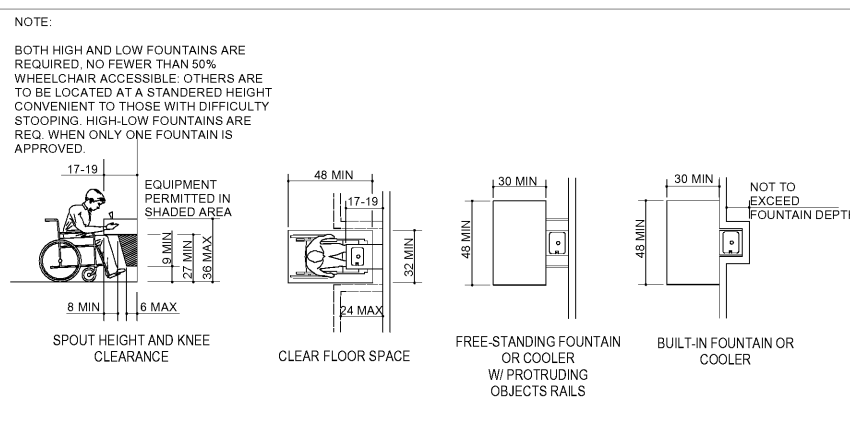
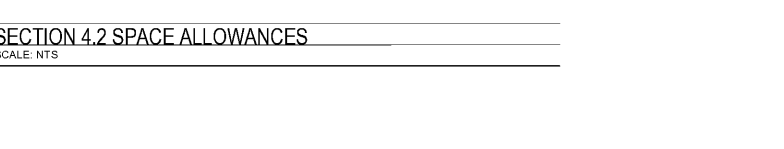
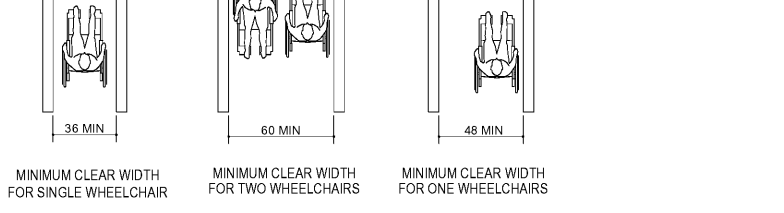
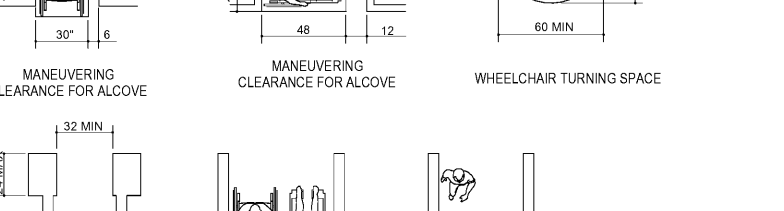
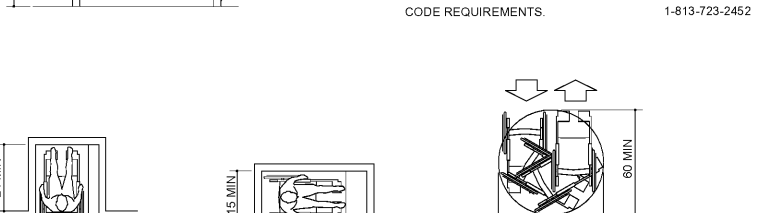
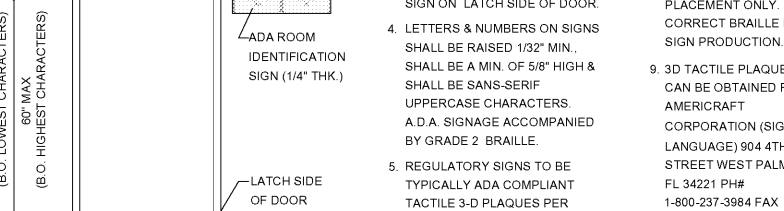
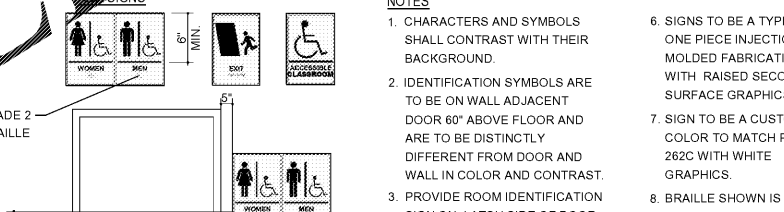
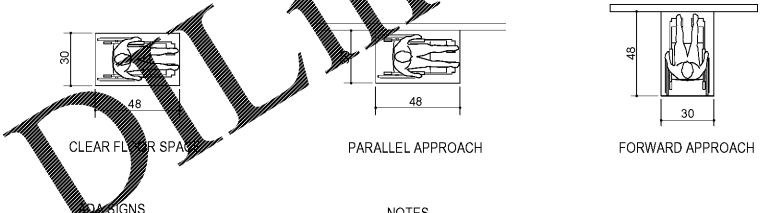
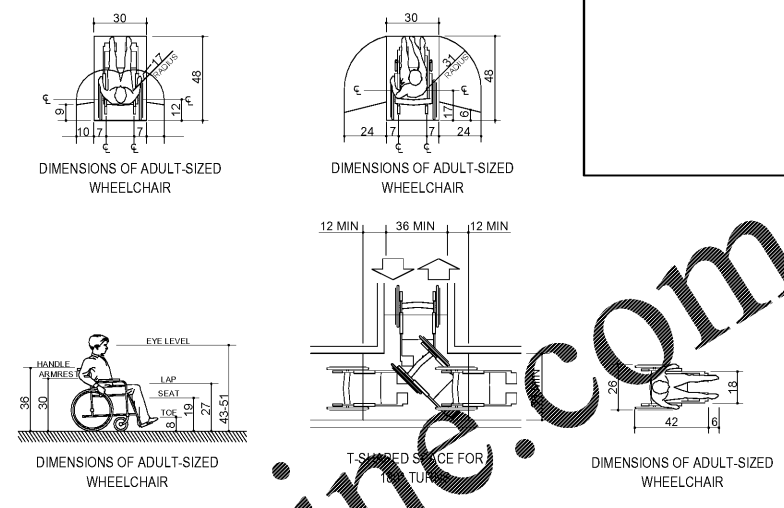

8/13/2020 4:18:13 PM C:\Users\julia.gray\Documents\21120-060_2965_Harden & Polk_julia.gray.rvt