

FOR BIDDING ONLY
09/03/2020

NO.	DATE	REVISIONS	REMARKS
1	04/27/20	PEER COMMENTS	
		NO. DATE	REMARKS



7-ELEVEN
STORE #41559

1245 S. VOLUSIA AVENUE
Orlando City, FL 32763

PROJECT NO: 2019.0743
DATE: APRIL 7, 2020

A7.0
DETAILS

CHECKED: RW DRAWN: JM

JENARS - 09/01/2020 11:26:10 AM

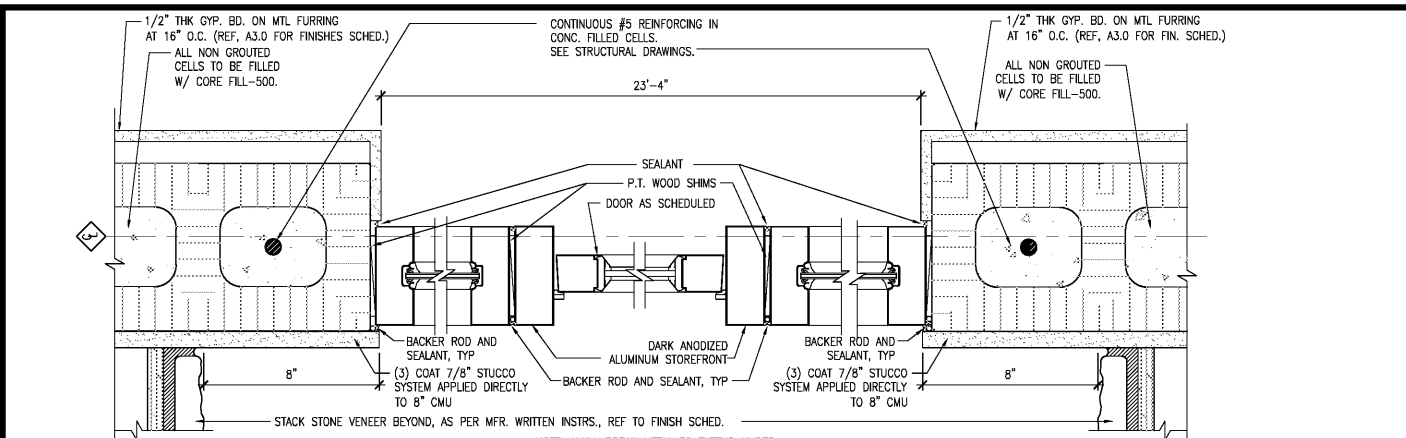

1 STOREFRONT JAMB DETAIL 3" = 1'-0"

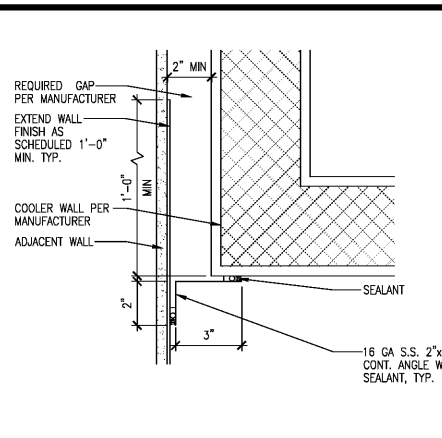

2 CLOSURE STRIP AT COOLER 3" = 1'-0"

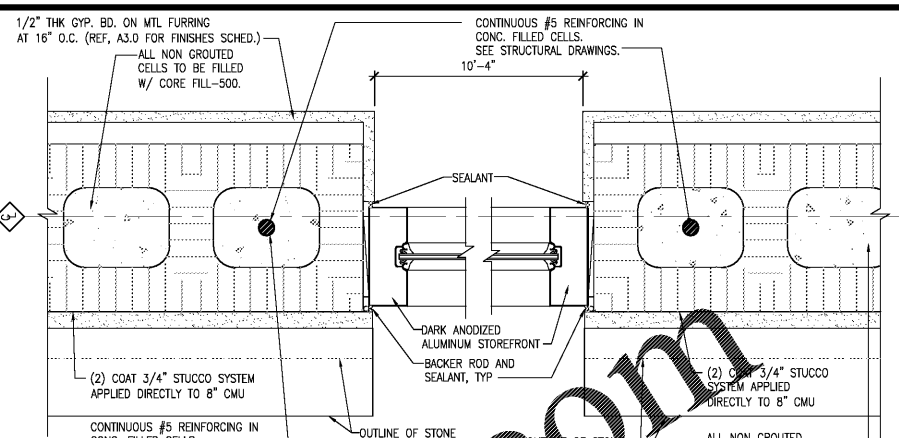

3 STOREFRONT JAMB DETAIL 3" = 1'-0"

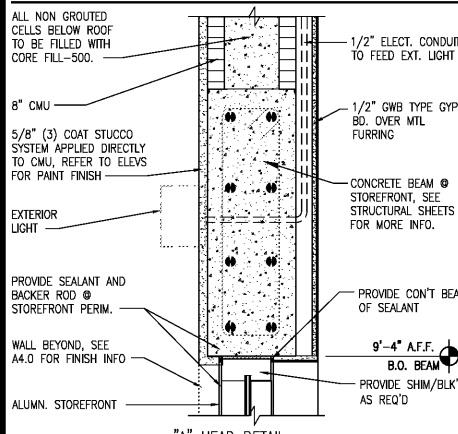

4 STOREFRONT HEAD/SILL 1 1/2" = 1'-0"

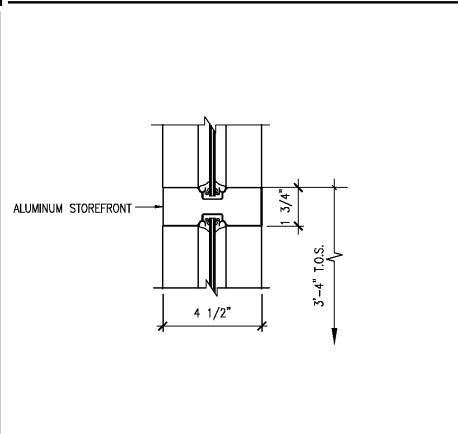

5 STOREFRONT HORIZONTAL MULLION 3" = 1'-0"

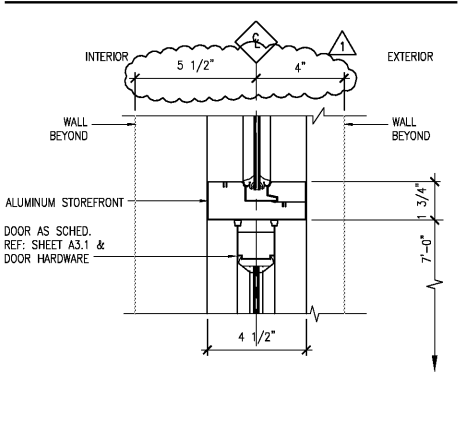

6 STOREFRONT DOOR HEAD DETAIL 3" = 1'-0"

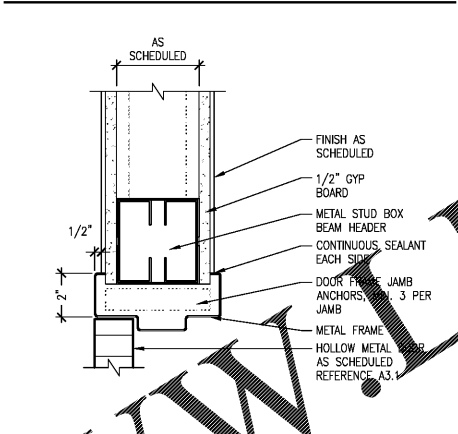

7 INTERIOR DOOR JAMB/HEAD 3" = 1'-0"

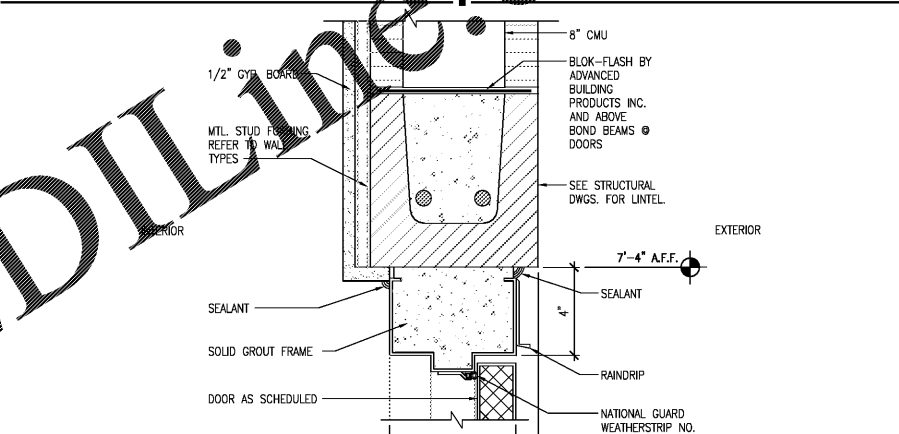

8 EXT. DOOR HEAD DETAIL 3" = 1'-0"

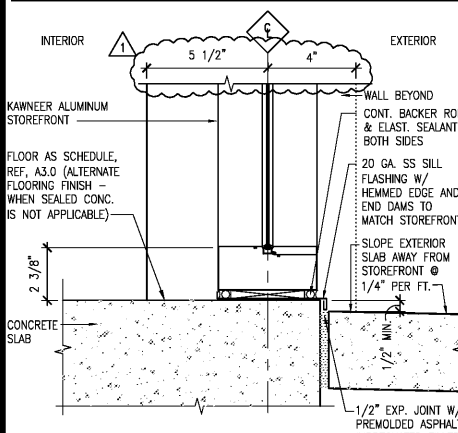

9 STOREFRONT SILL DETAIL 3" = 1'-0"

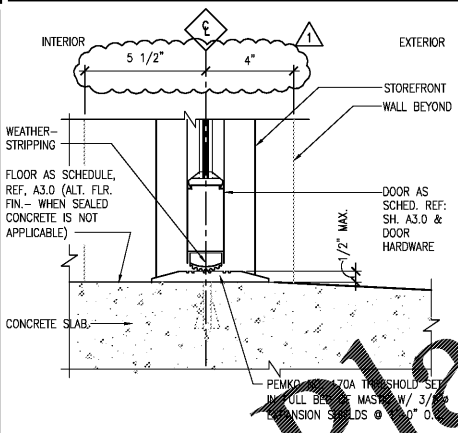

10 STOREFRONT DOOR SILL DETAIL 3" = 1'-0"

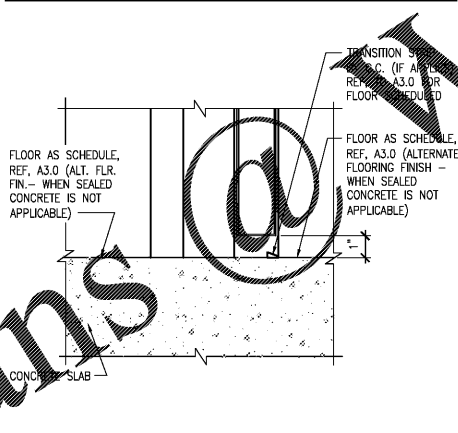

11 INT. DOOR SILL DETAIL 3" = 1'-0"

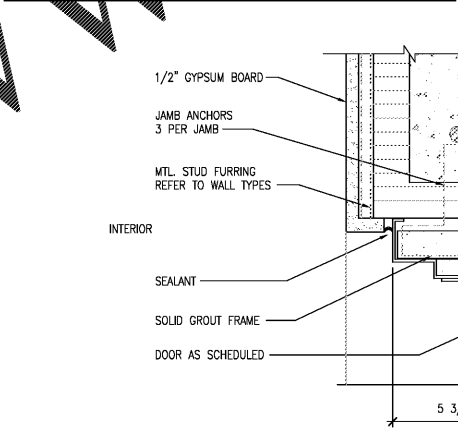

12 EXT. DOOR JAMB DETAIL 3" = 1'-0"

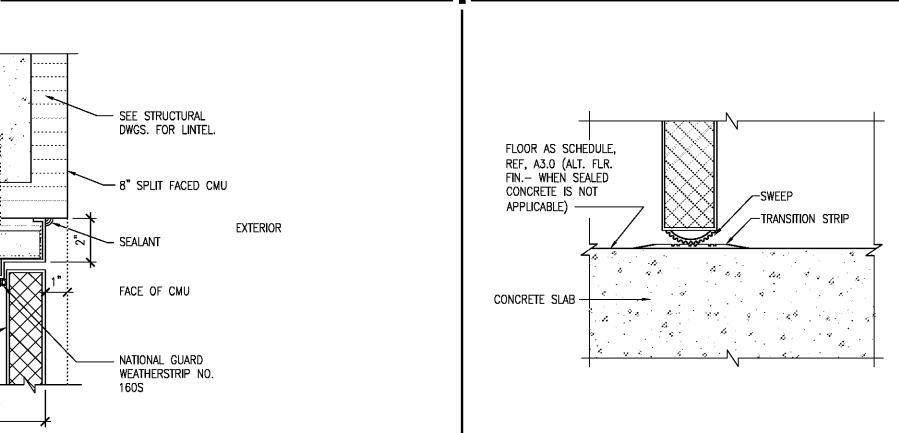

13 VAULT DOOR SILL DETAIL 3" = 1'-0"

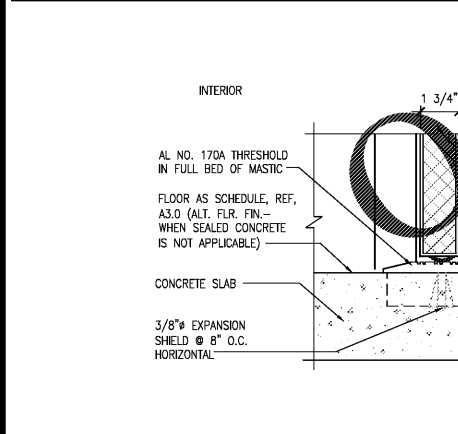

14 EXT. DOOR SILL DETAIL 3" = 1'-0"

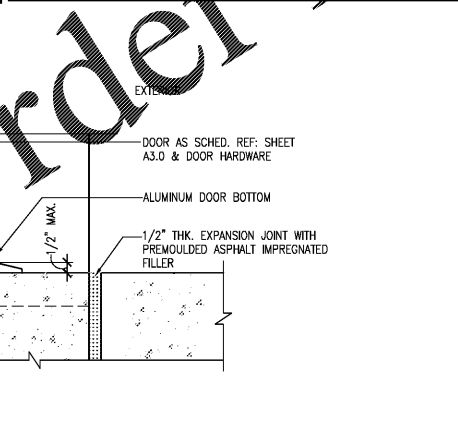

15 PILASTER BUILD-OUT 1 1/2" = 1'-0"

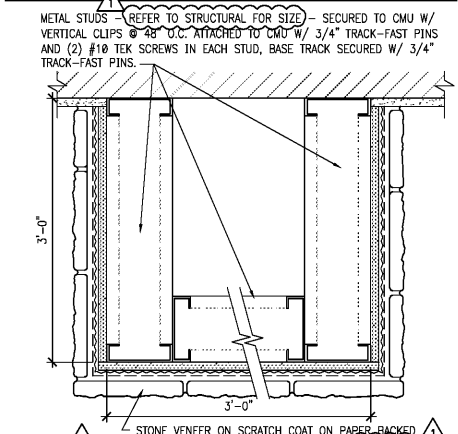

16 CORNER PILASTER BUILD-OUT 1 1/2" = 1'-0"

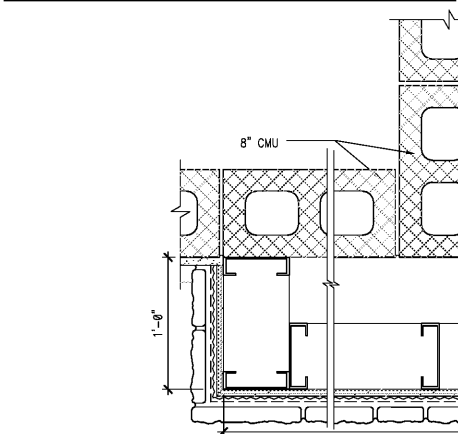

17 PILASTER BUILD-OUT 1 1/2" = 1'-0"

Order Plans @ WWW.A7DILLINE.COM