

PLANTING SCHEDULE

KEY	QNTY	BOTANICAL NAME	COMMON NAME	SIZE	COMMENTS
TREES					
AC RS	8	Acer rubrum 'Red Sunset'	Red Sunset Red Maple	3"-3.5" Cal.	B&B; matched; wrap trunk to 4ft
GL TR	9	Gleditsia triacanthos var. inermis 'Skyline'	Skyline Honey Locust	3"-3.5" Cal.	B&B; matched
LA MU	15	Lagerstroemia indica 'Muskogee'	Muskogee Crape Myrtle	10"-12" Ht	B&B; matched
LA TU	11	Lagerstroemia indica 'Tuscarora'	Tuscarora Crape Myrtle	10"-12" Ht	B&B; matched
LI ST	4	Liquidambar styraciflua	Sweetgum	3"-3.5" Cal.	B&B; matched
LI TU	6	Liriodendron tulipifera	Tulip Tree	3"-3.5" Cal.	B&B; matched
MA VI	4	Magnolia virginiana	Sweetbay Magnolia	10"-12" Ht	B&B; matched
PL OC	12	Platanus occidentalis	Sycamore	3"-3.5" Cal.	B&B; matched
QU RU	12	Quercus rubrum	Red Oak	3"-3.5" Cal.	B&B; matched
SHRUBS					
Ab eg	127	Abelia x grandiflora 'Kaleidoscope'	Kaleidoscope Abelia	30" No. 5	Cont.
Ca sa	117	Camellia sasanqua 'Yuletide'	Yuletide Camellia	24" No. 5	Cont.
Fo mt	67	Fothergilla 'MT. Airy'	Dwarf Fothergilla	24"-30" Ht	B&B
Hy pa	42	Hydrangea paniculata 'Limelight'	Hydrangea Limelight	24"-30" Ht	B&B
Ix ns	6	Ilex 'Nellie Stevens'	Nellie Stevens Holly	42"-48" Ht	B&B; matched
It vi	110	Itea virginica 'Merlot'	Merlot Sweetspire	24"-30" Ht	B&B; matched
Ph op	8	Physocarpus opulifolius	Ninebark	30"-36" Ht	B&B
Pr ol	3	Prunus laurocerasus 'Otto Luyken'	Cherry Laurel	30"-36" Ht	B&B
Rh en	67	Rhododendron x 'Robieg'	Autumn Angel Encore Azalea	24" No. 5	Cont.
Ro kn	48	Rosa x 'Knockout'	Knockout Rose	24" No. 5	Cont.
GRASSES					
cal ac	42	Calamagrostis x acutiflora 'Karl Foerster'	Feather Reed Grass	#1 Container	36" O.C
pa vi	31	Panicum virgatum	Switch Grass	#1 Container	30" O.C
pa sh	597	Panicum virgatum 'Shenandoah'	Shenandoah Switch Grass	#1 Container	24" O.C

SOD LAWN AREA = 83,279 SQ FT (1.91 ACRES)

NOTES:

STREET TREES WERE INSTALLED UNDER PREVIOUS CONTRACT.

SEE SHEET TR-1 FOR REQUIRED TREE REPLACEMENT CALCULATION.

108 TREES MUST BEER PROVIDED AS REPLACEMENT FOR TREES REMOVED
56 TREES WERE INSTALLED IN PHASE 3 (BLOCKS G AND H)
52 REQUIRED 81 TREES WILL BE INSTALLED IN PHASE 4 (BLOCKS J AND K)

GENERAL NOTES:

PRIOR TO CONSTRUCTION

- CONTRACTOR SHALL OBTAIN ALL RELEVANT DRAWINGS, DETAILS AND SPECIFICATIONS PRIOR TO BEGINNING CONSTRUCTION.
- CONTRACTOR SHALL VERIFY EXISTING FIELD CONDITIONS, REVIEW DRAWINGS AND PROPOSED WORK PRIOR TO CONSTRUCTION. ANY DISCREPANCIES SHALL BE BROUGHT TO THE ATTENTION OF THE LANDSCAPE ARCHITECT IMMEDIATELY.
- CONTRACTOR SHALL PROTECT ALL EXISTING UTILITIES AND SITE IMPROVEMENTS THAT ARE NOTED TO REMAIN AND SHALL COORDINATE TO VERIFY LOCATION OF ALL UTILITIES.

GENERAL PLANTING

- ALL PLANTS SHALL BE FURNISHED AND INSTALLED IN STRICT ACCORDANCE WITH THE 'AMERICAN STANDARD FOR NURSERY STOCK', ANSI Z60.1.1, AS PUBLISHED AND APPROVED BY THE AMERICAN ASSOCIATION OF NURSERYMEN.
- ALL TREES TO BE STAKED IN THE FIELD BY CONTRACTOR FOR APPROVAL OF LANDSCAPE ARCHITECT PRIOR TO PLANTING INSTALLATION.
- CONTRACTOR SHALL INSTALL ALL PLANT MATERIALS IN LOCATIONS AND TO DEPTHS AS SHOWN ON PLAN OR ON DETAILS. (SEE SPECIFICATIONS FOR PLANTING MIX, IF REQUIRED).
- ALL SHRUB BEDS SHALL BE MULCHED WITH SHREDDED PROCESS HARDWOOD BARK AND PINE BARK; ALL GROUNDCOVER BEDS SHALL BE MULCHED WITH MUSHROOM MANURE.
- ALL PLANT MATERIAL SHALL BE GUARANTEED FOR A PERIOD OF ONE CALENDAR YEAR AFTER WRITTEN NOTICE OF ACCEPTANCE OF ALL PLANTING WORK.

TOPSOIL

- TOPSOIL SHALL BE SUPPLIED BY THE CONTRACTOR. TOPSOIL MUST BE TESTED ACCORDING TO SPECIFICATIONS PRIOR TO ITS USE. TOPSOIL TEST RESULTS AND AMENDMENT RECOMMENDATIONS SHALL BE PROVIDED BY THE CONTRACTOR TO THE LANDSCAPE ARCHITECT PRIOR TO INSTALLATION.
- THE CONTRACTOR SHALL SUPPLY ALL PLANT MATERIALS IN QUANTITIES SUFFICIENT TO COMPLETE THE PLANTING SHOWN ON ALL DRAWINGS.
- ALL PLANTS SHALL BE BALLED AND BURLAPPED OR CONTAINER GROWN UNLESS OTHERWISE NOTED ON PLANT LIST.
- ALL PLANTS SHALL APPROVED BY THE LANDSCAPE ARCHITECT PRIOR TO OR UPON ARRIVAL ON SITE.
- ANY PROPOSED SUBSTITUTIONS OF PLANT SPECIES WILL BE MADE WITH PLANTS OF EQUIVALENT OVERALL FORM HEIGHT, BRANCHING HABIT, FLOWER, LEAF, COLOR, FRUIT, AND CULTURE ONLY AS APPROVED BY THE LANDSCAPE ARCHITECT.
- ALL AREAS DISTURBED DURING CONSTRUCTION BOTH OUTSIDE LIMITS OF WORK AND WITHIN SHALL BE SEEDDED.

IRRIGATION

- FURNISH AND INSTALL FULLY FUNCTIONING HIGH EFFICIENCY UNDERGROUND IRRIGATION SYSTEM
- INCLUDING VALVES, PIPES, TIMERS, SPRAY HEADS, CONTROLLER AND ALL NECESSARY COMPONENTS
- ACHIEVE 95% COVERAGE ON ALL PLANT AND LAWN AREAS AND PROVIDE SEPARATE ZONES FOR PLANTING VS. LAWN
- 50% OF SYSTEM MUST BE DRIP IRRIGATION TUBING TO MEET EGC STANDARDS
- PROVIDE MOISTURE SENSORS
- WATER SUPPLY SHALL BE 1" MAIN LINE AND TAP MAIN LINE OF H4 (BLOCK H) AND G4 (BLOCK G); PROVIDE DEDUCT METER, BACKFLOW PREVENTION AND VALVES IN BUILDING MECHANICAL ROOM
- GC TO PROVIDE SHOP DRAWINGS ILLUSTRATING ALL ZONES, LOCATION OF HEADS AND DRIP TUBES, VALVES AND CONTROLLER
- GC SHALL TEST AND CONFIRM OPERATION OF SYSTEM WITH OWNERS REP, TRAIN OWNERS MANAGEMENT STAFF, AND PROVIDE WARRANTY INFORMATION
- INCLUDE FIRST YEAR WINTERIZATION AND SPRING START - UP

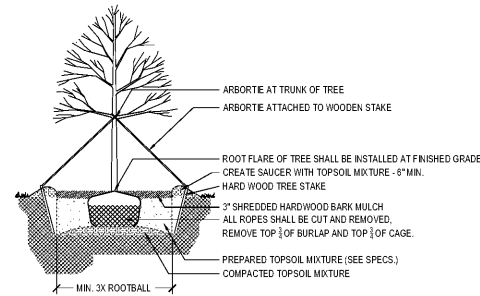

1 TYPICAL DECIDUOUS TREE PLANTING

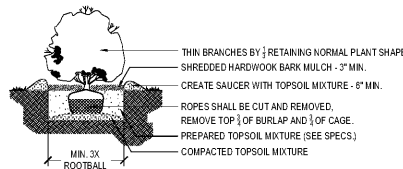

2 TYPICAL SHRUB PLANTING

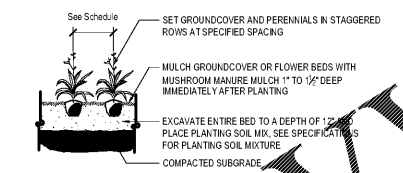

3 TYPICAL PERENNIAL/GROUNDCOVER PLANTING

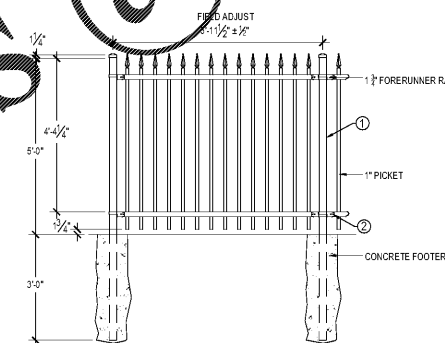

4 ORNAMENTAL ALUMINUM FENCE

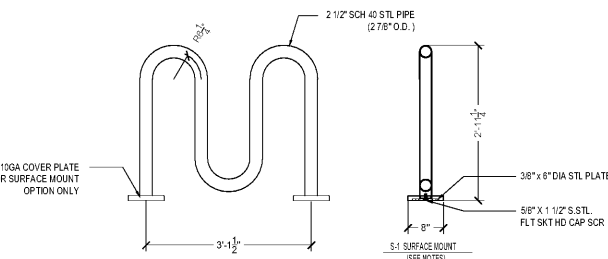

5 DuMor Bike Rack - (QTY 10)

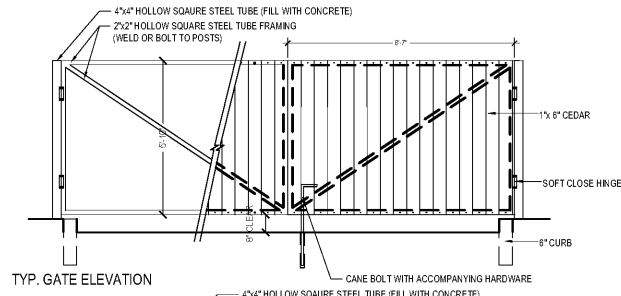

TYP. GATE ELEVATION

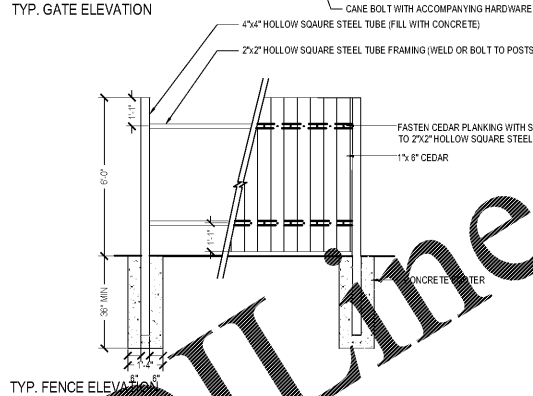

TYP. FENCE ELEVATION

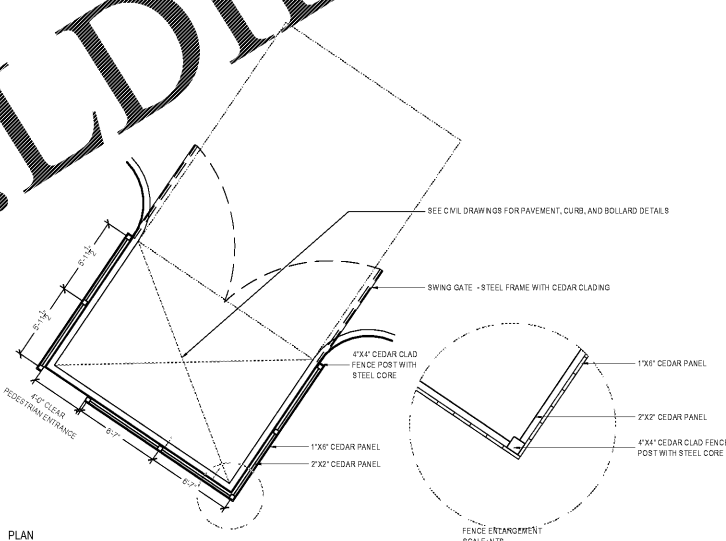

6 CEDAR TRASH ENCLOSURE - FENCE AND GATE

Order Plans @ www.LDILine.com



95 South Tenth Street
Pittsburgh, Pennsylvania 15203
tel 412. 488. 8822
fax 412. 488. 8825

Nature leads, art follows.

Client:

**McCormack
Baron
Salazar**

720 Olive St Suite 2500

St. Louis, MO 63101

Issues and Revisions

Date	Issued / Revised
3/16/2020	50% CONSTRUCTION DOCS
5/15/2020	80% CONSTRUCTION DOCS
7/13/2020	PERMIT SUBMISSION

© 2020 LaQuatra Bonci Associates
Drawings, without materials, and design concepts shall not be used or reproduced in whole or part in any form or format without prior written consent of LaQuatra Bonci Associates. Do not scale drawings. Use given dimensions only. If not shown, verify correct dimensions with the Architect. Contractor shall check and verify all dimensions and conditions at job site.

Seal

LRK Project Number: 01.15100.43

LBA Project Number: 20010

Project Name:

**South City CNI
Phase 4**

Memphis TN

Drawing Name:

Landscape Details

Drawn By: JL, ML

Checked By: JH