

These drawings are the property of Watson Tate Savory, Inc. and may not be used in whole or in part without the express consent of the architect and any subcontractor. It is subject to legal action.



ISSUE DATE: 08/24/2020
PHASE: BID SET

#	DATE	REVISION

ENLARGED PLAN
DETAILS

19-20653
STATE PROJECT NO.
NCSU #201520018
A/E PROJECT NO.
058
NCSU FACILITIES NO. SHEET

A410

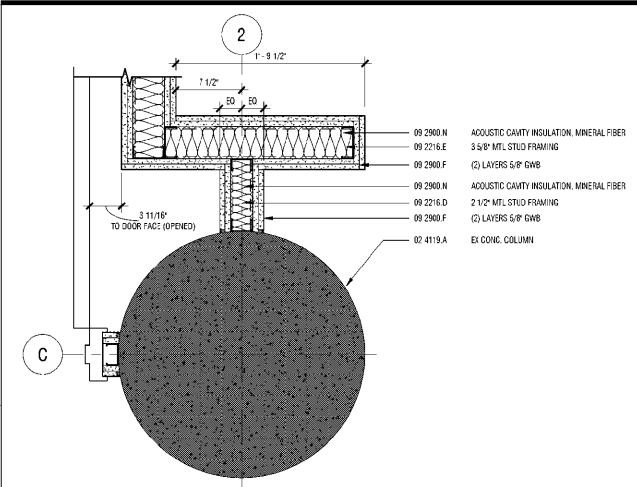

E1 ENLARGED PLAN - OFFICE COLUMN DETAIL
A410 1 1/2" = 1'-0"

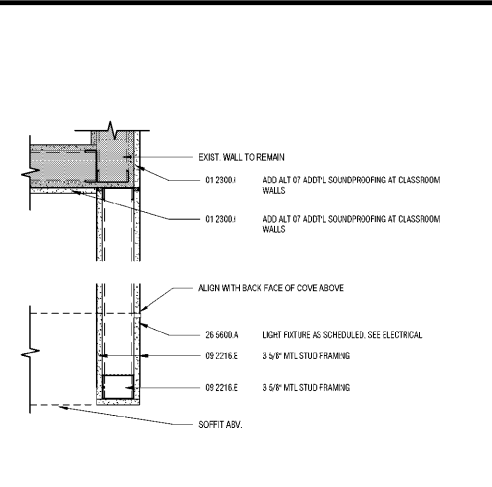

E2 PLAN DETAIL - VERTICAL LIGHT N. CORR.
A410 1 1/2" = 1'-0"

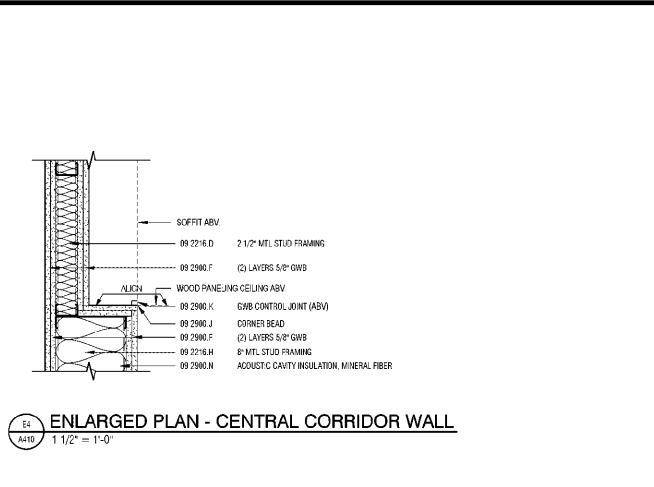

E4 ENLARGED PLAN - CENTRAL CORRIDOR WALL
A410 1 1/2" = 1'-0"

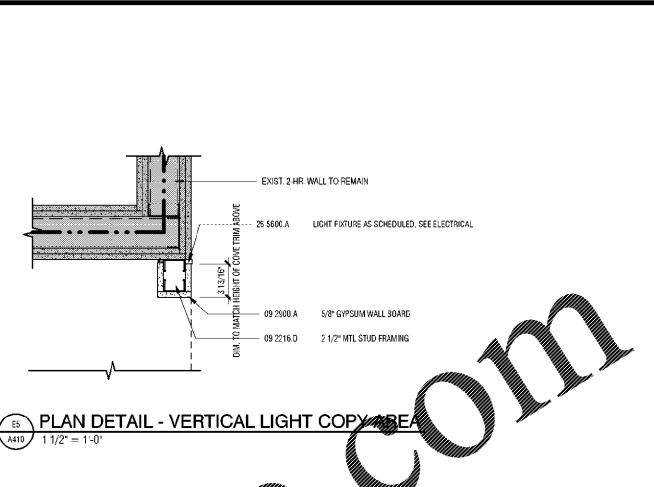

E5 PLAN DETAIL - VERTICAL LIGHT COPY AREA
A410 1 1/2" = 1'-0"

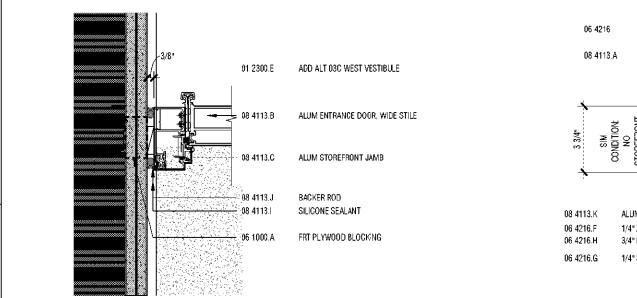

D1 JAMB DETAIL
A410 3" = 1'-0"

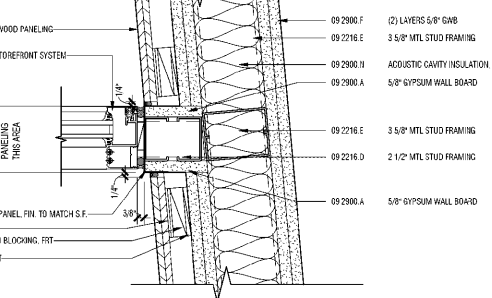

D2 JAMB DTL
A410 3" = 1'-0"

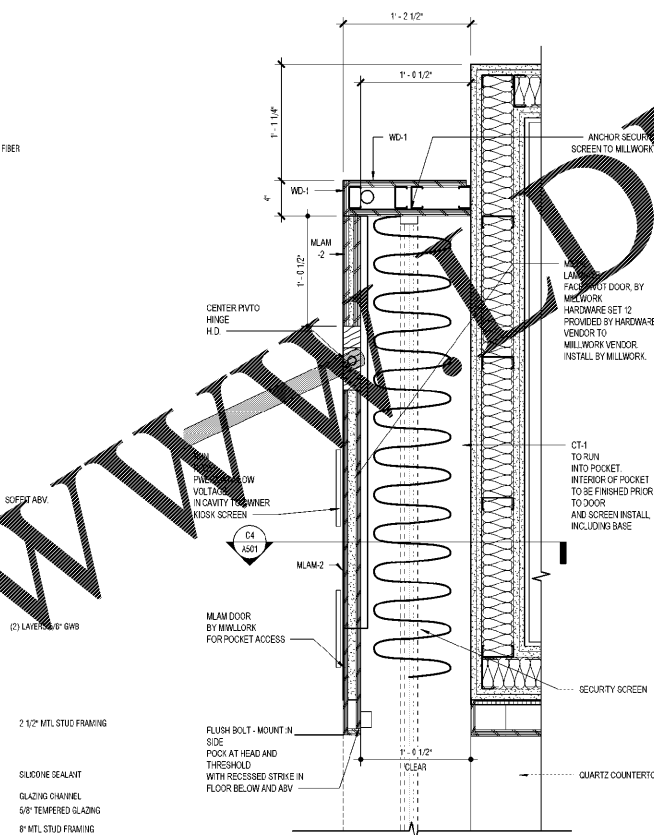

E6 ENLARGED PLAN - VESTIBULE E1101
A410 3" = 1'-0"

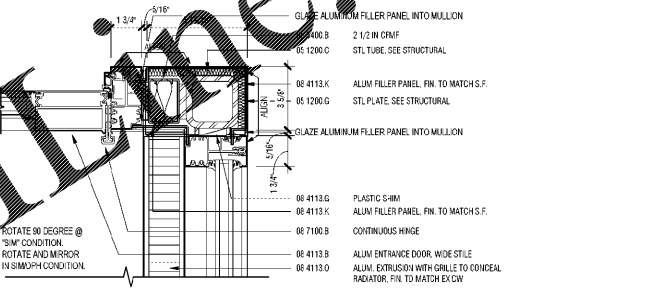

E7 ENLARGED PLAN - VESTIBULE E1101
A410 3" = 1'-0"

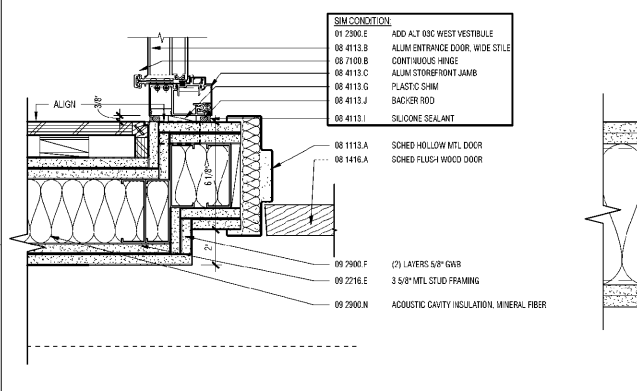

E8 ENLARGED PLAN - WOOD PANELING @ NORTH CORRIDOR
A410 3" = 1'-0"

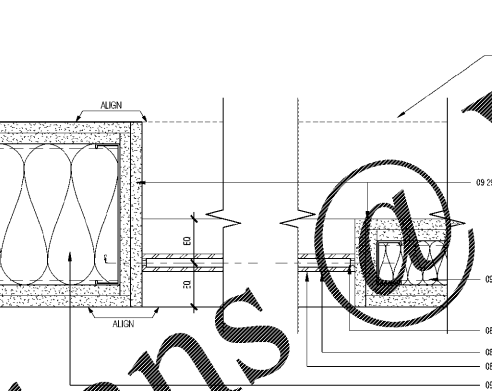

E9 ENLARGED PLAN - LIBRARY WINDOW @ STACKS
A410 3" = 1'-0"

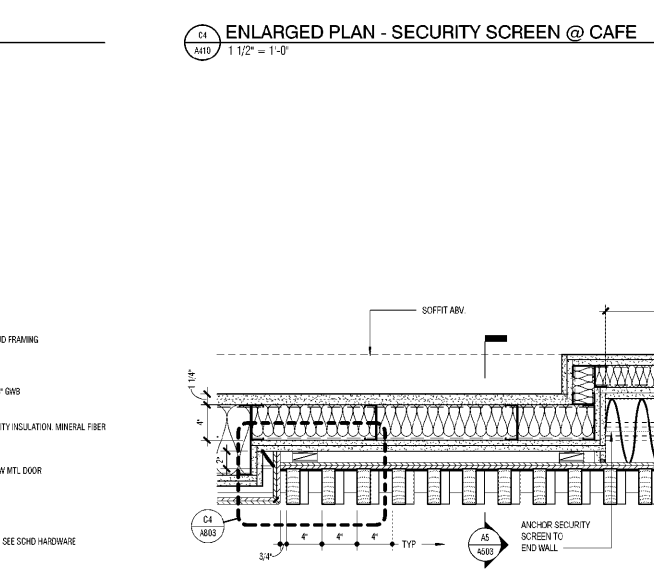

E10 ENLARGED PLAN - SECURITY SCREEN @ CAFE
A410 1 1/2" = 1'-0"

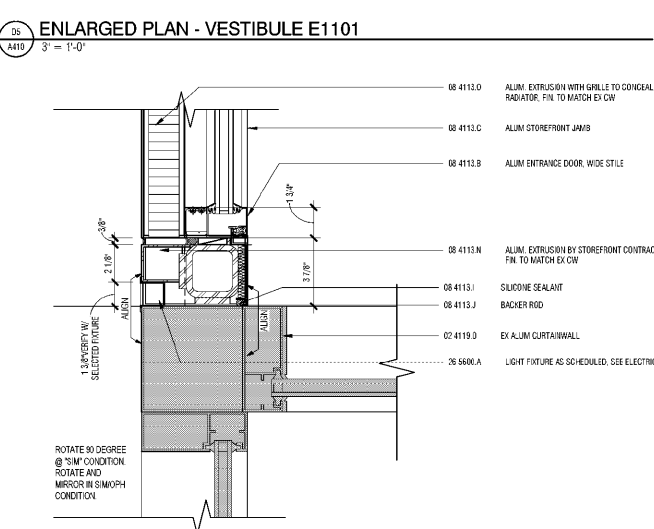

E11 ENLARGED PLAN - VESTIBULE E1101
A410 3" = 1'-0"

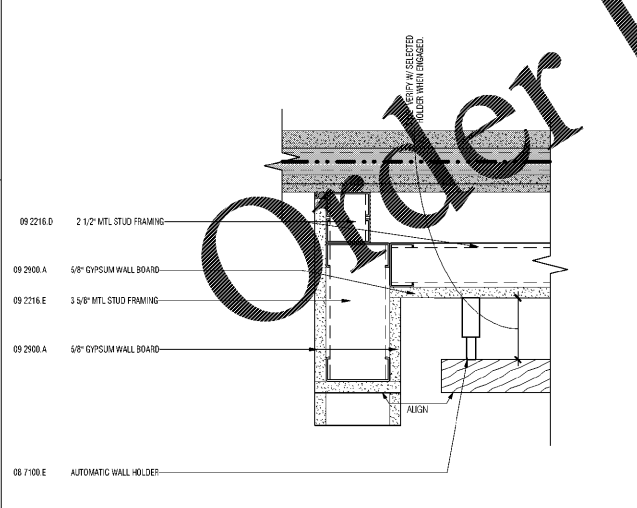

E12 ENLARGED PLAN - ADD ALT. 05
A410 3" = 1'-0"

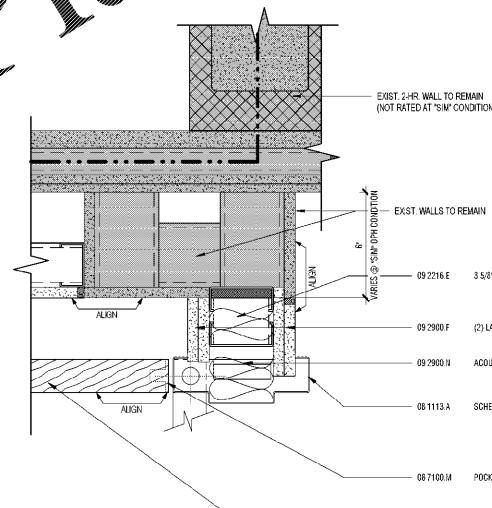

E13 ENLARGED PLAN - SECURITY SCREEN @ LIBRARY
A410 1 1/2" = 1'-0"

Order Plans @

WWW.DIEME.COM

8/21/2024 4:41:07 PM
B:\367\NCSU Jordan Hall\1911 NCSU Jordan Hall - A19.rvt