

NOTE:
SLOPES SHALL NOT EXCEED 3:1 IN STEEPNESS
UNLESS OTHERWISE NOTED ON PLANS.

1 TYPICAL TRAIL SECTION
C7.02 SCALE: NTS

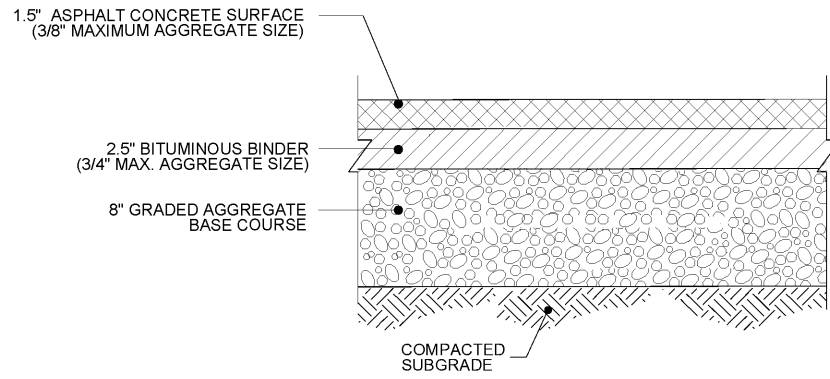

2 HEAVY DUTY ASPHALT PAVING SECTION
C7.02 SCALE: NTS

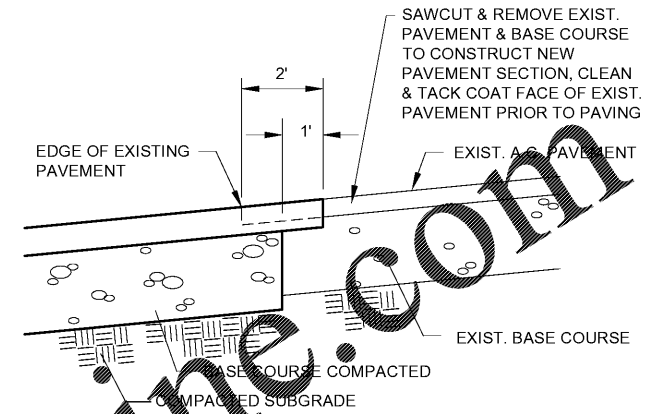

3 PAVEMENT CONNECTION
C7.02 SCALE: NTS

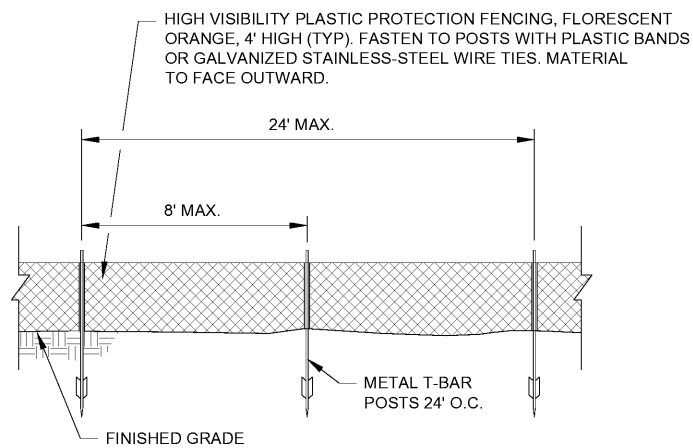

4 TREE PROTECTION FENCING DETAIL
C7.02 SCALE: NTS

WWW.LDILLINE.COM

NO.	DESCRIPTION	DATE	BY	CHK.	DATE
1	FOR YELLOW STRIPING, THE SQUARE YARDS SHOWN ON PLAN, SUMMARY AND DETAILED ESTIMATE SHEETS INCLUDE THE AREA WITHIN THE BORDERS AND THE 5" SOLID DOUBLE YELLOW BORDER.				
2	FOR WHITE STRIPING, THE SQUARE YARDS SHOWN ON PLAN, SUMMARY AND DETAILED ESTIMATE SHEETS INCLUDES THE AREA WITHIN THE BORDERS AS WELL AS THE 8" SOLID WHITE BORDER.				

DETAIL "A" (YELLOW)

DETAIL "B" (YELLOW)

DETAIL "C" (YELLOW)

DETAIL "D" (YELLOW)

DETAIL "A" (WHITE)

DETAIL "B" (WHITE)

DETAIL "C" (WHITE)

DETAIL "D" (WHITE)

GENERAL NOTES:

- FOR YELLOW STRIPING, THE SQUARE YARDS SHOWN ON PLAN, SUMMARY AND DETAILED ESTIMATE SHEETS INCLUDE THE AREA WITHIN THE BORDERS AND THE 5" SOLID DOUBLE YELLOW BORDER.
- FOR WHITE STRIPING, THE SQUARE YARDS SHOWN ON PLAN, SUMMARY AND DETAILED ESTIMATE SHEETS INCLUDES THE AREA WITHIN THE BORDERS AS WELL AS THE 8" SOLID WHITE BORDER.

GEORGIA
DEPARTMENT
OF
TRANSPORTATION

- NO SCALE -

DR.	CHK.	DATE	DESCRIPTION
AKC	JBS	05/07/2020	100% OWNER REVIEW
B	AKC	06/15/2020	DRAFT BID PACKAGE
C	AKC	07/14/2020	BID PACKAGE

STATE OF GEORGIA
DEPARTMENT OF TRANSPORTATION
OFFICE OF TRAFFIC OPERATIONS
SIGNING AND MARKING PLANS

DATE: 6/25/04
REVISIONS:
11/28/05
11/21/08

DETAIL OF PAVEMENT MARKING
MATCHING
JANUARY 2000

SCALE: T-14

REV.	DR.	CHK.	DATE	DESCRIPTION
A	AKC	JBS	05/07/2020	100% OWNER REVIEW
B	AKC	JBS	06/15/2020	DRAFT BID PACKAGE
C	AKC	JBS	07/14/2020	BID PACKAGE