

## MARRIOTT SAWGRASS CABANA CLUB

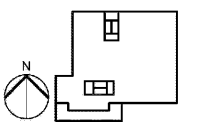

REVISION NO.	DESCRIPTION	DATE

HKS PROJECT NUMBER  
**22808.001**  
DATE:  
**05/22/2020**  
ISSUE:  
**PERMIT SET**

SHEET TITLE  
**DETAILS -  
PLUMBING/FP**

SHEET NO.  
**P5.01**

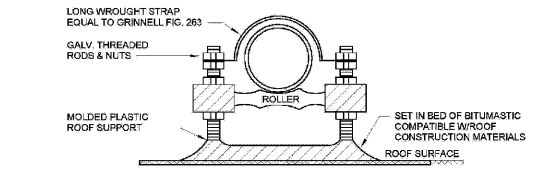

**9** DETAIL - ROOF PIPE SUPPORT W/ ROLLER  
P5.01 N.T.S.

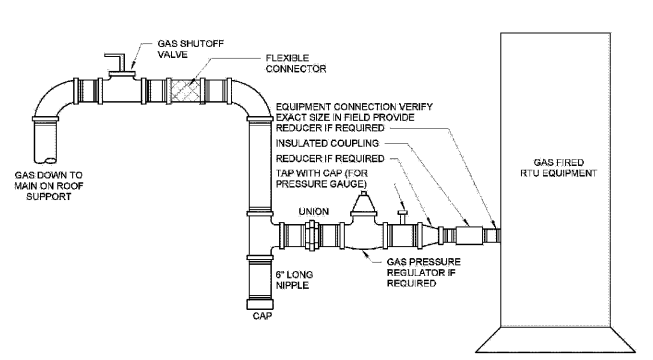

**6** DETAIL - EXTERIOR GAS FIRED EQUIPMENT CONNECTION  
P5.01 N.T.S.

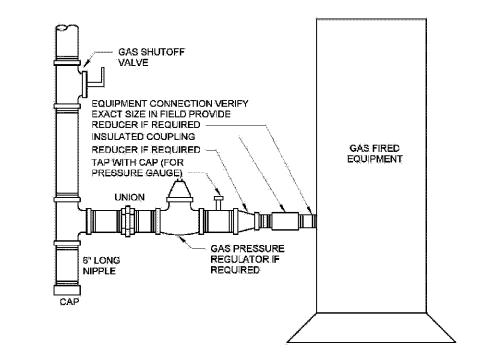

**3** DETAIL - GAS FIRED EQUIPMENT CONNECTION  
P5.01 N.T.S.

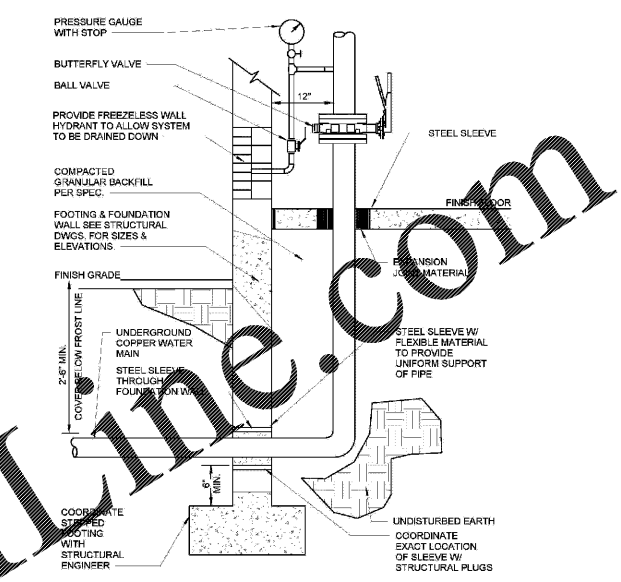

**1** DETAIL - WATER SERVICE ENTRANCE RISER  
P5.01 N.T.S.

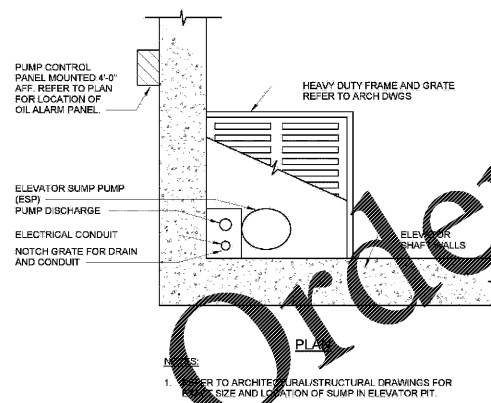
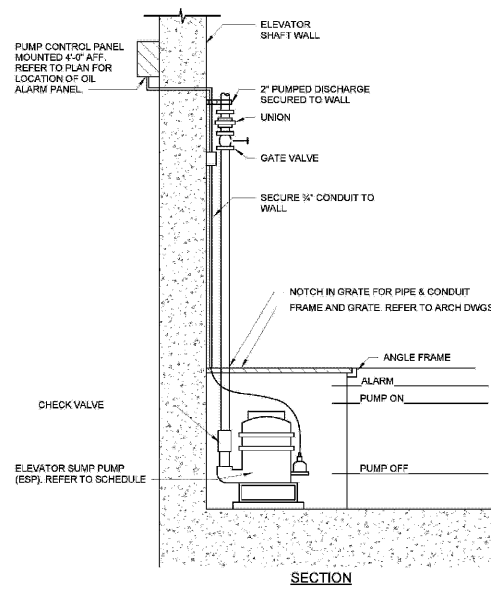

**10** DETAIL - ELEVATOR SUMP PUMP (ESP)  
P5.01 N.T.S.

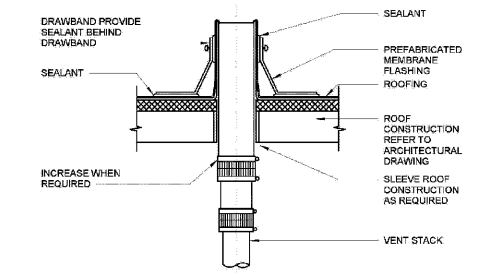

**7** DETAIL - VENT THROUGH ROOF (VTR)  
P5.01 N.T.S.

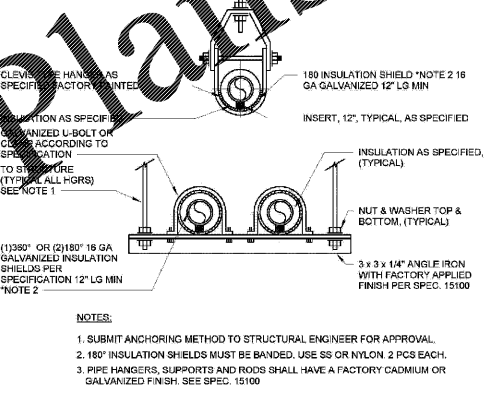
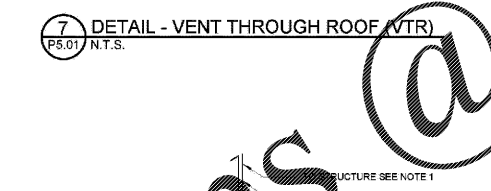

**8** DETAIL - PIPE HANGER  
P5.01 N.T.S.

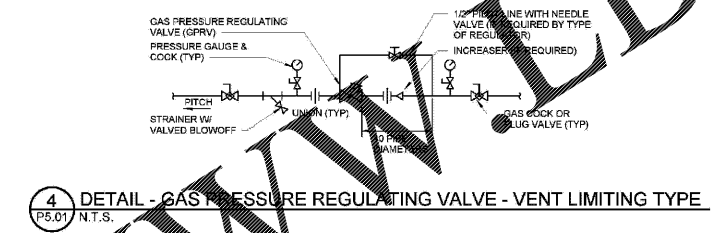

**4** DETAIL - GAS PRESSURE REGULATING VALVE - VENT LIMITING TYPE  
P5.01 N.T.S.

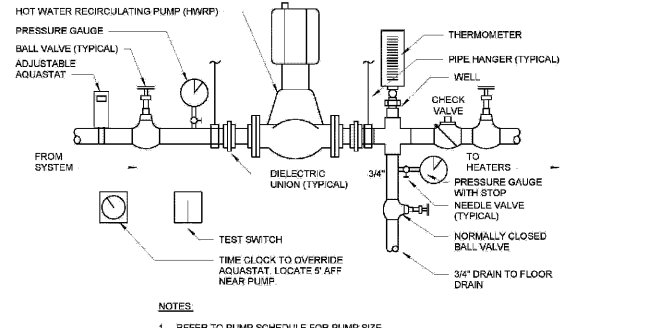
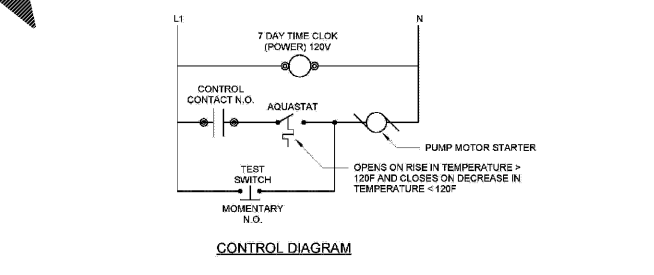

**5** DETAIL - HOT WATER RECIRCULATING PUMP (HWRP)  
P5.01 N.T.S.

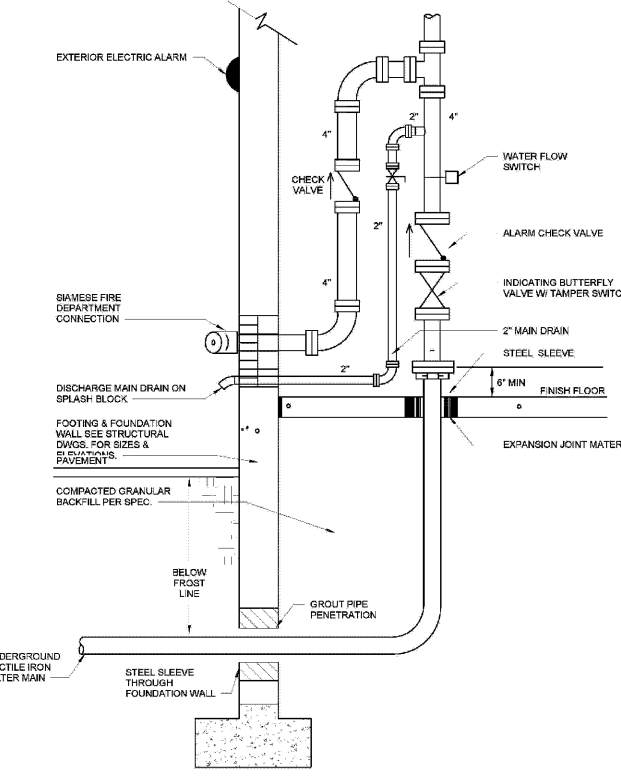

**2** DETAIL - FIRE PROTECTION SERVICE ENTRANCE  
P5.01 N.T.S.

*Order plans @*

*WWW.DIYline.com*