

MARRIOTT SAWGRASS CABANA CLUB

OWNER
WATERMARK CAPITAL PARTNERS, LLC
150 NORTH RIVERBIDE PLAZA SUITE 400
CHICAGO, IL 60606

OWNER'S CONSULTANT
THE JOHN HARDY GROUP INC.
6355 SHARFIELD RD. SUITE 200
ATLANTA, GA 30328



DESIGN WAREHOUSE STATE OF FLORIDA REGISTERED ENGINEER NO. 55303
THIS DRAWING BEING A DESIGN OR PART OF A DESIGN OF STRUCTURAL WORK
FOR WHICH I AM A LICENSED PROFESSIONAL ENGINEER IN THE STATE OF FLORIDA
I HEREBY CERTIFY THAT I AM THE DESIGNER OF THIS DRAWING OR PART THEREOF
AND THAT I AM NOT PROVIDING ANY ELECTRICAL SERVICE

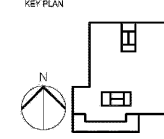

REVISION NO.	DESCRIPTION	DATE

HKS PROJECT NUMBER
22808.001
DATE:
05/22/2020
ISSUE:
PERMIT SET

SHEET TITLE
CONCRETE COLUMN SCHEDULE AND TYPICAL DETAILS
S4.01

f_c = SEE GENERAL NOTES

LEVEL	C1	C2	C3	C4	C5	C6	C7	C8	C9	C10	C11	C12	C13	C14	C15	C16
ROOF DECK LEVEL	10X10 4 #6 T A #5 @ 8"	10X10 4 #6 T A #5 @ 8"	8X10 4 #6 T B #5 @ 8"	8X10 4 #6 T B #5 @ 8"	8X10 4 #6 T B #5 @ 8"	8X10 4 #6 T B #5 @ 8"	8X10 4 #6 T B #5 @ 8"	8X10 4 #6 T B #5 @ 8"	8X10 4 #6 T B #5 @ 8"	8X10 4 #6 T B #5 @ 8"	8X10 4 #6 T B #5 @ 8"	8X10 4 #6 T B #5 @ 8"	8X10 4 #6 T B #5 @ 8"	8X10 4 #6 T B #5 @ 8"	8X10 4 #6 T B #5 @ 8"	8X10 4 #6 T B #5 @ 8"
2nd FLOOR	10X10 4 #6 T A #5 @ 8"	10X10 4 #6 T A #5 @ 8"	8X10 4 #6 T B #5 @ 8"	8X10 4 #6 T B #5 @ 8"	8X10 4 #6 T B #5 @ 8"	8X10 4 #6 T B #5 @ 8"	8X10 4 #6 T B #5 @ 8"	8X10 4 #6 T B #5 @ 8"	8X10 4 #6 T B #5 @ 8"	8X10 4 #6 T B #5 @ 8"	8X10 4 #6 T B #5 @ 8"	8X10 4 #6 T B #5 @ 8"	8X10 4 #6 T B #5 @ 8"	8X10 4 #6 T B #5 @ 8"	8X10 4 #6 T B #5 @ 8"	8X10 4 #6 T B #5 @ 8"
1st FLOOR	10X10 4 #6 T A #5 @ 8"	10X10 4 #6 T A #5 @ 8"	8X10 4 #6 T B #5 @ 8"	8X10 4 #6 T B #5 @ 8"	8X10 4 #6 T B #5 @ 8"	8X10 4 #6 T B #5 @ 8"	8X10 4 #6 T B #5 @ 8"	8X10 4 #6 T B #5 @ 8"	8X10 4 #6 T B #5 @ 8"	8X10 4 #6 T B #5 @ 8"	8X10 4 #6 T B #5 @ 8"	8X10 4 #6 T B #5 @ 8"	8X10 4 #6 T B #5 @ 8"	8X10 4 #6 T B #5 @ 8"	8X10 4 #6 T B #5 @ 8"	8X10 4 #6 T B #5 @ 8"
DOWELS	4 #8 T	6 #8 T	4 #8 T	6 #8 T	6 #8 T	6 #8 T	6 #8 T	6 #8 T	6 #8 T	6 #8 T	6 #8 T	6 #8 T	6 #8 T	6 #8 T	6 #8 T	6 #8 T
COLUMN MARK	C1	C2	C3	C4	C5	C6	C7	C8	C9	C10	C11	C12	C13	C14	C15	C16

- COLUMN NOTES:**
- FOR TOP OF STRUCTURAL SLAB ELEVATIONS SEE PLAN
 - PROVIDE TENSION LAP SPICE AT ALL VERTICAL BARS UNLESS OTHERWISE NOTED. SEE COLUMN LAP SPICE SCHEDULE FOR SPICE LENGTH.
 - PROVIDE #3 @ 8" TIES UNLESS OTHERWISE NOTED. TIE SPACING IS NOT TO EXCEED LEAST COLUMN DIMENSION OR 16 VERTICAL BARS.
 - COLUMN SIZES SHOWN ARE PLAN DIMENSIONS IN INCHES FOR COLUMN ORIENTATION SEE PLAN.
 - WHERE SCHEDULED INFORMATION IS NOT SHOWN SEE FLOOR BELOW.

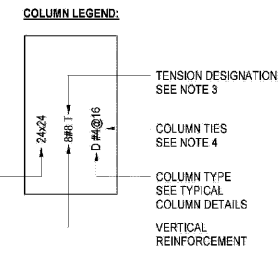

1 CONCRETE COLUMN SCHEDULE

NOT TO SCALE

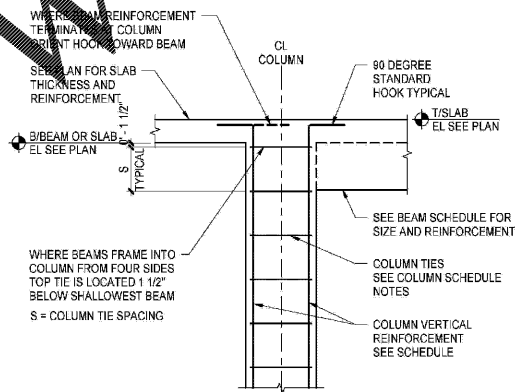

3 TYPICAL TOP OF COLUMN

NOT TO SCALE

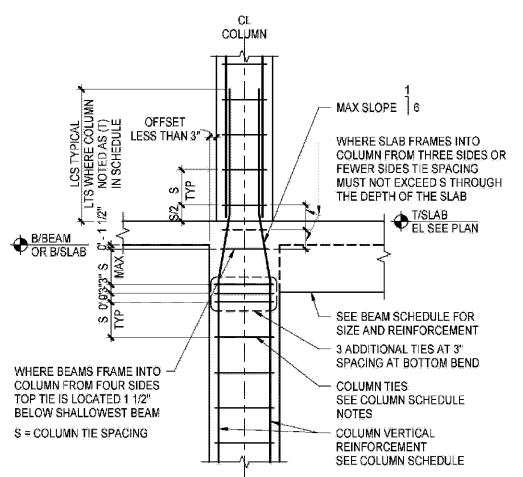

5 TYPICAL COLUMN OFFSET LESS THAN 3"

NOT TO SCALE

4 TYPICAL COLUMN OVERPOUR TOLERANCE

NOT TO SCALE

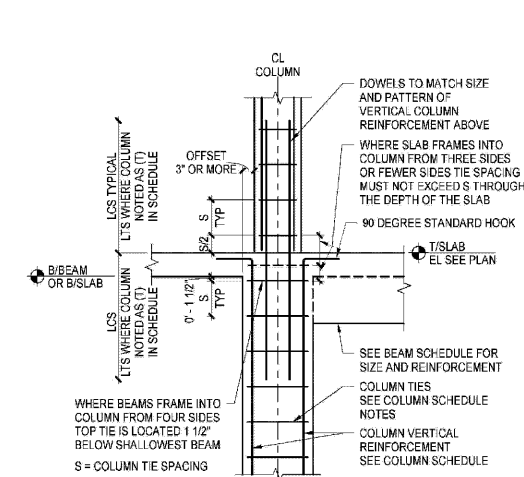

6 TYPICAL COLUMN OFFSET 3" OR MORE

NOT TO SCALE

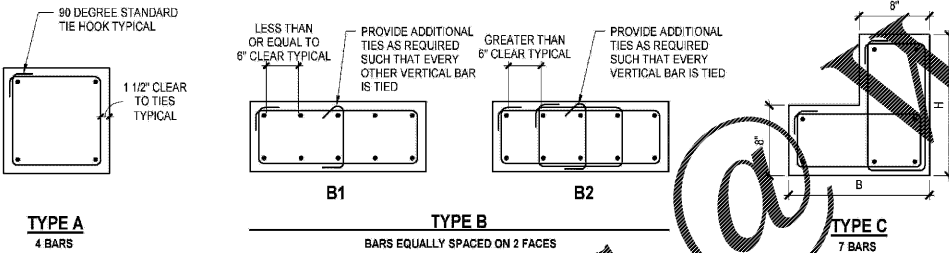

- NOTES:**
- FOR ALL TYPES STAGGER ALL TIE HOOKS
 - FOR TYPE B TOTAL NUMBER OF BARS SHOULD BE SPACED AROUND PERIMETER SUCH AS TO ACHIEVE EQUAL SPACING ON THE TWO LONG SIDES

2 COLUMN TYPES - BAR ARRANGEMENT

NOT TO SCALE

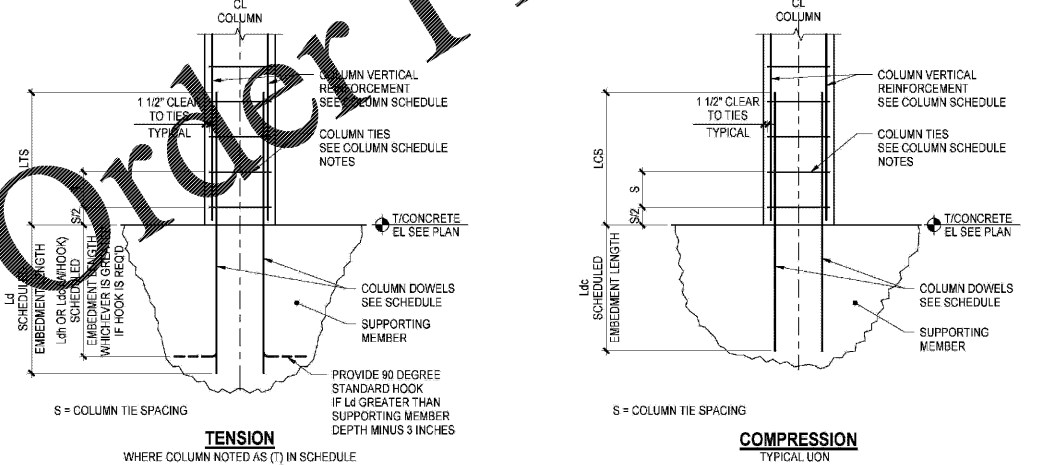

7 TYPICAL BOTTOM OF COLUMN

NOT TO SCALE

BM 130 122903.07_Marricott Sawgrass Column Club_201905_MARRIOTT_CABANA_CLUB_2019.rvt
 BM 130 122903.00_Marricott Sawgrass Column Club_201905_MARRIOTT_CABANA_CLUB_2019.rvt
 Sheet Number: S4.01
 © THORNTON TOMASETTI, INC. 2020 PLOTTED ON: 5/21/2020 5:24:46 PM
 TEMPLATE VERSION: 5.00 20170223