

MARRIOTT SAWGRASS CABANA CLUB

619 PONTE VEDRA BLVD
PONTE VEDRA BEACH, FL 32082

OWNER
WATERMARK CAPITAL PARTNERS, LLC
150 NORTH RIVERSIDE PLAZA SUITE 4000
CHICAGO, IL 60606

OWNER'S CONSULTANT
THE JOHN HENRY GROUP INC.
6085 BARKFIELD RD. SUITE 300
ATLANTA, GA 30328

CIVIL ENGINEER AND LANDSCAPE CONSULTANT
HOLEVIAHORN
12740 GRAN BAY PARKWAY WEST
SUITE 2050
JACKSONVILLE, FL 32256

INTERIOR DESIGN CONSULTANT
H&A DESIGN
3215 NEBRASKA AVENUE, SANTA MONICA,
CALIFORNIA 90404 U. S. A.

This drawing is for information only to be used by the contractor as a general arrangement of error conditions. It has been made from available information. However, measurements are to be verified on project site. This drawing must be verified and approved prior to their detailing and fabrication.
This drawing is the property of HKS ARCHITECTS, INC. and is not to be reproduced or copied in whole or in part. It is only to be used for the project and site specifically identified herein and is not to be used on any other project. It is to be returned upon request.

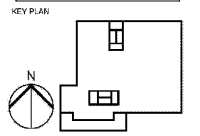

REVISION NO.	DESCRIPTION	DATE

HKS PROJECT NUMBER

22808.001

DATE

05/22/2020

ISSUE

PERMIT SET

SHEET TITLE
**PUBLIC AREA - LEVEL 1
ELEVATION**

SHEET NO.

IE1.02

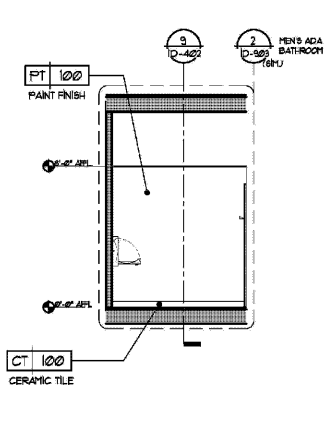

21 ELEVATION
Scale: 1/4" = 1'-0"

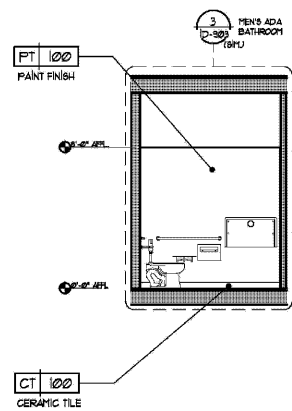

22 ELEVATION
Scale: 1/4" = 1'-0"

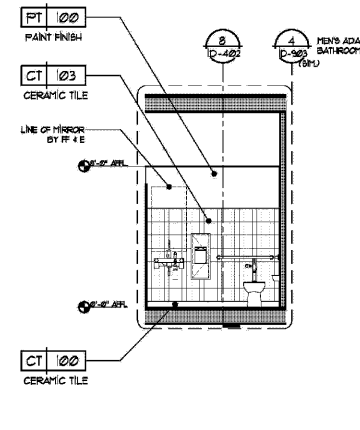

23 ELEVATION
Scale: 1/4" = 1'-0"

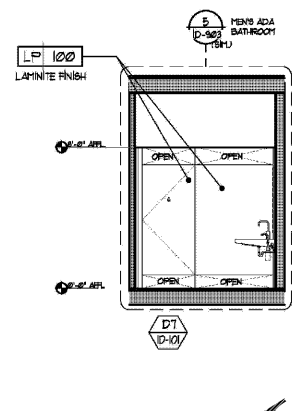

24 ELEVATION
Scale: 1/4" = 1'-0"

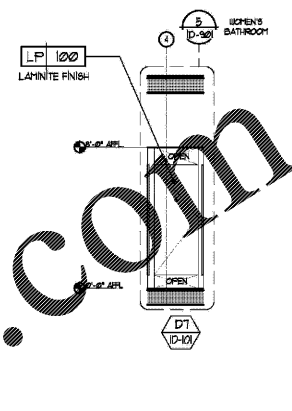

25 ELEVATION
Scale: 1/4" = 1'-0"

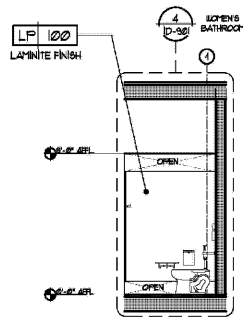

26 ELEVATION
Scale: 1/4" = 1'-0"

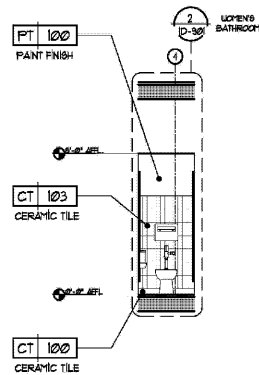

27 ELEVATION
Scale: 1/4" = 1'-0"

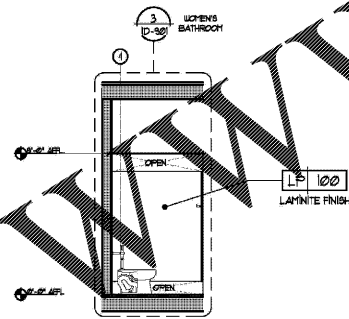

28 ELEVATION
Scale: 1/4" = 1'-0"

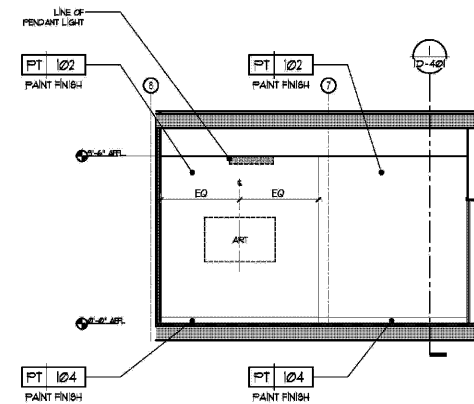

29 ELEVATION @ VESTIBULE
Scale: 1/4" = 1'-0"

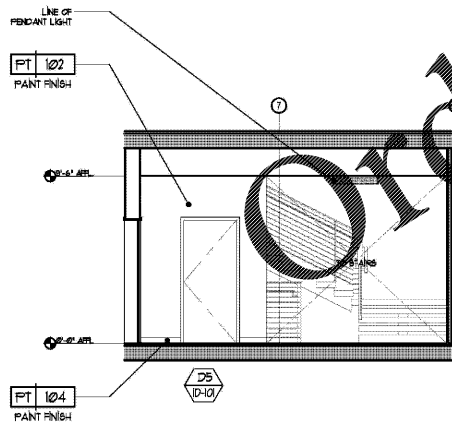

30 ELEVATION
Scale: 1/4" = 1'-0"

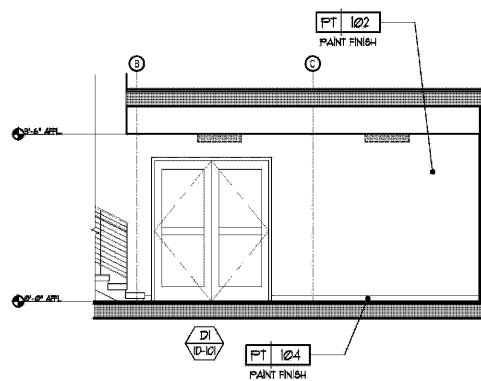

31 ELEVATION
Scale: 1/4" = 1'-0"

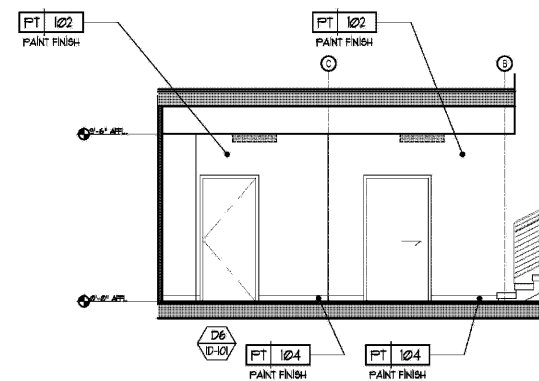

32 ELEVATION
Scale: 1/4" = 1'-0"