

24-HOUR EMERGENCY CONTACT
WAYNE CHANNER
DCSD SPOST V CIP PROGRAM
SENIOR PROJECT MANAGER
CELL: (404) 924-5628

PROJECT CONTACTS

OWNER/DEVELOPER:
 DEKALB COUNTY BOARD OF EDUCATION
 1705 MOUNTAIN INDUSTRIAL BLVD.
 STONE MOUNTAIN, GA 30088
 CONTACT: WAYNE CHANNER
 PHONE: (404) 924-5628

ARCHITECT:
 STANLEY LOVE STANLEY P & C
 2685 SPRING ST. N.W.
 ATLANTA, GA 30309-3818
 CONTACT: WAYNE CHANNER
 PHONE: (404) 876-3003

SITE DESIGN PROFESSIONAL:
 BRIDGECREST LAND PLANNING, INC.
 25 BOWEN RD.
 ATLANTA, GA 30308
 CONTACT: CHRIS BRIDGECREST
 PHONE: (770) 483-1173

TOPOGRAPHIC SURVEY PREPARED BY:
 GORHAM, LTD.
 2300 MARSH MOUNTAIN RD.
 MARIETTA, GA 30067
 PHONE: (770) 428-2228
 FAX: (770) 428-2228
JOB No. 141

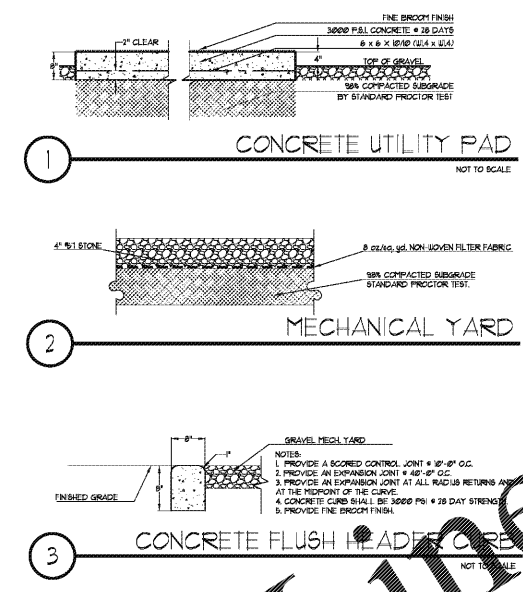

DI
 TOP 1020.16
 IN(A) 1014.9
 IN(B) 1015.3
 OUT 1014.8

15" CAMP

TBM
 MAG NAIL
 NORTH: 1,385,899.61
 EAST: 2,278,374.64
 ELEV: 1020.88

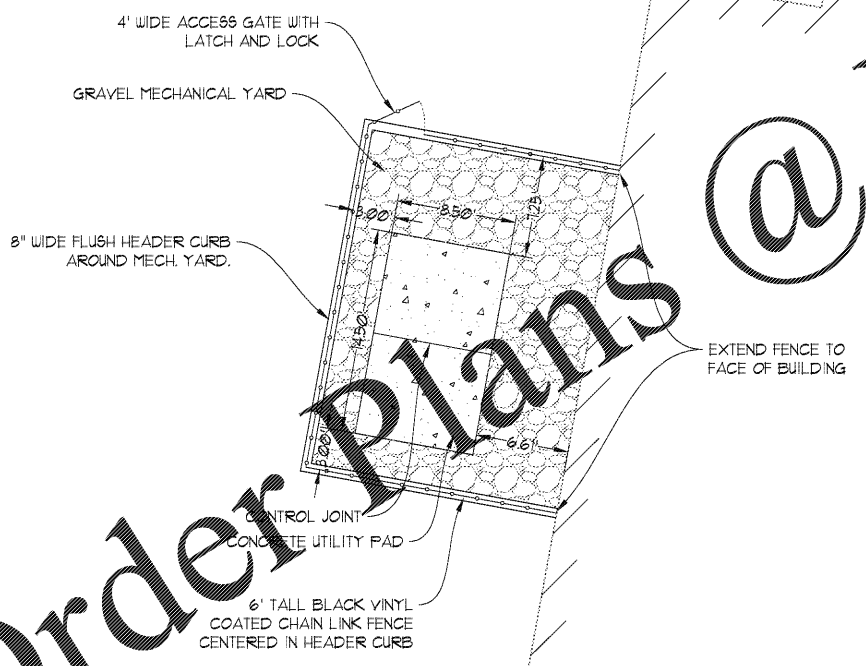
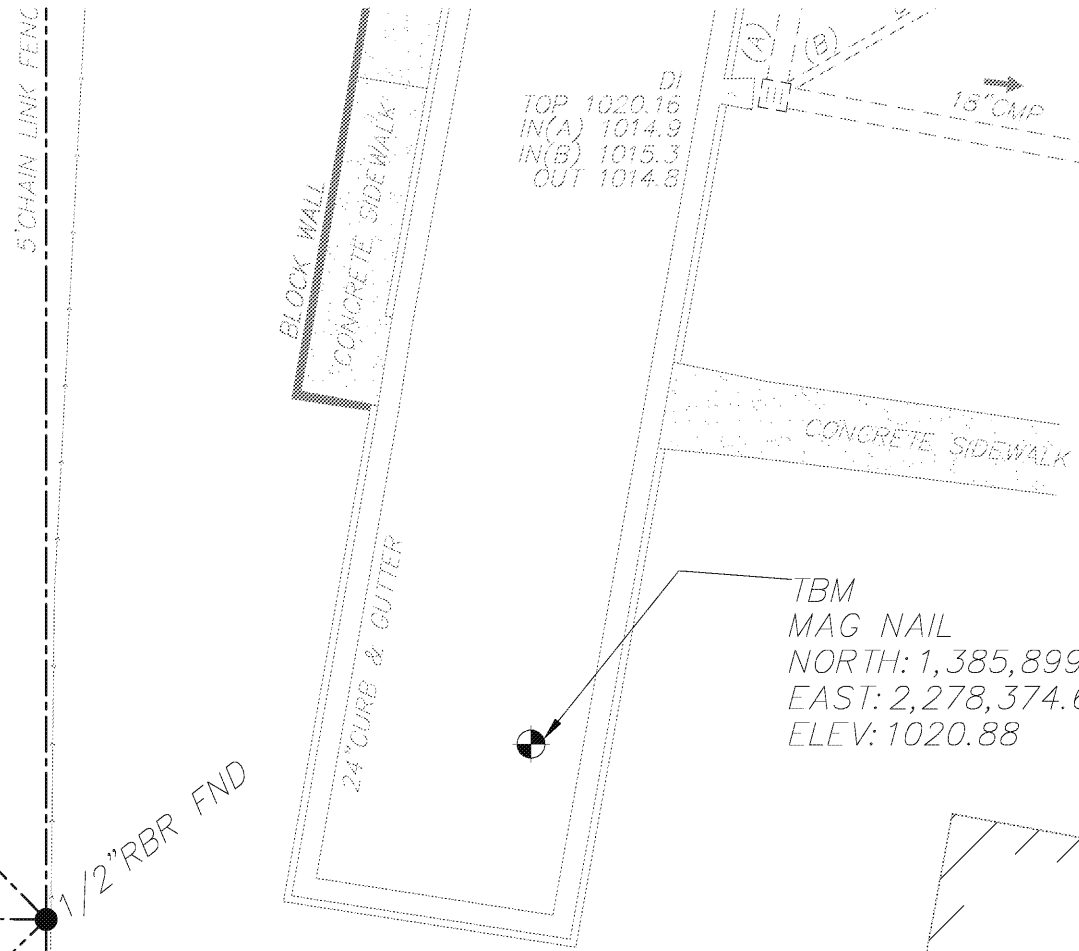

EXACT LOCATION OF CONCRETE PAD SHALL BE COORDINATED WITH MECHANICAL EQUIPMENT. MECHANICAL EQUIPMENT MUST MAINTAIN, AT A MINIMUM, THE CLEARANCES SHOWN ON THE M/E/P DRAWINGS

Order Plans @

1 STORY GYMNASIUM BLOCK BUILDING

FFE=1020.1'

5' CHAIN LINK FENCE
 PER TAX MAP
 1/2" RBR FND
 XIMATE BOUNDARY LINES PER TAX MAP

Order Plans @

WWW.LDILINE.COM

JOLLY ES GYM HVAC DESIGN
 1070 Otello Ave, Clarkston, GA 30021



ARCHITECTURE
 INTERIORS PLANNING
 PROGRAM MANAGEMENT

1508 SPRING STREET, N.W.
 ATLANTA, GEORGIA 30309-3818
 404-876-3000
 404-876-3003 FAX
 www.stanleylove-stanley.com

DRAWING TITLE
 LAYOUT & PAVING PLAN
 AND DETAILS



CONTRACTOR

LAYOUT PLAN NOTES

1. PROPOSED USE: ELEMENTARY SCHOOL.
2. CONTRACTOR SHALL VERIFY CONDITIONS AND DIMENSIONS BEFORE PROCEEDING WITH CONSTRUCTION. ANY DISCREPANCIES FOUND SHALL BE REPORTED TO THE ARCHITECT FOR CLARIFICATION AND/OR CORRECTION BEFORE PROCEEDING WITH THE WORK. CONTRACTOR SHALL ASSUME RESPONSIBILITY FOR DISCREPANCIES WHICH ARE NOT REPORTED.
3. ALL DIMENSIONS ARE TO THE FACE OF CURBS AND FACE OF WALLS.
4. ALL ANGLES ARE 90° UNLESS OTHERWISE NOTED.

DO NOT BREAK OR DUPLICATE

1. DO NOT DUPLICATE DRAWINGS WITHOUT PERMISSION.
2. READ THE SPECIFICATIONS, THIS SET OF DRAWINGS AND SPECIFICATIONS DEFINE PROJECT SCOPE AND CONTRACT REQUIREMENTS. INDIVIDUAL SHEETS REMOVED FROM THE SET MAY NOT ADEQUATELY REFLECT ALL INFORMATION NEEDED TO SUITABLY COVER CERTAIN ITEMS. DO NOT SEPARATE THIS SET OF DRAWINGS INTO INDIVIDUAL SHEETS.

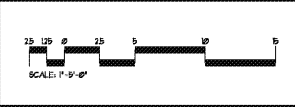

CAUTION

THE UTILITIES SHOWN ARE SHOWN FOR THE CONTRACTOR'S CONVENIENCE ONLY. THERE MAY BE OTHER UTILITIES NOT SHOWN ON THESE PLANS. THE DESIGN PROFESSIONAL ASSUMES NO RESPONSIBILITY FOR THE LOCATIONS SHOWN AND IT SHALL BE THE CONTRACTOR'S RESPONSIBILITY TO VERIFY THE LOCATIONS OF UTILITIES WITHIN THE LIMITS OF THE WORK. DAMAGE TO EXISTING UTILITIES BY THE CONTRACTOR FROM HIS/HER OPERATIONS, SHALL BE THE SOLE RESPONSIBILITY OF THE CONTRACTOR.

811 Know what's below. Call before you dig. Dial 811 Or Call 800-282-7411

CONTRACTOR SHALL BE RESPONSIBLE TO SECURE THE SERVICES OF A PRIVATE UTILITY LOCATOR FIRST DURING THE ENTIRE COURSE OF CONSTRUCTION. CONTRACTOR SHALL PAY FOR SAID SERVICES. CONTRACTOR SHALL IMMEDIATELY REPAIR ALL UTILITIES DAMAGED BY CONSTRUCTION ACTIVITIES AT NO ADDITIONAL COST TO THE OWNER.

CONTRACTOR SHALL BE RESPONSIBLE FOR PROTECTION OF BACKFILL OF ALL UTILITY TRENCHES WITHIN SITE WORK LIMITS. THIS INCLUDES TRENCHES DUG AND BACKFILLED BY LOCAL UTILITIES SUCH AS POWER, GAS, TELEPHONE, ETC. CONTRACTOR SHALL PROVIDE ADDITIONAL BACKFILL AND PROTECTION AS NECESSARY IF SETTLEMENT OCCURS.

SCALE AS STATED HEREON ARE VALID ON THE ORIGINAL DRAWING. THE DIMENSIONS OF WHICH ARE SHOWN ON THE BOARD. IF A SCALE IS SHOWN ON THE BOARD, IT SHALL BE USED FOR THE ENTIRE PROJECT AND IS NOT TO BE USED ON ANY OTHER PROJECT. IT IS TO BE RETURNED UPON REQUEST.

THIS DRAWING IS THE PROPERTY OF STANLEY LOVE STANLEY P & C. IT IS NOT TO BE REPRODUCED OR COPIED IN WHOLE OR IN PART, IF A SCALE IS SHOWN ON THE BOARD, IT SHALL BE USED FOR THE ENTIRE PROJECT AND IS NOT TO BE USED ON ANY OTHER PROJECT. IT IS TO BE RETURNED UPON REQUEST.

COPYRIGHT © 2016. ALL RIGHTS RESERVED BY STANLEY LOVE STANLEY P & C.

DRAWING NO.
 DATE
 September 09, 2019
 PROJECT NO.
 6919.3
 DRAWING NO.

C200

Project Issue Date: 12/09/19
 RELEASED FOR CONSTRUCTION