

ENGINEER OF RECORD
RYAN S. JONES
 ENGINEER LICENSE NUMBER
 047828
 SHEETS BEARING THIS SEAL ARE
 AUTHENTICATED. RESPONSIBILITY FOR
 ALL OTHER PLANS, SPECIFICATIONS
 OR INSTRUMENTS ARE DISCLAIMED.

CJD
 Engineering | Energy | Innovation
 2225 West Chesapeake Boulevard, Suite 200, Springfield, MO 65807
 P: 417.877.1700
 www.cjd-eng.com

PROJECT:
NEW O'REILLY AUTO PARTS STORE
2801 SOUTH MIAMI BLVD.
DURHAM, NC 27703

O'Reilly AUTO PARTS
 CORPORATE OFFICES
 233 SOUTH PATTERSON
 SPRINGFIELD, MISSOURI 65802
 (417) 882-2674 TELEPHONE

DRAWN BY: **JBR** CHECKED BY: **CRF**
 DATE: **12/20/19**
 REVISION:
 PROJECT NUMBER:
19261-DC1
 SHEET NUMBER

P2

PLUMBING CALCULATIONS

FIXTURE	QUANTITY	TOTAL-SFU	TOTAL	TOTAL-HW	TOTAL	DFU	TOTAL
W.C. (TANK)	2	5	10	0	0	4	8
URN. (URINAL)	1	5	5	0	0	4	4
LAV. (LAVATORY)	2	2	4	1.5	3.00	2	4
M.B. (MOP BASIN)	1	3	3	1.5	1.50	2	2
H.D.F. (FOUNTAIN)	1	0.25	0.25	0	0	0.5	0.50
H.B. (HOSE BIBB)	2	3	6	0	0	0	0
TOTAL		28.25	TOTAL	4.50	TOTAL	18.50	
TOTAL CW GPM	20	AVERAGE DAILY FLOW = 125 gal/DAY					
COLD WATER SERVICE SIZE	1"						

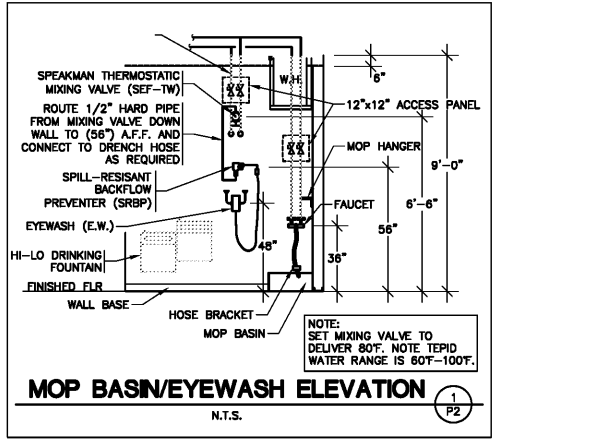
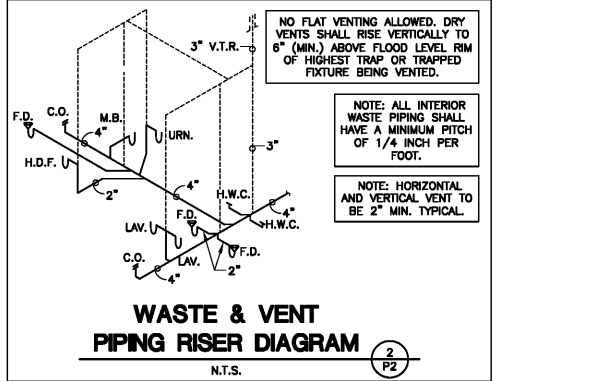
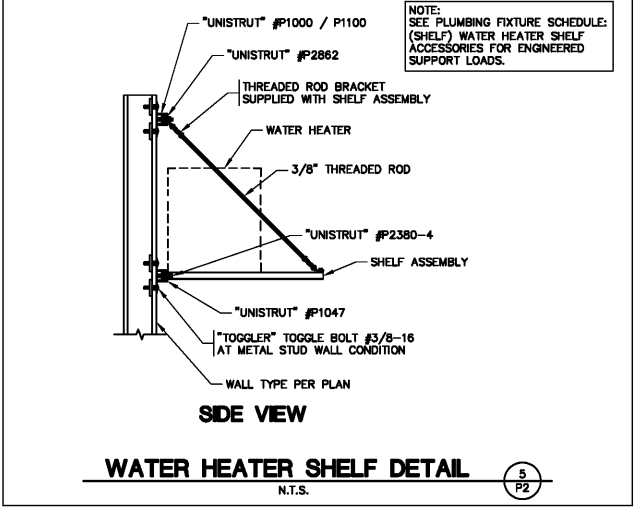
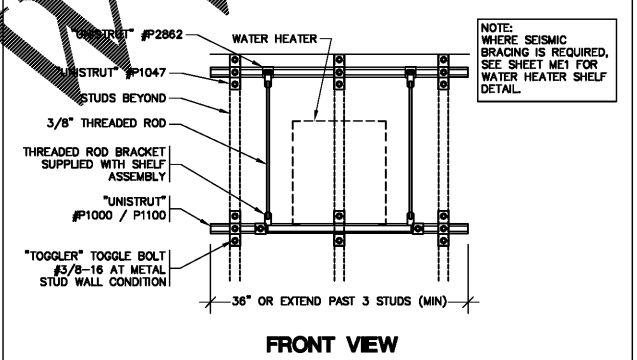
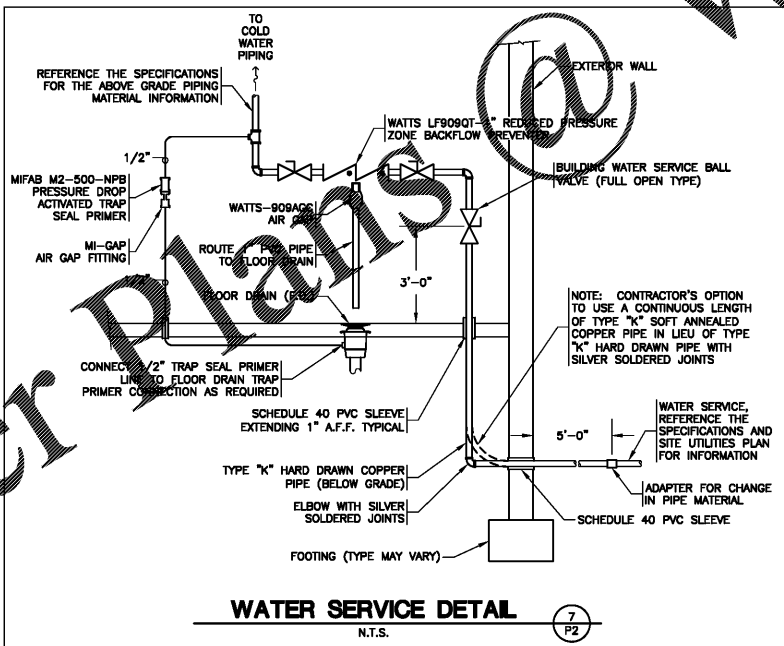
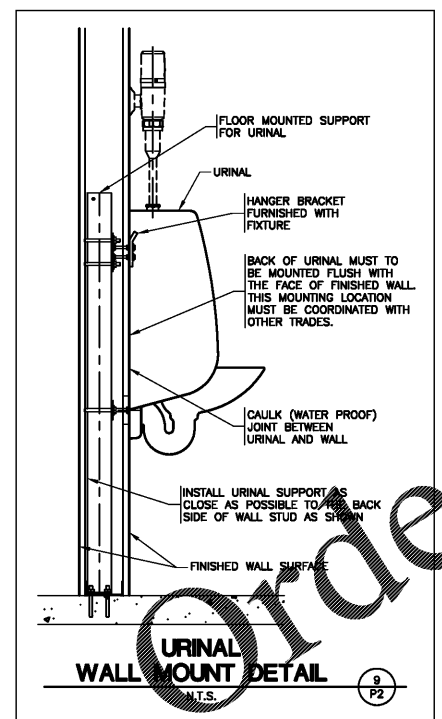
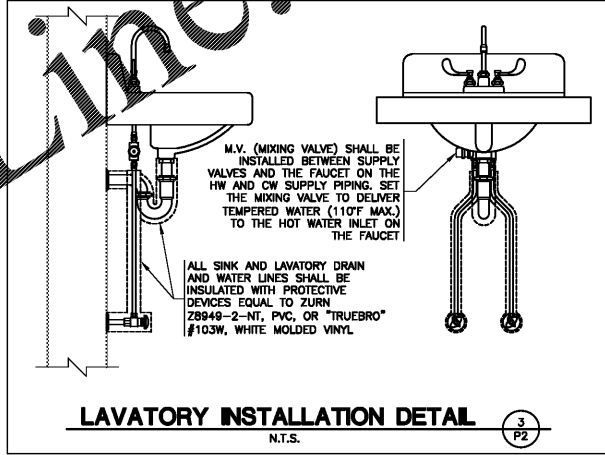
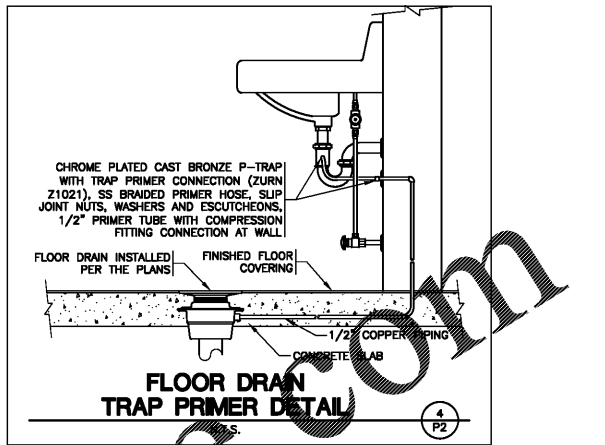
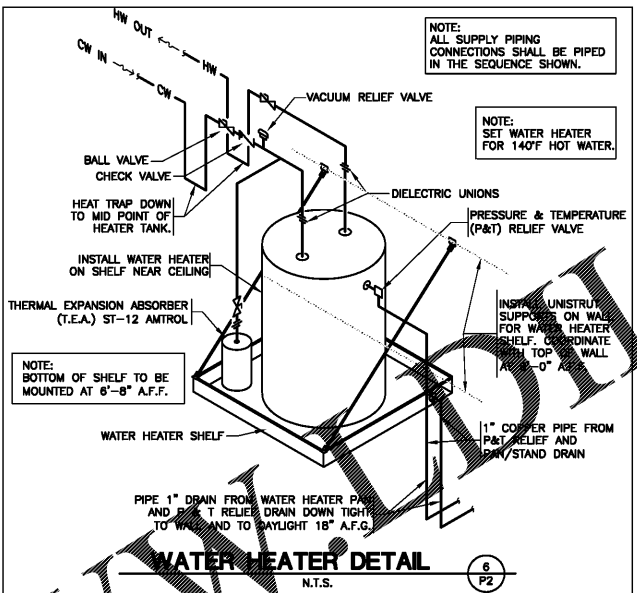
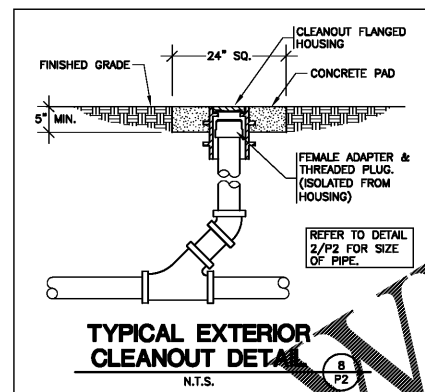

© COPYRIGHT 2019 - DESIGNS, DRAWINGS AND SPECIFICATIONS ARE INSTRUMENTS OF SERVICE AND ARE THE PROPERTY OF THE DESIGN PROFESSIONAL. REPRODUCTION PROHIBITED WITHOUT THE EXPRESSED WRITTEN CONSENT OF THE DESIGN PROFESSIONAL.