

- CONSTRUCTION SPECIFICATIONS**
- STONE - USE COARSE AGGREGATE (2 - 3 INCH STONE)
 - LENGTH - AS EFFECTIVE, BUT NOT LESS THAN 100 FEET.
 - THICKNESS - NOT LESS THAN EIGHT (8) INCHES.
 - WIDTH - NOT LESS THAN FULL WIDTH OF ALL POINTS OF INGRESS OR EGRESS.
 - WASHING - WHEN NECESSARY, WHEELS SHALL BE CLEANED TO REMOVE SEDIMENT PRIOR TO ENTRANCE ONTO PUBLIC RIGHT-OF-WAY. WHEN WASHING IS REQUIRED, IT SHALL BE DONE ON AN AREA STABILIZED WITH CRUSHED STONE WHICH DRAINS INTO AN APPROVED SEDIMENT TRAP OR SEDIMENT BASIN. ALL SEDIMENT SHALL BE PREVENTED FROM ENTERING ANY STORM DRAIN, DITCH, OR WATERCOURSE THROUGH USE OF SAND BAGS, GRAVEL, BOARDS OR OTHER APPROVED METHODS.
 - MAINTENANCE - THE ENTRANCE SHALL BE MAINTAINED IN A CONDITION WHICH WILL PREVENT TRACKING OR FLOWING OF SEDIMENT ONTO PUBLIC RIGHT-OF-WAY. THIS MAY REQUIRE PERIODIC TOP DRESSING WITH ADDITIONAL STONE AS CONDITIONS DEMAND AND REPAIR AND/OR CLEANOUT OF ANY MEASURES USED TO TRAP SEDIMENT. ALL SEDIMENT SPILLED, DROPPED, WASHED OR TRACKED ONTO PUBLIC RIGHTS-OF-WAY MUST BE REMOVED IMMEDIATELY.
 - 12' X 24' METAL GRATE MAY BE USED. GRATE SHALL BE 25' AWAY FROM PAVEMENT AND APPROPRIATE SEDIMENT CONTROL TRAPPING DEVICE SHALL BE USED AT GRATE OUTLET POINT.

CONSTRUCTION EXIT DETAIL
N.T.S.

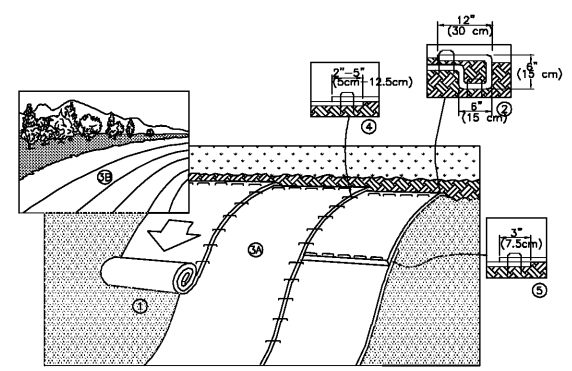

EROSION CONTROL BLANKET DETAIL
FOR SLOPE INSTALLATION

- PREPARE SOIL BEFORE INSTALLING BLANKETS, INCLUDING ANY NECESSARY APPLICATION OF LIME, FERTILIZER, AND SEED. NOTE: WHEN USING CELL-O-SEED DO NOT SEED PREPARED AREA. CELL-O-SEED MUST BE INSTALLED WITH PAPER SIDE DOWN.
- BEGIN AT THE TOP OF THE SLOPE BY ANCHORING THE BLANKET IN A 4" (10cm) WIDE TRENCH WITH APPROXIMATELY 12" (30cm) OF BLANKET EXTENDED BEYOND THE UP-SLOPE PORTION OF THE TRENCH. ANCHOR THE BLANKET WITH A ROW OF STAPLES/STAKES APPROXIMATELY 12" (30cm) APART IN THE BOTTOM OF THE TRENCH. BACKFILL AND COMPACT THE TRENCH AFTER STAPLING. APPLY SEED TO COMPACTED SOIL AND FOLD REMAINING 12" (30cm) PORTION OF THE BLANKET BACK OVER SEED AND COMPACTED SOIL. SECURE BLANKET OVER COMPACTED SOIL WITH A ROW OF STAPLES/STAKES SPACED APPROXIMATELY 12" (30cm) APART ACROSS THE WIDTH OF THE BLANKET.
- ROLL THE BLANKETS (A) DOWN OR (B) HORIZONTALLY ACROSS THE SLOPE. BLANKETS WILL UNROLL WITH THE APPROPRIATE SIDE AGAINST THE SOIL SURFACE. ALL BLANKETS MUST BE SECURELY FASTENED TO SOIL SURFACE BY PLACING STAPLES/STAKES IN APPROPRIATE LOCATIONS AS SHOWN IN THE STAPLE PATTERN GUIDE. WHEN USING OPTIONAL DOT SYSTEM, STAPLES/STAKES SHOULD BE PLACED THROUGH EACH OF THE COLORED DOTS CORRESPONDING TO THE APPROPRIATE STAPLE PATTERN.
- THE EDGES OF PARALLEL BLANKETS MUST BE STAPLED WITH APPROXIMATELY 2"-5" (5cm-12.5cm) OVERLAP DEPENDING ON BLANKET TYPE. TO ENSURE PROPER SEAM ALIGNMENT, PLACE THE EDGE OF THE OVERLAPPING BLANKET (BLANKET BEING INSTALLED ON TOP) EVEN WITH THE COLORED SEAM STITCH ON TOP PREVIOUSLY INSTALLED BLANKET.
- CONSECUTIVE BLANKETS SPICED DOWN THE SLOPE MUST BE PLACED END OVER END (SHINGLE STYLE) WITH AN APPROXIMATE 3" (7.5cm) OVERLAP. STAPLE THROUGH OVERLAPPED AREA, APPROXIMATELY 12" (30cm) APART ACROSS ENTIRE BLANKET WIDTH.

NOTE: IN LOOSE SOIL CONDITIONS, THE USE OF STAPLE OR STAKE LENGTHS GREATER THAN 6" (15cm) MAY BE NECESSARY TO PROPERLY ANCHOR THE BLANKETS.

MAINTENANCE: AS NEEDED, IF ANY AREAS SHOW EROSION, PULL BACK TAHT PORTION OF THE BLANKET, ADD TAMPED SOIL AND RESEED, THEN RESECURE THE BLANKETS. IF BLANKETS BECOME DISLODGED OR DAMAGED, REPAIR OR REPLACE IMMEDIATELY.

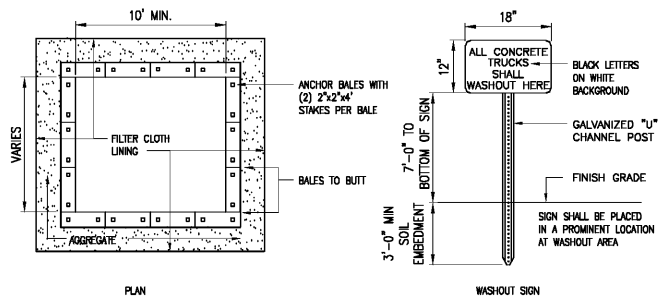

- CONCRETE WASHOUT AREA DETAIL**
N.T.S.
- NOTES:
- WASHOUT AREA(S) SHALL BE INSTALLED IN A LOCATION EASILY ACCESSIBLE BY CONCRETE TRUCKS.
 - ONE OR MORE AREAS MAY BE INSTALLED ON THE CONSTRUCTION SITE AND MAY BE RELOCATED AS CONSTRUCTION PROGRESSES.
 - AT LEAST WEEKLY REMOVE ACCUMULATION OF SAND AND AGGREGATE AND DISPOSE OF PROPERLY.

CONCRETE WASHOUT AREA DETAIL
N.T.S.

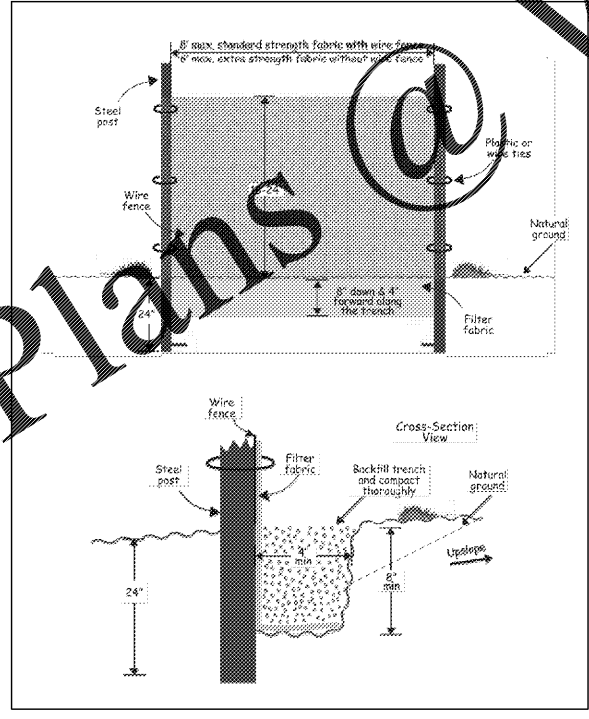

MAINTENANCE: INSPECT SEDIMENT FENCES AT LEAST ONCE A WEEK AND AFTER EACH RAINFALL. MAKE ANY REQUIRED REPAIRS IMMEDIATELY. SHOULD THE FABRIC OF A SEDIMENT FENCE COLLAPSE, TEAR, DECOMPOSE OR BECOME INEFFECTIVE, REPLACE IT PROMPTLY. REMOVE SEDIMENT DEPOSITS WHEN SOX CAPACITY IS REACHED OR AS NECESSARY TO PROVIDE ADEQUATE STORAGE VOLUME FOR THE NEXT RAIN AND TO REDUCE PRESSURE ON THE FENCE. TAKE CARE TO AVOID UNDERMINING THE FENCE DURING CLEANOUT. REMOVE ALL FENCING MATERIALS AND UNSTABLE SEDIMENT DEPOSITS AND BRING THE AREA TO GRADE AND STABILIZE IT AFTER THE CONTRIBUTING DRAINAGE AREA HAS BEEN PROPERLY STABILIZED.

SILT FENCE DETAIL
N.T.S.

DIAMETER	O.D.	RECOMMENDED TRENCH WIDTH
4"	4.72"	21"
6"	6.96"	23"
8"	9.16"	25"
10"	11.31"	28"
12"	14.49"	31"
15"	17.65"	34"
18"	21.10"	39"
24"	28.30"	48"
30"	36.10"	68"
36"	42.25"	78"
42"	47.00"	83"
48"	53.00"	89"

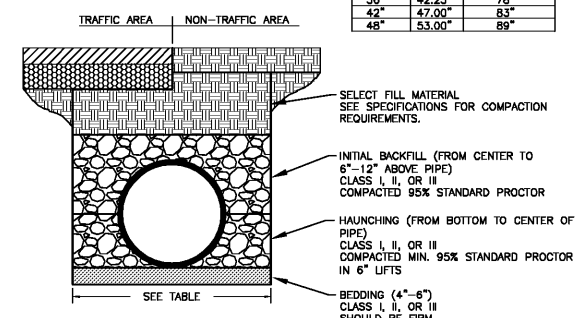

HDPE PIPE TRENCHING & BACKFILL REQUIREMENTS

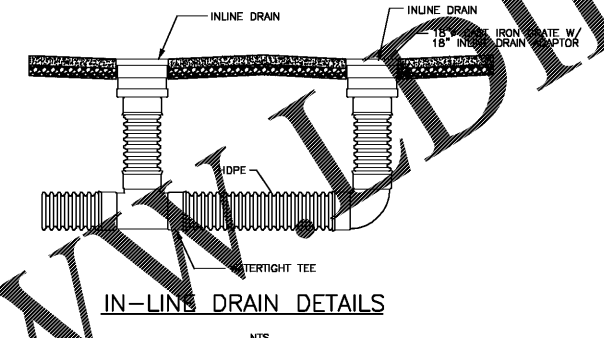

IN-LINE DRAIN DETAILS
N.T.S.

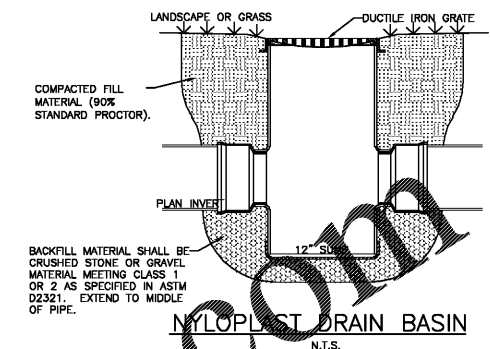

NYLOPEST DRAIN BASIN
N.T.S.

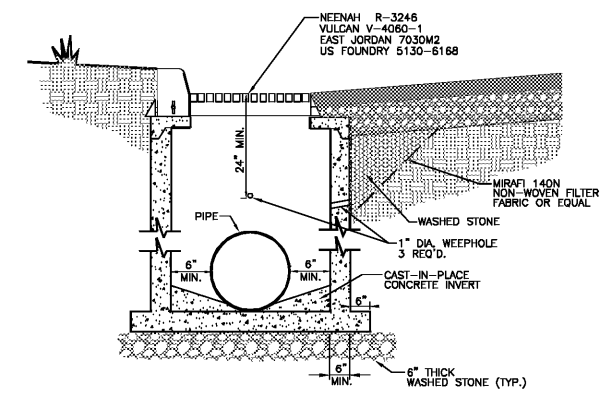

CURB INLET WITH GRATE
N.T.S.

PRE-CAST CATCH BASIN, TRAFFIC RATING.

SITE GRADING/STORM CONTRACTOR SHALL BE RESPONSIBLE FOR MAINTENANCE OF ALL CATCH BASINS DURING CONSTRUCTION.

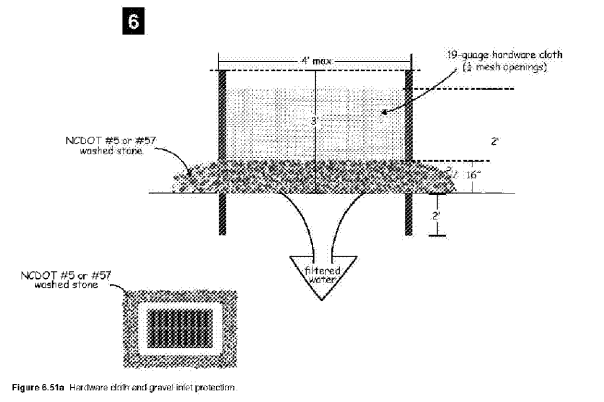

- Construction Specifications**
- Thoroughly grade a shallow depression approaching the inlet.
 - Drive 5-foot steel posts 2 feet into the ground surrounding the inlet. Space posts evenly around the perimeter of the inlet, a maximum of 4 feet apart.
 - Surround the posts with wire mesh hardware cloth. Secure the wire mesh to the steel posts at the top, middle, and bottom. Placing a 2-foot flap of the wire mesh under the gravel for anchoring is recommended.
 - Place clean gravel (NO. 10 or #57 stone) on a 2:1 slope with a height of 16 inches around the wire mesh and smooth to its new grade.
 - Once the contributing drainage area has been stabilized, remove accumulated sediment, and establish final grading elevations.
 - Compact the area properly and stabilized it with groundcover.
- Maintenance**
- Inspect inlets at least weekly and after each significant (1/2 inch or greater) rainfall event. Clear the mesh size of any debris or other objects to provide adequate flow for subsequent rains. Take care not to damage or undercut the wire mesh during sediment removal. Replace stone as needed.
- References**
- 6.52, Block and Gravel Inlet Protection
6.54, Rock Doughnut Inlet Protection
North Carolina Department of Transportation
Standard Specifications for Roads and Structures

HARDWARE CLOTH & GRAVEL INLET PROTECTION DETAIL

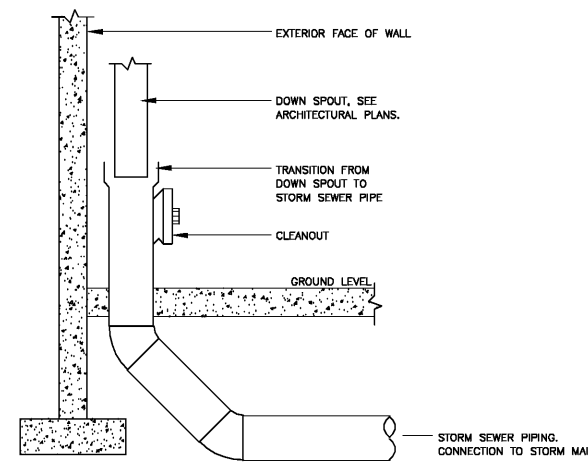

BUILDING DOWNSPOUT CONNECTION DETAIL
N.T.S.

BERRY ENGINEERS LLC
CIVIL ENGINEER
3665 BELLEFAY BLVD, SUITE 109
CLEVELAND, TN 37312
TEL: (615) 790-5880
DBA BERRY ENGINEERS, PLLC; FIRM LICENSE: P-1188

DEVELOPER:
BELTERRA PARTNERS, LLC.
728 SHADES CREEK PKWY
SUITE 130
BIRMINGHAM, AL 35209

PROJECT:
O'REILLY AUTO PARTS
2801 S MIAMI BLVD
DURHAM, NC

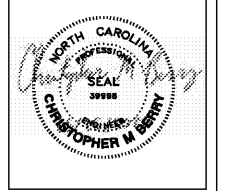

REVISIONS	
1	
2	
3	
4	
5	
6	
7	
8	
9	
10	

SHEET NAME:
SITE DETAILS

DATE: 06/15/2019
DRAWN BY: CSH
CHECKED BY: CMB
PROJECT NO.: 19065
SHEET NUMBER:
C-08