

SYMBOL LEGEND					
DEVICE	SYMBOL	QTY.	DEVICE	SYMBOL	QTY.
DOOR CONTACT	(C)	5	Dome	(D)	16
HORN/SOUNDER	(SN)	1	14" Monitor	(M)	1
CONTROL PANEL	(CP)	1	DIGITAL VIDEO RECORDER	(DVR)	1
KEY PAD	(KP)	2	IEI KEYPAD	(IEI)	1
MOTION DETECTOR (CEILING MOUNT)	(M)	2	EXTERIOR DOME CAMERA (Additional camera for dual drive-thru design)	(D)	5
GLASS BREAK	(GB)	5	STROBE LIGHT	(SL)	1
HOLD UP BUTTON (Additional button for 2nd drive-thru window design)	(HUB)	6	PIEZO	(P)	1

VERIFY LOW VOLTAGE PERMIT REQUIREMENTS

ELECTRICAL REQUIREMENTS

ELECTRICAL SUPPLY ALL 120 VAC FOR CAMERA SYSTEM AND BURGLAR ALARM SYSTEM.
 SUPPLY 120 VAC FOR BURGLAR ALARM PANEL.
 FOR OUTDOOR CAMERAS ALL TRENCHING, CONDUIT AND PULL STRINGS, AS WELL AS A BACK BOX MOUNTED ON THE POLE FOR ELECTRICAL AND COAX CONNECTIONS.
 SECURITY CO. SUPPLY AND INSTALL ALL SECURITY EQUIPMENT RUN ALL LOW VOLTAGE CABLE FOR THE SECURITY SYSTEM. SET UP, TEST AND TRAIN ON CCTV AND BURGLAR ALARM SYSTEMS. SPECIFY ALL LOCATIONS OF DEVICES.

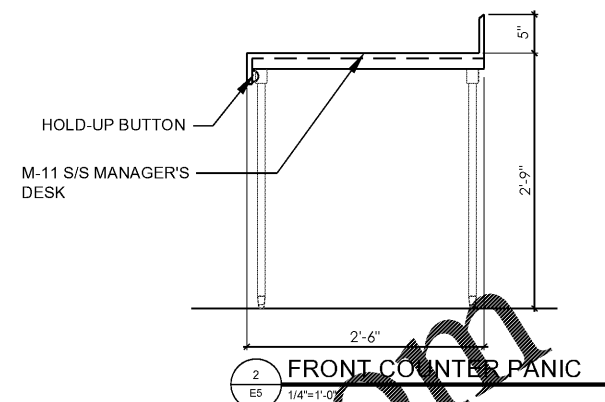

POPEYES INSTALLATION NOTES

NOTE: PROGRAMMING SEQUENCE SET UP AT THE NCCD FOR LOCATIONS WITH OUTDOOR CAMERAS. OUTDOOR POLE MOUNT 15' ABOVE FINISHED PAVEMENT. USE GROUND ISOLATION TRANSFORMERS.

SECURITY CO. TO RUN FLEX CONDUIT INSIDE LIGHT POLES. EC TO RUN CONDUIT FROM RESTAURANT TO BASE OF LIGHT POLE & MOUNT JUNCTION BOX 15' ABOVE FINISHED PAVEMENT ON POLE.

OUTDOOR CAMERAS

- A-1 DRIVE THRU WINDOW AND CAR STACK
- A-2 SECONDARY SINGLE ENTRY DOOR
- A-3 MAIN DOUBLE ENTRY DOOR
- A-4 REAR ENTRY DOOR
- A-5 ORDER CONFIRMATION BOARD AT DRIVE THRU

INDOOR CAMERAS

INDOOR CEILING MOUNT IN TINTED DOME.
 FASTEN SCREW IN CEILING. DOWNS DO NOT EASILY DROPPED OUT OF TILE.

- B-1 DRIVE THRU WINDOW AND CAR STACK
- B-2 SALES ROOM AREA, H-COUNTER
- B-3 FRONT SALES COUNTER FROM DINING ROOM
- B-4 CONDIMENT AREA, H-COUNTER
- B-5 FRONT SALES COUNTER FROM PRODUCTION COUNTER
- B-6 DRIVE THRU
- B-7 PREPARATION AREA TOWARDS REAR OF BUILDING
- B-8 OFFICE
- B-9 BATTER FRY AREA TOWARDS REAR OF BUILDING
- B-10 REAR DOOR FROM STORAGE AREA
- B-11 STORAGE AREA FROM REAR DOOR
- B-12 WALK IN COOLER (OPTIONAL)
- B-13 WALK IN FREEZER (OPTIONAL)
- B-14 DINING ROOM
- B-15 MAIN DOOR
- B-16 EMPLOYEE LOUNGE

OFFICE AREA

BAC BURGLAR ALARM CONTROL VISTA 205EUL

- D-VCR
- E-VCR
- F-MONITOR

QUICK REFERENCE SHEETS

ALARM INSTRUCTION SHEET TO BE MOUNTED ON WALL IN EMPLOYEE ONLY AREA CLOSEST TO KEYPAD OR IN OFFICE AREA PER CUSTOMER INSTRUCTION

FOR LOCATIONS WITH 6 OR MORE CAMERAS: ADD MULTIPLEXER: LTC 284189-PLACE ON SECURITY LOCK FOR NO TAMPER

FOR LOCATIONS WITH 4 CAMERAS OR LESS: ADD VIDQUAD 4 CHANNEL LTC 227260

HUB: HOLD UP BUTTON 44184 SERIES LATCHING HUB.
 MANAGER AREA 36" AFF OUT OF SITE FROM FRONT COUNTER.

DRIVE-THRU WINDOW 18" AFF & OUT OF SITE FROM OUTSIDE.
 FRYER/PREP AREA

SL STROBE LIGHT - AS SL 4018-BLUE STROBE MOUNT BEHIND MENU BOARD, IT WILL FLASH CONTINUOUSLY WHILE BACK DOOR IS OPEN.

S SOUNDER AS PAL 3284-LOW TONE SOUNDER MOUNT WITH STROBE BEHIND MENU BOARD. IT WILL SOUND WHEN BACK DOOR IS OPENED, MANAGER WILL TONE SILENCE SOUNDER AT KEYPAD AFTER 1 TONE.

MD MOTION DETECTOR AP 669 PIR-360 MOTION MOUNT IN STOVE AREA TO GET AREA FROM DRIVE-UP WINDOW AND GENERAL REAR AREA.

LOBBY/PERIMETER AREA/BACK OF HOUSE

KP: KEYPAD MOUNT 40" AFF
 GB: FG 1025 GLASS BREAK LOBBY GLASS ONE EACH SIDE OF BUILDING SEE DRAWING FOR DEVICE PLACEMENT

C: B4039 CONTACT-ALL EXTERIOR DOORS
 BACK DOOR CONTACT TO ACT AS ALARM POINT FOR BACK DOOR ALARM 24 HOUR LOCATION POINT SOUNDER & BLUE STROBE TO ACTIVATE WHEN BACK DOOR IS OPEN

HUB: 3050CT SERIES LATCHING HUB IN COOLER/FREEZER MOUNT 18" AFF ON HINGE SIDE OF DOOR. STUB UP CONDUIT TO PROTECT WIRING FROM CONDENSATION/DAMAGE NO DRIP LOOP AT HUB

POC: POINT OF CONNECTION TO NKL SAFE-PICTAL PROVIDED BY NKL SAFE

POPEYES ADD ON MODIFICATION NAMES AND PHONE NUMBERS

- INSTALLER PLEASE CONTACT YOUR SECURITY AND ALARM SYSTEM VENDOR FOR ANY ADD-ONS OR MODIFICATIONS TO YOUR JOB. THEY WILL CONTACT THE NATIONAL ACCOUNT MANAGER FOR APPROVALS/PAPERWORK.
- CONTACT THE NATIONAL ACCOUNT MANAGER.

POPEYES PROBLEM RESOLUTION NAMES & PHONE NUMBERS

NCCD PROJECT COORDINATOR:
 NAME:
 PHONE NUMBER:

NATIONAL ACCOUNT MANAGER:
 POPEYES:
 NEW INSTALL/RENOVATION CONSTRUCTION MANAGER:
 EXISTING SITES/RENOVATION PROJECTS/FACILITIES MANAGER:
 LOSS PREVENTION DIRECTOR:

POPEYES INSTALLATION ACCEPTANCE FORM/CHECKLIST

FOR INSTALL SITE MODIFICATIONS (E) DEVICE PLACEMENT CHANGES FROM BLUEPRINT, HAVE CUSTOMER INITIAL MODIFY PER SITE OPTION TO SIGN OFF APPROVAL

CAMERAS

A-CAMERA: FOR LOCATIONS WITH OUTDOOR CAMERAS
 OUTDOOR POLE MOUNT 15' ABOVE FINISHED PAVEMENT

GROUND ISOLATION TRANSFORMERS
 YES _____ N/A _____ MODIFY PER SITE _____

A-1 TO RUN CONDUIT INSIDE LIGHT POLES-EC TO RUN CONDUIT FROM RESTAURANT TO BASE OF LIGHT POLE MOUNT JUNCTION BOX 15' ABOVE FINISHED PAVEMENT ON POLE

A-1: DRIVE THRU WINDOW AND CAR STACK
 YES _____ N/A _____ MODIFY PER SITE _____

A-2: SECONDARY SINGLE ENTRY DOOR
 YES _____ N/A _____ MODIFY PER SITE _____

A-3: MAIN DOUBLE ENTRY DOOR
 YES _____ N/A _____ MODIFY PER SITE _____

A-4: REAR ENTRY DOOR
 YES _____ N/A _____ MODIFY PER SITE _____

A-5: ORDER CONFIRMATION BOARD AT DRIVE THRU
 YES _____ N/A _____ MODIFY PER SITE _____

FASTEN SCREW IN CEILING FOR DOWNS DO NOT EASILY DROPPED OUT OF TILE
 YES _____ N/A _____ MODIFY PER SITE _____

B-1: DINING ROOM AREA, H-COUNTER
 YES _____ N/A _____ MODIFY PER SITE _____

B-2: DINING ROOM AREA, H-COUNTER
 YES _____ N/A _____ MODIFY PER SITE _____

B-3: FRONT SALES COUNTER FROM DINING ROOM
 YES _____ N/A _____ MODIFY PER SITE _____

B-4: CONDIMENT COUNTER, H-COUNTER AREA
 YES _____ N/A _____ MODIFY PER SITE _____

B-5: FRONT SALES COUNTER FROM PRODUCTION COUNTER
 YES _____ N/A _____ MODIFY PER SITE _____

B-6: DRIVE THRU
 YES _____ N/A _____ MODIFY PER SITE _____

B-7: PREPARATION AREA TOWARDS REAR OF BUILDING
 YES _____ N/A _____ MODIFY PER SITE _____

B-8: OFFICE
 YES _____ N/A _____ MODIFY PER SITE _____

B-9: BATTER FRY AREA TOWARDS REAR OF BUILDING
 YES _____ N/A _____ MODIFY PER SITE _____

B-10: REAR DOOR FROM STORAGE AREA
 YES _____ N/A _____ MODIFY PER SITE _____

B-11: STORAGE AREA FROM REAR DOOR
 YES _____ N/A _____ MODIFY PER SITE _____

B-12 & B-13: COOLER/FREEZER BOXES
 YES _____ N/A _____ MODIFY PER SITE _____

OFFICE AREA

D-VCR LOCK BOX TC9222 SERIES
 YES _____ N/A _____ MODIFY PER SITE _____

E-VCR: LTC 3924 SERIES PLACE ON SECURITY LOCK FOR NO TAMPER
 YES _____ N/A _____ MODIFY PER SITE _____

QUICK REFERENCE SHEETS
 ALARM INSTRUCTION SHEET TO BE MOUNTED ON WALL IN EMPLOYEE ONLY AREA CLOSEST TO KEYPAD OR IN OFFICE AREA PER CUSTOMER INSTRUCTION
 YES _____ N/A _____ MODIFY PER SITE _____

VCR INSTRUCTION SHEET (2) 1-REVIEW & 1-RECORD-TO BE MOUNTED ON WALL CLOSEST TO VCR
 YES _____ N/A _____ MODIFY PER SITE _____

FOR LOCATIONS WITH 6 OR MORE CAMERAS: ADD MULTIPLEXER
 LTC 284189-PLACE ON SECURITY LOCK FOR NO TAMPER
 YES _____ N/A _____ MODIFY PER SITE _____

FOR LOCATIONS WITH 4 CAMERAS OR LESS:
 ADD VIDQUAD 4 CHANNEL LTC 227260
 YES _____ N/A _____ MODIFY PER SITE _____

HUB: HOLD UP BUTTON 44184 SERIES LATCHING HUB
 MANAGER AREA 36" AFF OUT OF SITE FROM FRONT COUNTER
 YES _____ N/A _____ MODIFY PER SITE _____

DRIVE-THRU WINDOW 18" AFF & OUT OF SITE FROM OUTSIDE
 YES _____ N/A _____ MODIFY PER SITE _____

LOBBY/PERIMETER AREA/BACK OF HOUSE

KP: KEYPAD MOUNT 40" AFF WALL ENTERING KITCHEN AREA FROM LOBBY
 YES _____ N/A _____ MODIFY PER SITE _____

GB: FG 1025 GLASS BREAK LOBBY GLASS ONE EACH SIDE OF BUILDING SEE DRAWING FOR DEVICE PLACEMENT
 YES _____ N/A _____ MODIFY PER SITE _____

C: B4039 CONTACT-ALL EXTERIOR DOORS
 YES _____ N/A _____ MODIFY PER SITE _____

BACK DOOR CONTACT TO ACT AS ALARM POINT FOR BACK DOOR ALARM 24 HOUR LOCATION POINT SOUNDER & BLUE STROBE TO ACTIVATE WHEN BACK DOOR IS OPEN
 YES _____ N/A _____ MODIFY PER SITE _____

POC: POINT OF CONNECTION TO NKL SAFE-PICTAL PROVIDED BY NKL SAFE
 YES _____ N/A _____ MODIFY PER SITE _____

FRYER/PREP AREA

SL: STROBE LIGHT AS SL 4018-BLUE STROBE MOUNT BEHIND MENU BOARD, IT WILL FLASH CONTINUOUSLY WHILE BACK DOOR IS OPEN
 YES _____ N/A _____ MODIFY PER SITE _____

S: SOUNDER AS PAL 3284-LOW TONE SOUNDER MOUNT WITH STROBE BEHIND MENU BOARD. IT WILL SOUND WHEN BACK DOOR IS OPENED, MANAGER WILL TONE SILENCE SOUNDER AT KEYPAD AFTER 1 TONE
 YES _____ N/A _____ MODIFY PER SITE _____

MD: MOTION DETECTOR AP 669 PIR-360 MOTION MOUNT IN STOVE AREA TO GET AREA FROM DRIVE-UP WINDOW AND GENERAL REAR AREA
 YES _____ N/A _____ MODIFY PER SITE _____

POPEYES MATERIAL LIST

CAMERAS

A-CAMERA: FOR LOCATIONS WITH OUTDOOR CAMERAS
 2 (P) 15 FT 6 IN GROUND ISOLATION TRANSFORMERS
 LTC 3924 SERIES CAMERA W/ 1/8 IN VMP COAXIAL AUTORS LENS
 TO 1/8 IN BIRDS EYE OUTDOOR HOUSING
 TOSHIBA PILE MOUNT ADAPTER
 ENG CONNECTORS FOR FLEXUM CABLE
 FLEX CONDUIT FOR OUTDOOR CAMERAS RUN INSIDE POLE FOR CABLES

INDOOR CEILING MOUNT IN TINTED DOME
 NOTE: FASTEN SCREW IN CEILING FOR DOWNS DO NOT EASILY DROPPED OUT OF TILE LTC 3924 SERIES CAMERA W/ 1/8 IN VMP COAXIAL AUTORS LENS
 TO 1/8 IN BIRDS EYE OUTDOOR HOUSING
 ENG CONNECTORS FOR FLEXUM CABLE

OFFICE AREA

BAC BURGLAR ALARM CONTROL VISTA 205EUL
 VCR LOCK BOX TC9222 SERIES
 E-VCR: LTC 3924 SERIES PLACE ON SECURITY LOCK FOR NO TAMPER
 FASTER FOR LTC 3924 SERIES
 ALTHOUGH 8-PORTION POWER SUPPLY
 QUAD RESERVE SHEETS

ALARM INSTRUCTION SHEET TO BE MOUNTED ON WALL IN EMPLOYEE ONLY AREA CLOSEST TO KEYPAD OR IN OFFICE AREA PER CUSTOMER INSTRUCTION
 VCR INSTRUCTION SHEET (2) 1-REVIEW & 1-RECORD-TO BE MOUNTED ON WALL CLOSEST TO VCR
 FOR LOCATIONS WITH 6 OR MORE CAMERAS: ADD MULTIPLEXER LTC 284189-PLACE ON SECURITY LOCK FOR NO TAMPER
 FOR LOCATIONS WITH 4 CAMERAS OR LESS: ADD VIDQUAD 4 CHANNEL LTC 227260

HUB: HOLD UP BUTTON 44184 SERIES LATCHING HUB
 MANAGER AREA 36" AFF OUT OF SITE FROM FRONT COUNTER

FRYER/PREP AREA

SL: STROBE LIGHT AS SL 4018-BLUE STROBE MOUNT BEHIND MENU BOARD, IT WILL FLASH CONTINUOUSLY WHILE BACK DOOR IS OPEN
 YES _____ N/A _____ MODIFY PER SITE _____

S: SOUNDER AS PAL 3284-LOW TONE SOUNDER MOUNT WITH STROBE BEHIND MENU BOARD, IT WILL SOUND WHEN BACK DOOR IS OPENED, MANAGER WILL TONE SILENCE SOUNDER AT KEYPAD AFTER 1 TONE
 YES _____ N/A _____ MODIFY PER SITE _____

MD: MOTION DETECTOR AP 669 PIR-360 MOTION MOUNT IN STOVE AREA TO GET AREA FROM DRIVE-UP WINDOW AND GENERAL REAR AREA
 YES _____ N/A _____ MODIFY PER SITE _____

LOBBY/PERIMETER AREA/BACK OF HOUSE

KP: KEYPAD MOUNT 40" AFF WALL ENTERING KITCHEN AREA FROM LOBBY
 YES _____ N/A _____ MODIFY PER SITE _____

GB: FG 1025 GLASS BREAK LOBBY GLASS ONE EACH SIDE OF BUILDING SEE DRAWING FOR DEVICE PLACEMENT
 YES _____ N/A _____ MODIFY PER SITE _____

C: B4039 CONTACT-ALL EXTERIOR DOORS
 YES _____ N/A _____ MODIFY PER SITE _____

BACK DOOR CONTACT TO ACT AS ALARM POINT FOR BACK DOOR ALARM 24 HOUR LOCATION POINT SOUNDER & BLUE STROBE TO ACTIVATE WHEN BACK DOOR IS OPEN
 YES _____ N/A _____ MODIFY PER SITE _____

POC: POINT OF CONNECTION TO NKL SAFE-PICTAL PROVIDED BY NKL SAFE
 YES _____ N/A _____ MODIFY PER SITE _____



SHULTZ ENGINEERING GROUP
 212 N. McDowell St, Suite 204
 Charlotte, NC 28204
 (P) 704.334.7363 (F) 704.347.0093
 www.shultzeg.com | SEG - 20-078
 NC FIRM LICENSE NUMBER: C-0898

POPEYES
 5055 BLUE LAGOON DRIVE
 MIAMI, FLORIDA 33128

THESE DRAWINGS ARE THE PROPERTY OF ARCHITRAVE GROUP PC AND SHALL NOT BE USED OR REPRODUCED WITHOUT THE EXPRESS WRITTEN PERMISSION FROM THE OWNER.

Architrave GROUP PC
 Suite 107
 107 Broad Street
 Phone: (732) 212-0007 Fax: (732) 212-0059
 NJ 08149
 JOSE C. SANTIAGO, RA
 PA 144052529 NC 12765
 VA 01867 MD 16887

POPEYES
 1702 RALEIGH ROAD PKY NW
 WILSON, NORTH CAROLINA
 LOUISIANA KITCHEN PLK DESIGN STANDARDS
 83 SEATS / DUAL-LINE PRODUCTION/PLK171-LD

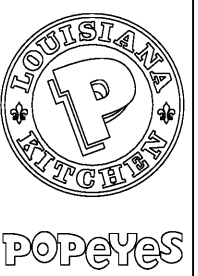

ISSUED FOR REFERENCE ONLY

SECURITY PLAN
E5

REVISIONS

DATE: 3/28/2018
 PROJECT NO: G20-05
 CHECKED: HR

Order Plans

www.pdfline.com

1 SECURITY PLAN
 E5 1/4"=1'-0"