

NOTE:
PROVIDE ELECTRICAL OUTLETS FOR CHARGING STATIONS WITHIN THE CABINETS. SEE ELECTRICAL DWGS.

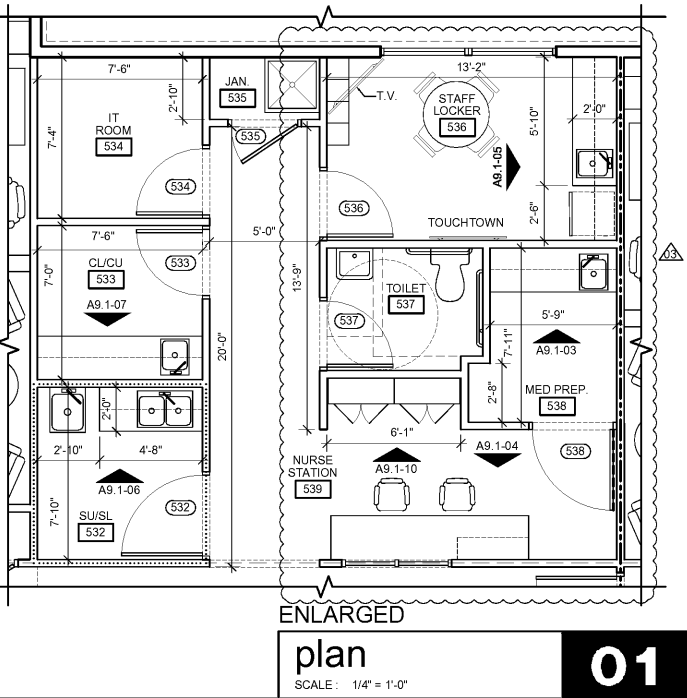
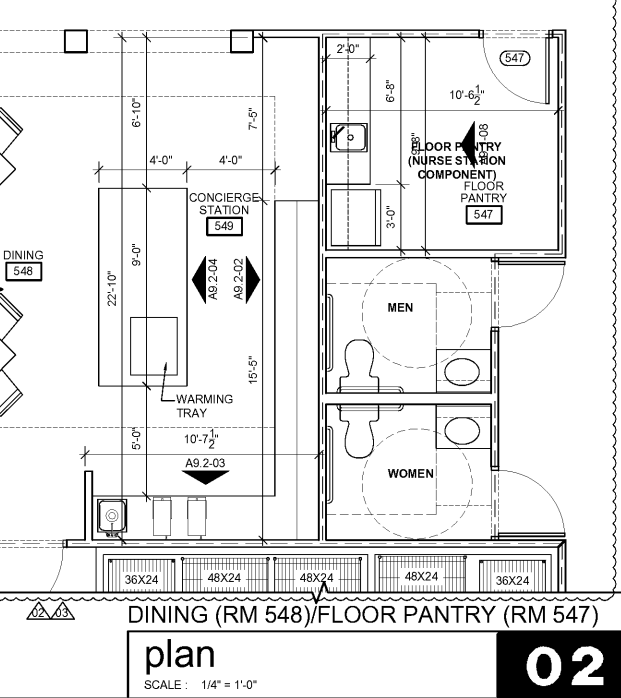
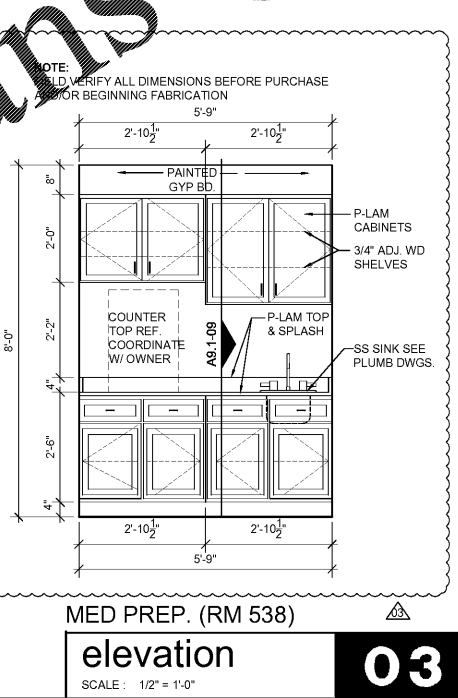
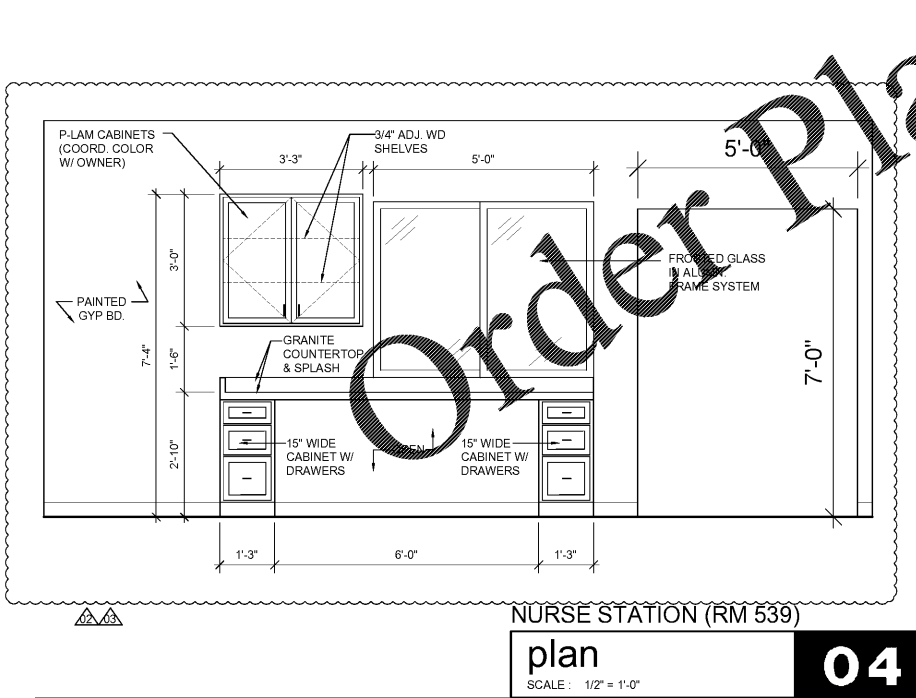
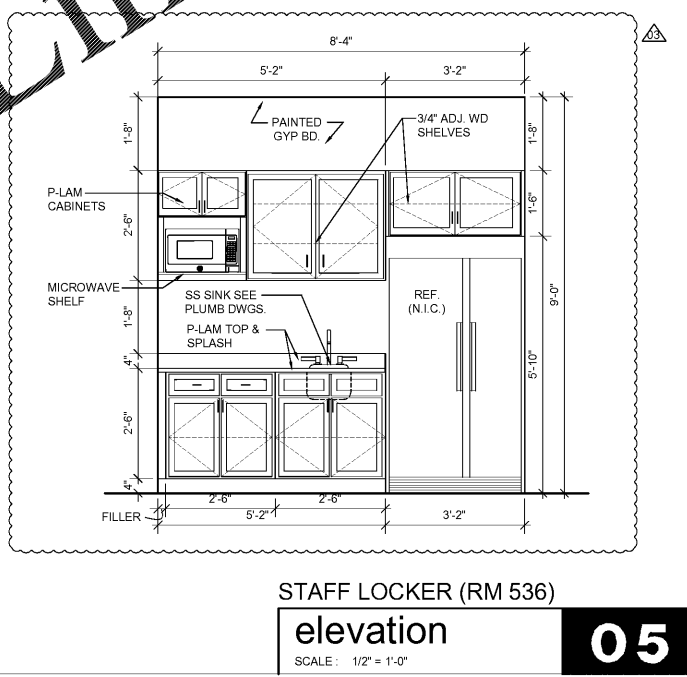
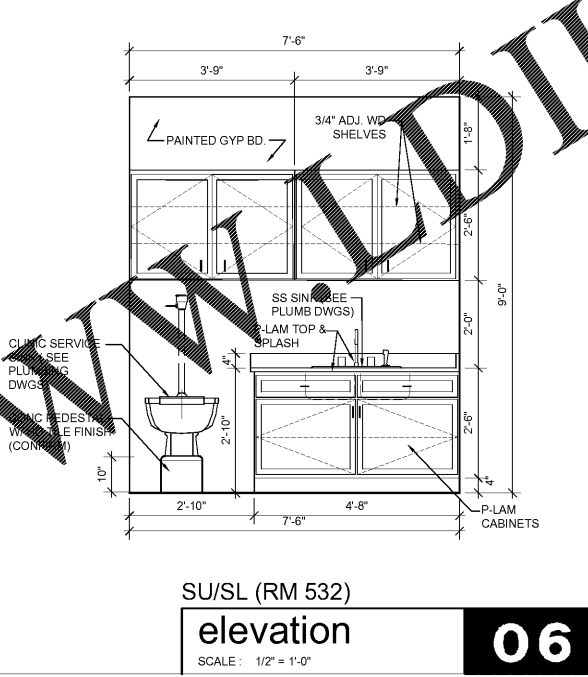
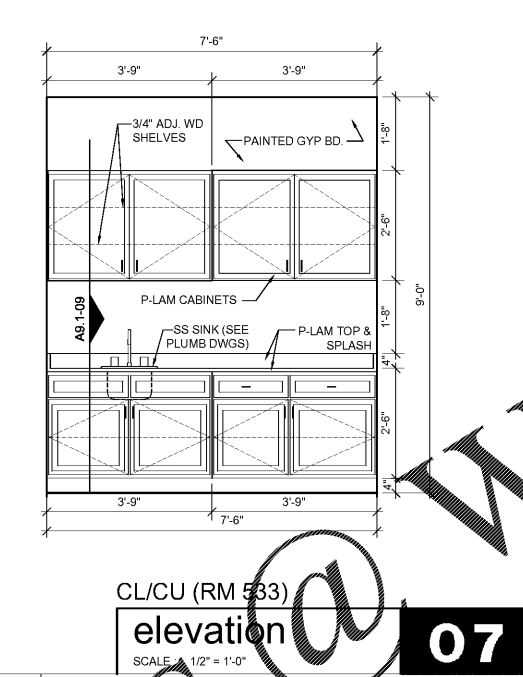
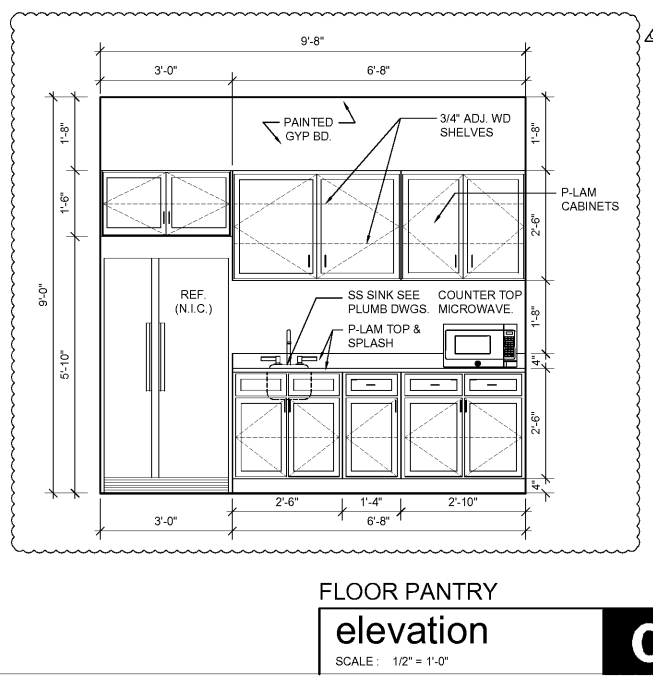
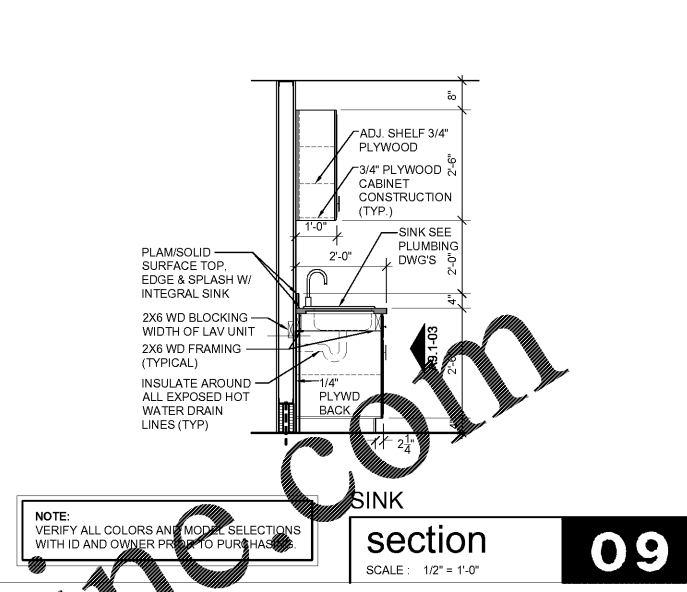
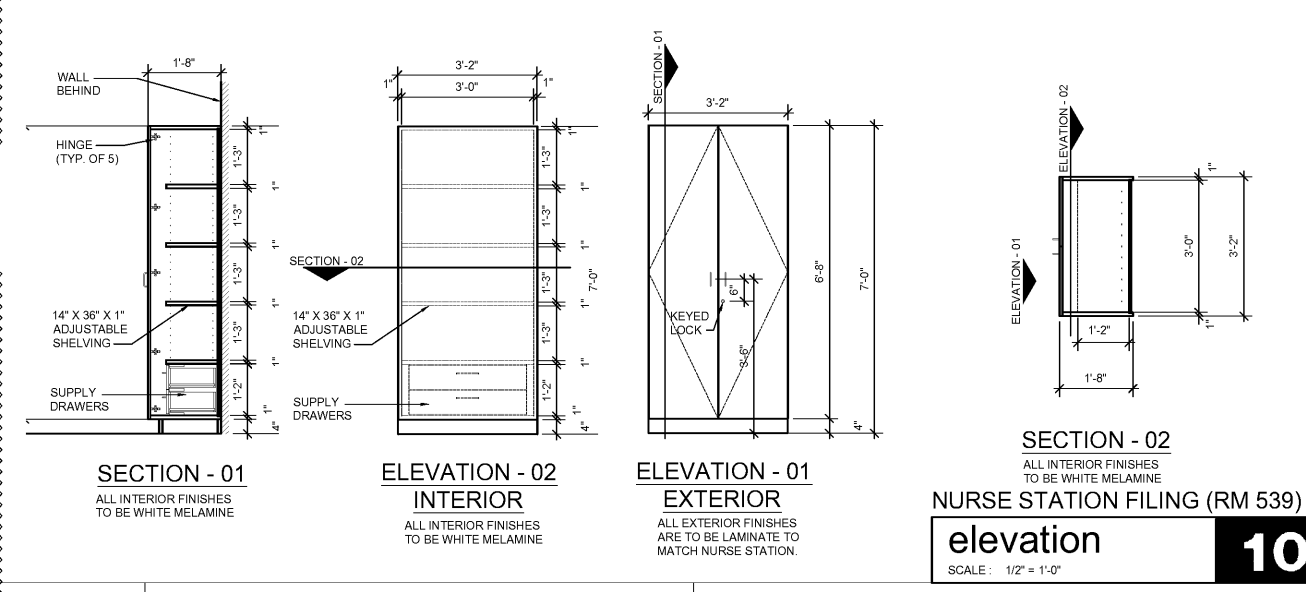

ARCHITECT
TIMOTHY
KURMASKIE
AIA, NCARB

1030 Washington Street
Raleigh, NC 27605
Phone: 919-846-1600
Fax: 919-846-9404
TIM@ARCHITECTSKT.COM

THE DRAWINGS AND DESIGN SHOWN ARE THE PROPERTY OF ARCHITECT TIMOTHY KURMASKIE, AIA, NCARB. THE REPRODUCTION OR USE OF THIS PROPERTY WITHOUT THE WRITTEN CONSENT FROM THE ARCHITECT IS PROHIBITED AND ANY INFRINGEMENT OF THESE RIGHTS IS SUBJECT TO LEGAL ACTION.

Prutt Health

STATE OF GEORGIA
Timothy Kurmaskie
REGISTERED ARCHITECT
06/15/2020

ALTERATION & ADDITION TO:
PruttHealth Savannah
12825 WHITE BLUFF ROAD
SAVANNAH, GA 31419

Project Reference Numbers
Architect's Project No. 180017

Drawn By: NK/WMB

REVISIONS
EQPT REV. 03-26-2020
DCH COM. 04-23-2020
OWNER COM. 06-15-2020

DATES
PHASE ISSUED
PERMIT SET 05/22/19

LARGE SCALE PLANS AND ELEVATIONS

SHEET NUMBER
A9.1