

STEWART - REINDERSMA
ARCHITECTURE, PLLC
5450 E. High Street, Suite 200
Phoenix, Arizona 85054
P: 480.515.5123
www.sra360.com

Christian Brothers
Automotive
Wickham Road
Melbourne, Florida

Christian Brothers
Automotive
1726 Katy Freeway, St. 200
Houston, TX 77054

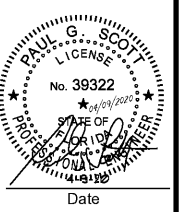

Revisions	
11/13/19 - Prototype Update	
4/1/20 - CITY COMMENTS	

Project No. 19-097

Drawn By: _____
Date: 03/06/20

Sheet Title:
FOUNDATION SECTIONS

Drawing No.

S-7
10RHS-11-2019

PROJECT NUMBER	19-1252	PROJECT MANAGER	RAD
PROJECT ENGINEER	RAD	PROJECT DRAFTER	JSB

THESE DRAWINGS/CALCULATIONS ARE CONSIDERED PRELIMINARY - NOT FOR CONSTRUCTION OR RECORDING UNLESS THE STRUCTURAL ENGINEER OF RECORD'S SEAL IS AFFIXED WITH WRITTEN SIGNATURE.

CARUSO TURLEY SCOTT INC.
consulting structural engineers
1215 W. Rio Salado Pkwy
Suite 200
Tempe, Arizona 85281
(480) 774-1700
(480) 774-1701 FAX
www.ctsar.com

NOTE: LOCATION OF TRENCH DRAIN TO BE COORDINATED WITH PLUMBING

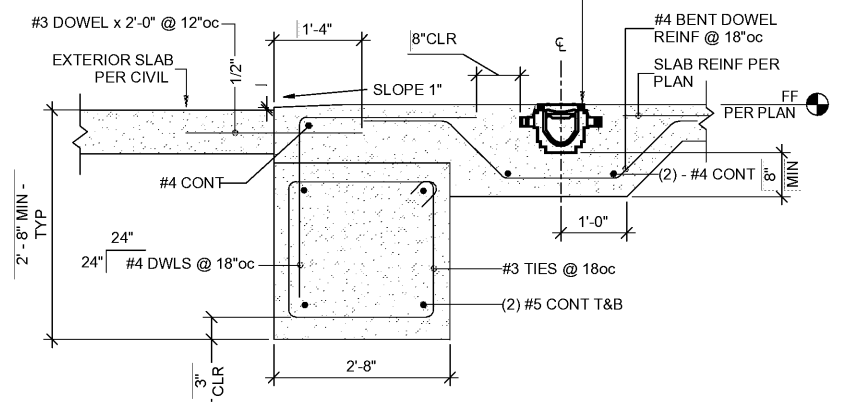

A FOUNDATION SECTION
S-7 N.T.S.

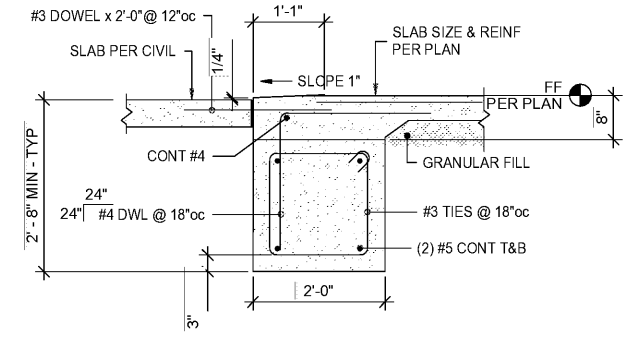

B FOUNDATION SECTION
S-7 N.T.S.

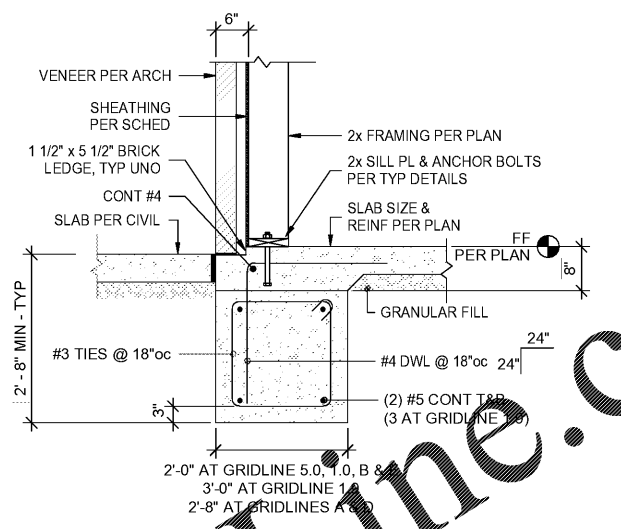

C FOUNDATION SECTION
S-7 N.T.S.

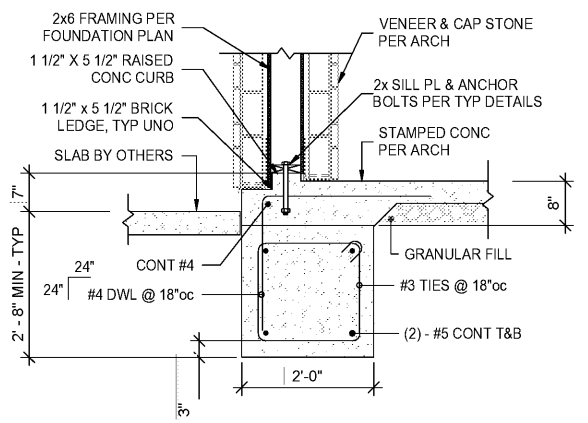

D FOUNDATION SECTION
S-7 N.T.S.

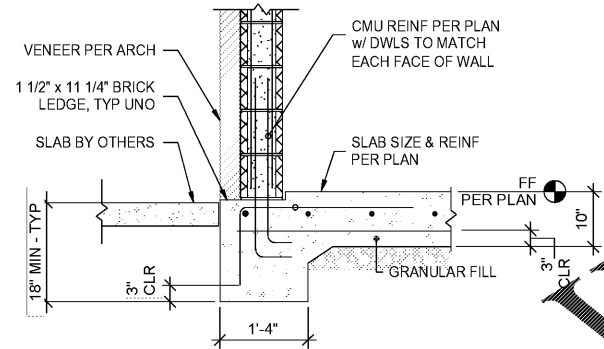

E FOUNDATION SECTION
S-7 N.T.S.

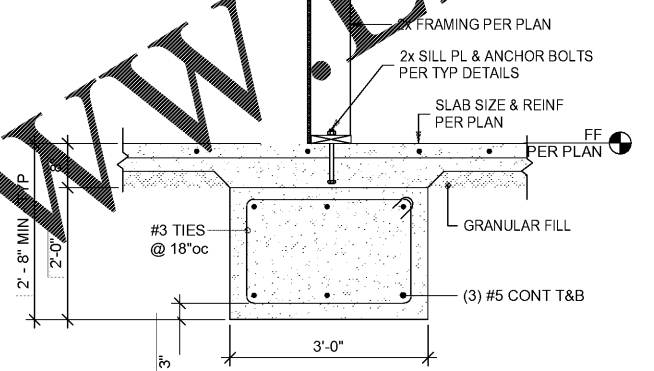

F FOUNDATION SECTION
S-7 N.T.S.

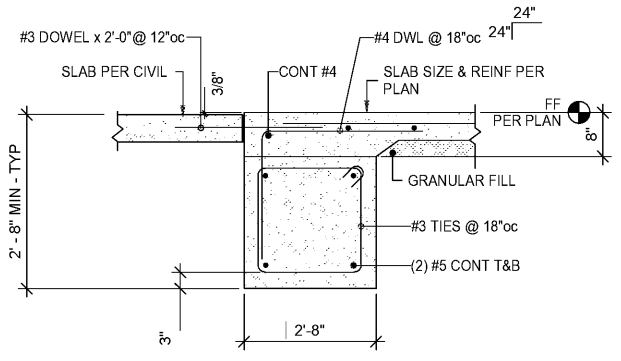

G FOUNDATION SECTION
S-7 N.T.S.

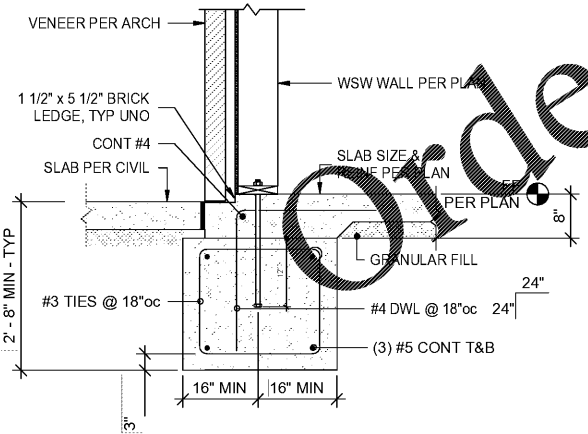

H FOUNDATION SECTION
S-7 N.T.S.

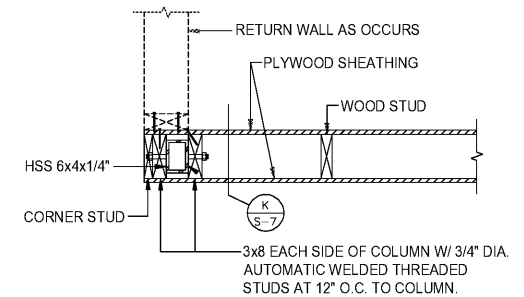

J PLAN VIEW - COLUMN AT SHEARWALL ENDS
S-7 N.T.S.

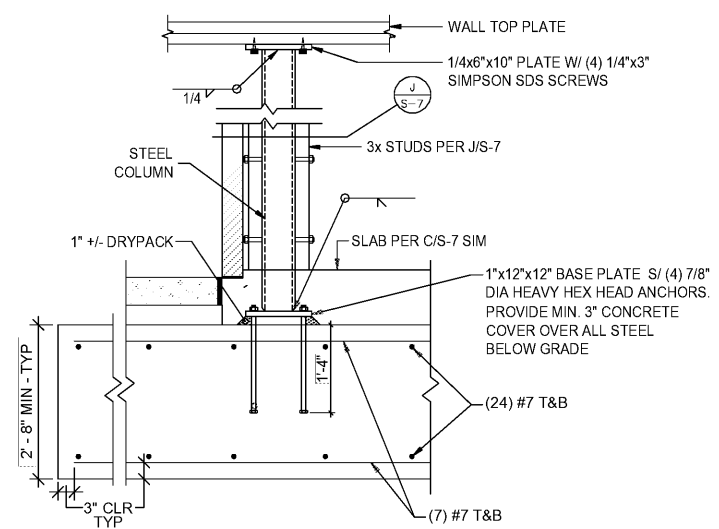

K COLUMN TO FOOTING
S-7 N.T.S.

Order Plans @ WWW.DIYLINE.COM