

1 CMU FOOTING
S301 3/4" = 1'-0"

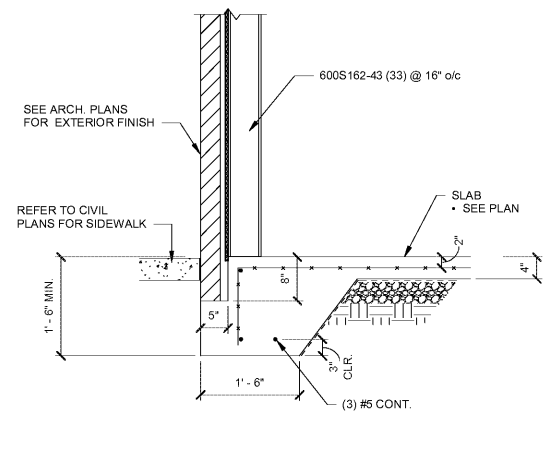

2 TURNDOWN SLAB
S301 3/4" = 1'-0"

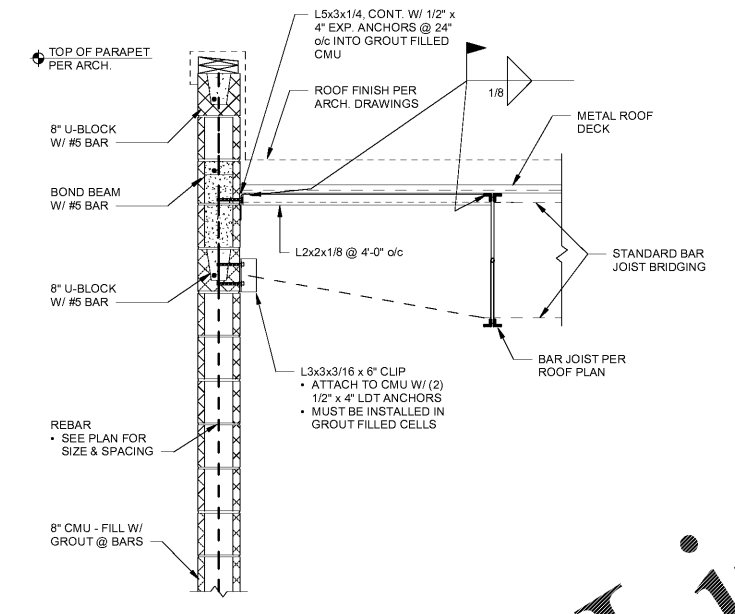

3 BAR JOIST ON CMU - RAKE w/ PARAPET
S301 3/4" = 1'-0"

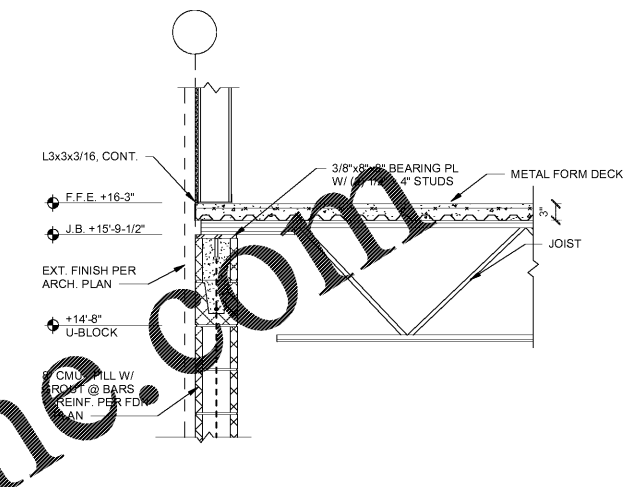

4 MEZZANINE SECTION AT EXTERIOR WALL
S301 3/4" = 1'-0"

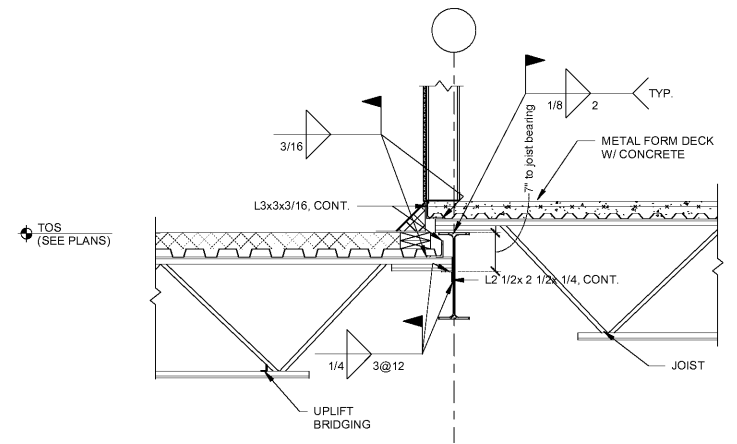

5 MARKET MEZZANINE/ LOW ROOF SECTION
S301 3/4" = 1'-0"

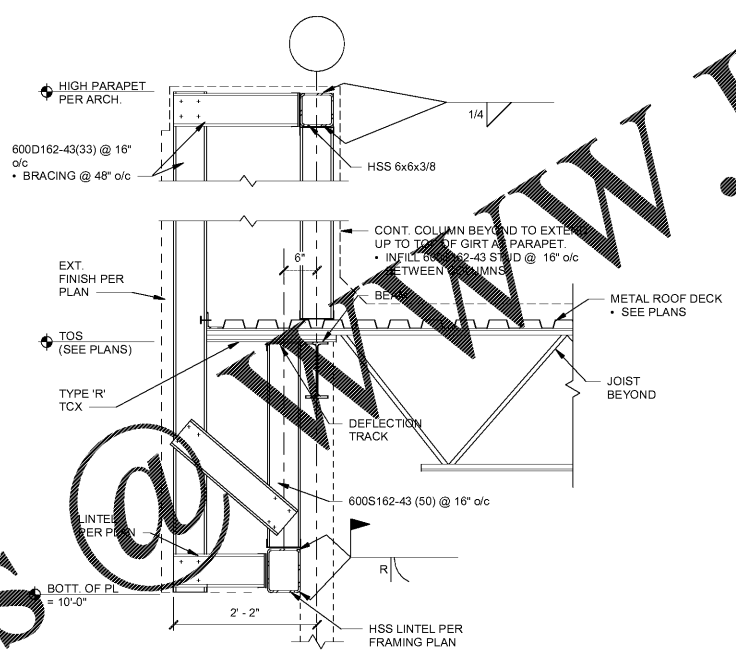

6 ROOF EAVE w/ HSS LINTEL
S301 3/4" = 1'-0"

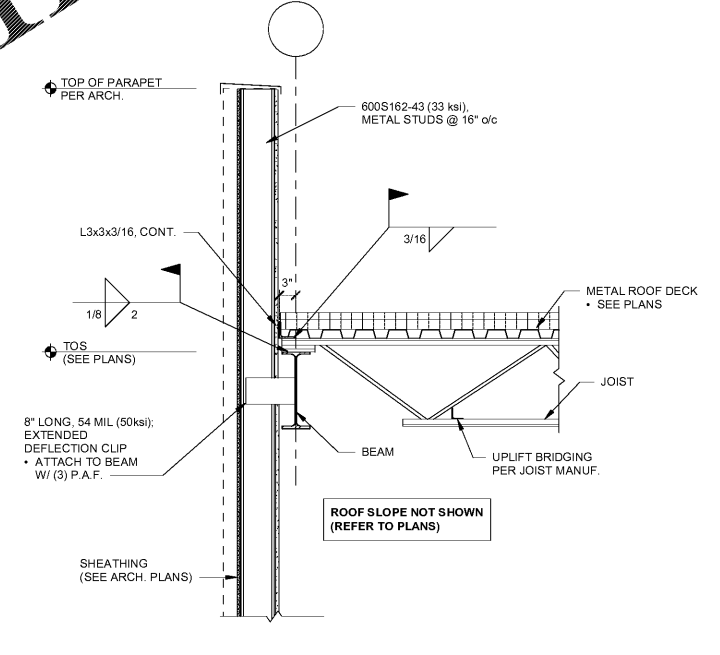

7 DETAIL AT ROOF EAVE
S301 3/4" = 1'-0"

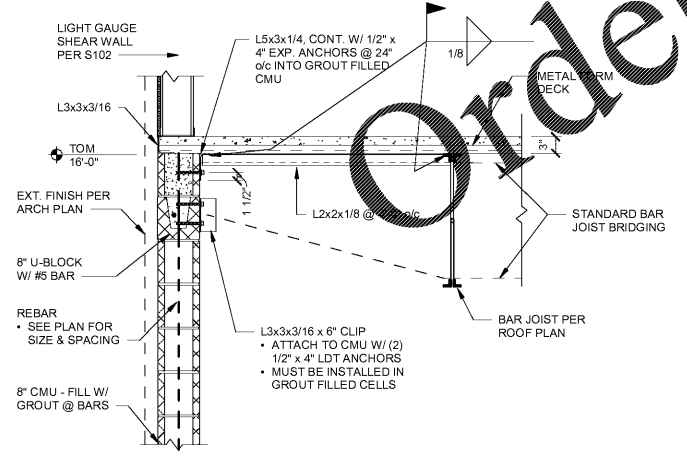

8 FRAMED FLOOR SECTION
S301 3/4" = 1'-0"

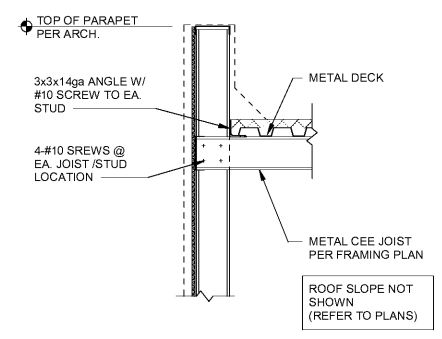

9 MARKET ROOF EAVE
S301 3/4" = 1'-0"

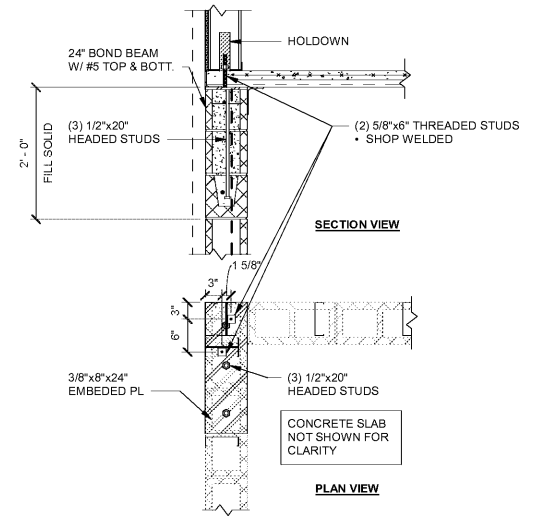

10 MEZZANINE LEVEL HOLDOWN DETAIL
S301 3/4" = 1'-0"

Order Plans @ WWW.LDILine.com

<p>MH STRUCTURES Integrity is our foundation.</p>	<p>engineering consultant</p> <p>5077 Dallas Hwy, Suite 201 Powder Springs, GA 30127 (404) 465-4889 www.mhstructures.com</p> <p>general contractor</p> <p>BLACKWATER CONSTRUCTION 2182 SALLIUM BLVD - SUITE 400 - DALLAS, TEXAS 75297 PH: 469-994-2300 FAX: 469-994-2301 WWW.BLACKWATERCON.COM</p> <p>ISSUED DATE: 5/15/20</p> <p style="text-align: right;">STORE/MARKET BOYD MORRIS ROAD & GA HWY 298 SPUR BARTOW COUNTY, GA</p>
<p>PROJECT NO. 0612001</p> <p>SCALE: 3/4" = 1'-0"</p> <p>DATE: 5/15/20</p>	<p>DRWING NO. S301</p> <p>SHEET OF</p>