

1 KITCHEN ELEVATION
Scale: 3/8" = 1'-0"

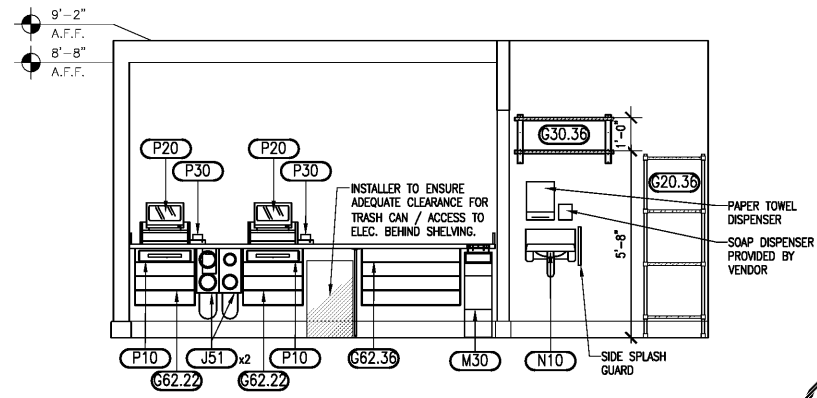

2 KITCHEN ELEVATION
Scale: 3/8" = 1'-0"

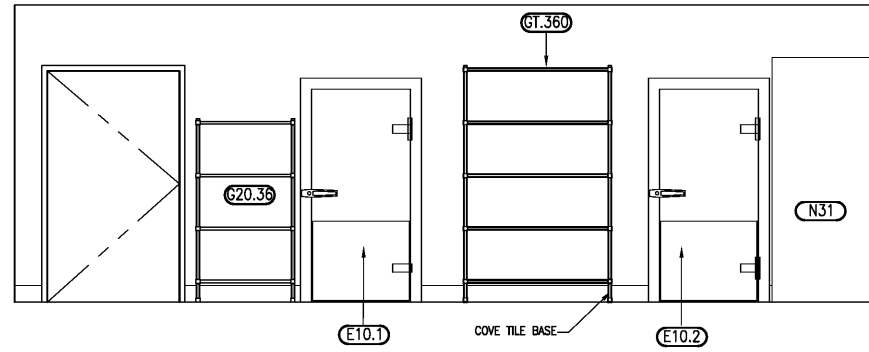

3 KITCHEN ELEVATION
Scale: 3/8" = 1'-0"

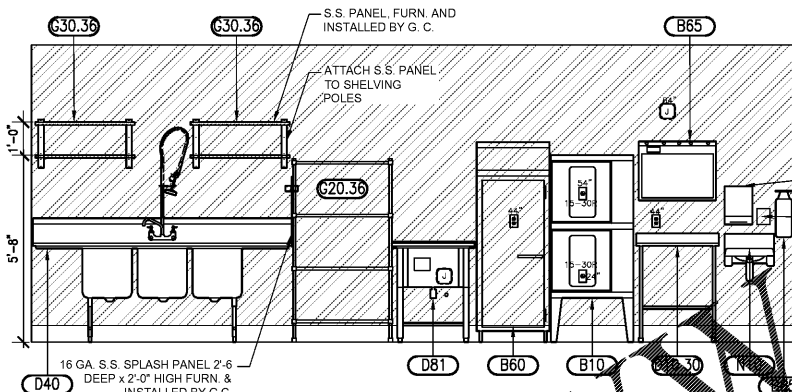

4 KITCHEN ELEVATION
Scale: 3/8" = 1'-0"

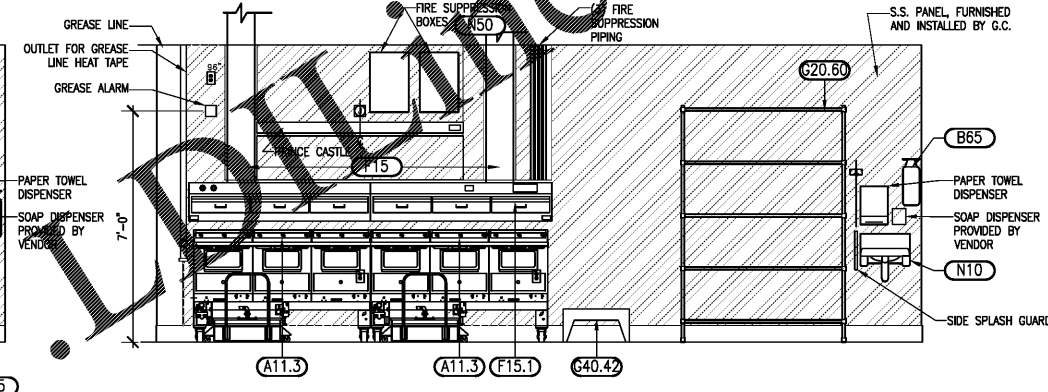

5 KITCHEN ELEVATION
Scale: 3/8" = 1'-0"

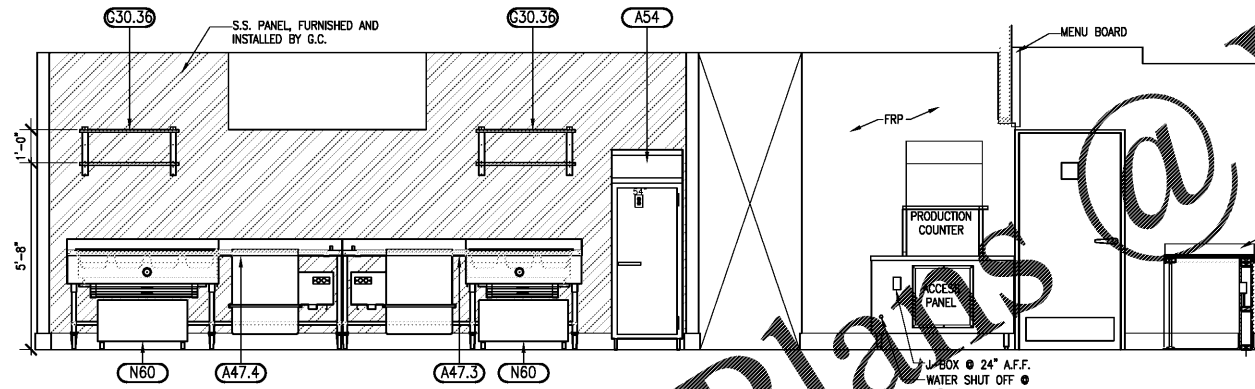

6 KITCHEN ELEVATION
Scale: 3/8" = 1'-0"

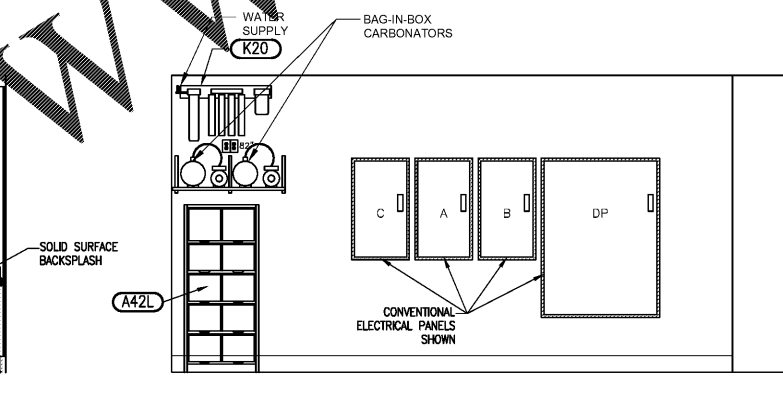

7 KITCHEN ELEVATION
Scale: 3/8" = 1'-0"

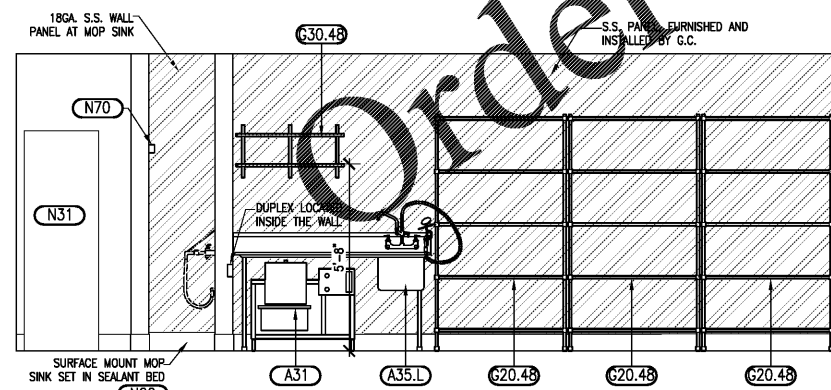

9 INTERIOR ELEVATION
Scale: 3/8" = 1'-0"

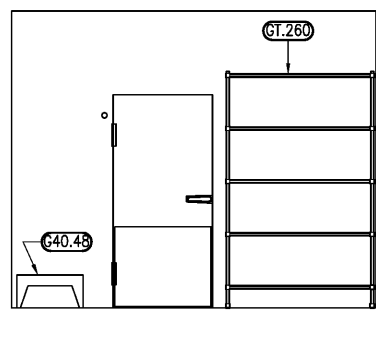

10 INTERIOR ELEVATION - COOLER
Scale: 3/8" = 1'-0"

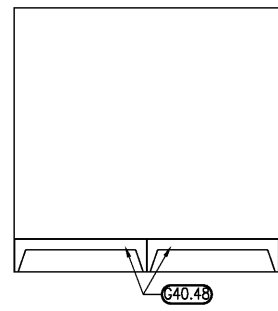

11 INTERIOR ELEVATION - COOLER
Scale: 3/8" = 1'-0"

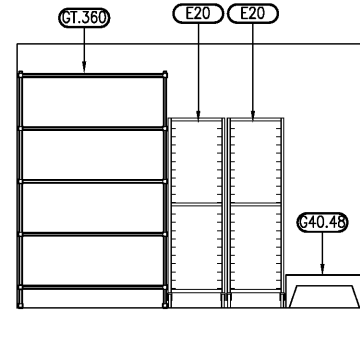

12 INTERIOR ELEVATION - COOLER
Scale: 3/8" = 1'-0"

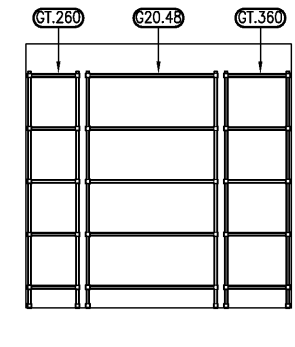

13 INTERIOR ELEVATION - COOLER
Scale: 3/8" = 1'-0"

LEGEND

- DUPLEX RECEPTACLE
- SPECIAL PURPOSE RECEPTACLE
- TELEPHONE OUTLET / DATA OUTLET
- TELEPHONE ONLY OUTLET
- DATA ONLY OUTLET
- JUNCTION BOX
- WATER CONNECTION

NOTES

- DIMENSIONS ARE TAKEN TO THE CENTER LINE OF THE JUNCTION BOXES, (VERT. & HORIZ.)
- PAPER TOWER DISPENSER BY: SAN JAMAR #T1490 TBK FURNISHED AND INSTALLED BY G.C.
- SOAP DISPENSER FURNISHED BY OWNER INSTALLED BY G.C.

LIS ARCHITECTURE ENGINEERING

2150 Palm Beach Blvd
Ave. FL 33400
Phone: (335) 983-8829
Facsimile: (335) 983-8829

LAND INVESTMENT SERVICES, LLC

ARCHITECT ENGINEER

CLIENT NAME
SOUTHEASTERN RETAIL DEVELOPMENT, LLC
BLDG M-1, UNIT Z31
2050 COUNTY ROAD 30A
SANTA ROSA BEACH, FL 32459

PROJECT NAME
POPEYES
PLK 1930-28-DL SAILORMEN
501 N HWY 49
BAYCON, CA 91088

SHEET TITLE
KITCHEN ELEVATIONS

SHEET NO.
A13
KITCHEN ELEVATIONS

HAROLD DANIEL HUTTER III
GEORGIA REG. RA015047

RELEASE	DATE
1	
2	
3	
4	
5	
6	

PROJECT NO.
2020-085

ISSUE DATE
05/07/20

DRAWN
GM

CHECKED
HDH