

1
A11
3'-1'-0"

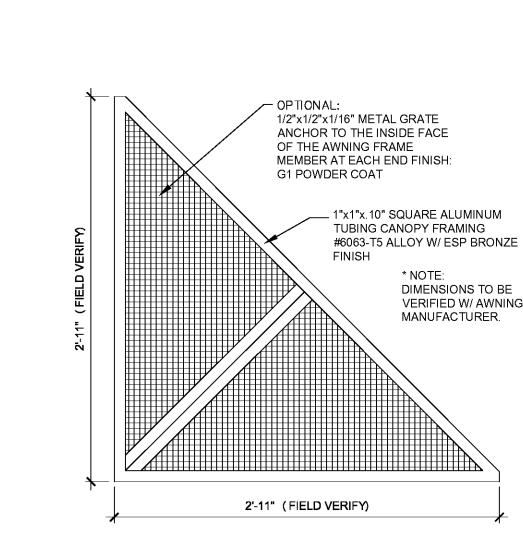

2
A11
1 1/2'-1'-0"

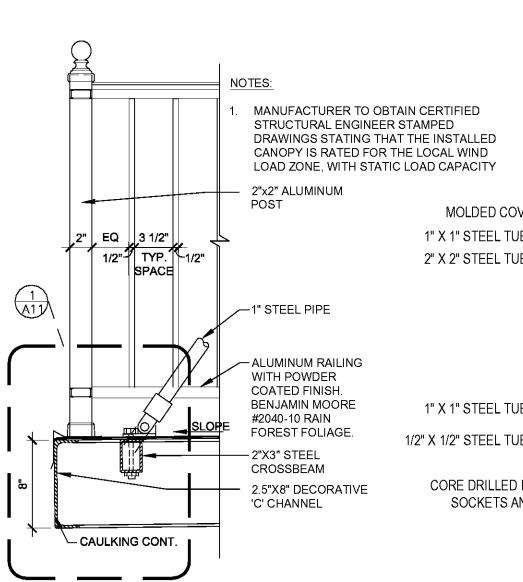

3
A11
1 1/2'-1'-0"

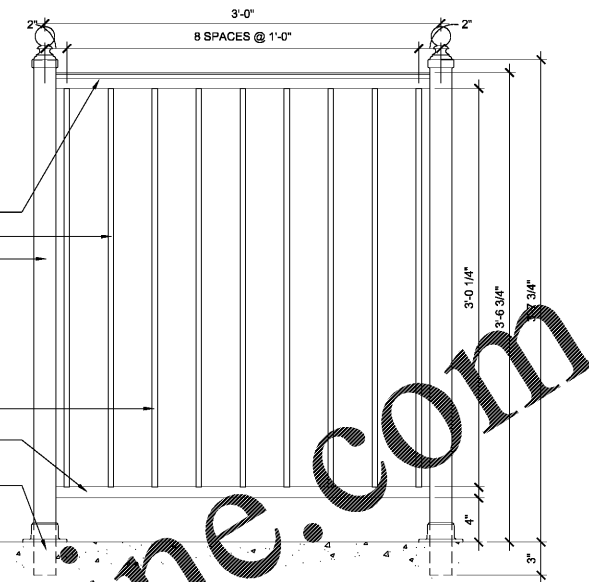

3a
A11
1 1/2'-1'-0"

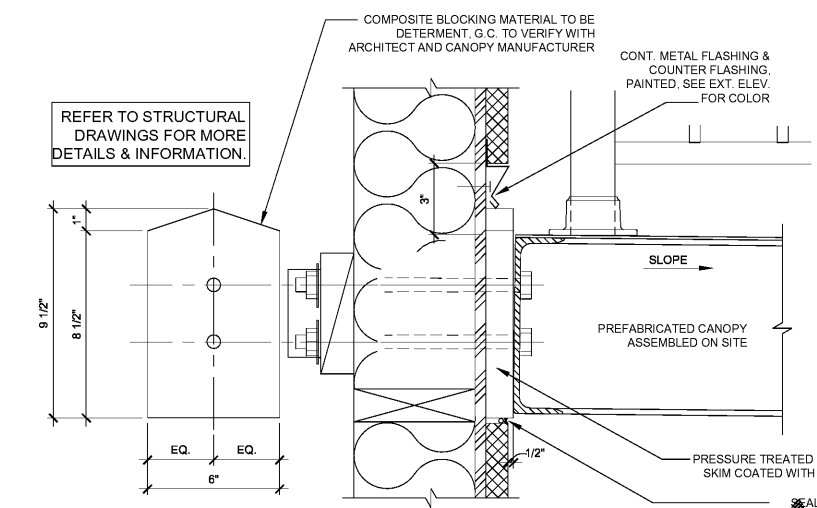

4
A11
3'-1'-0"

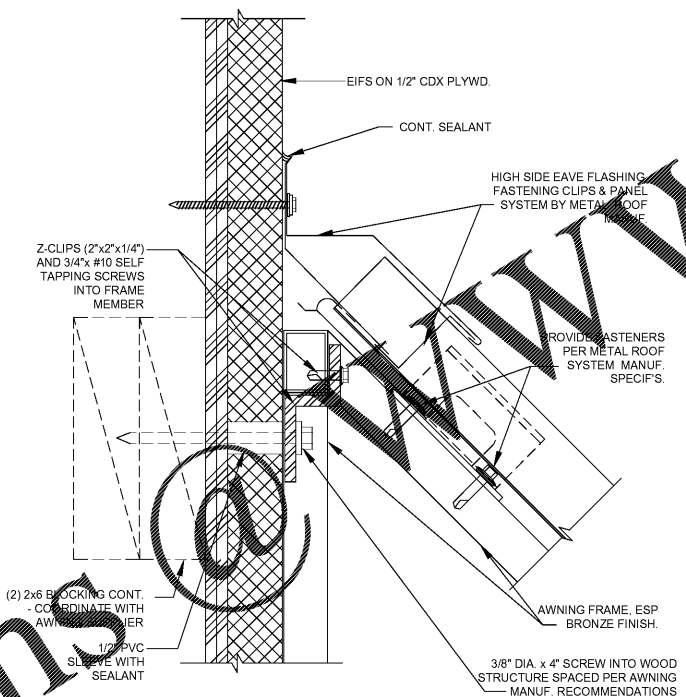

4a
A11
6'-1'-0"

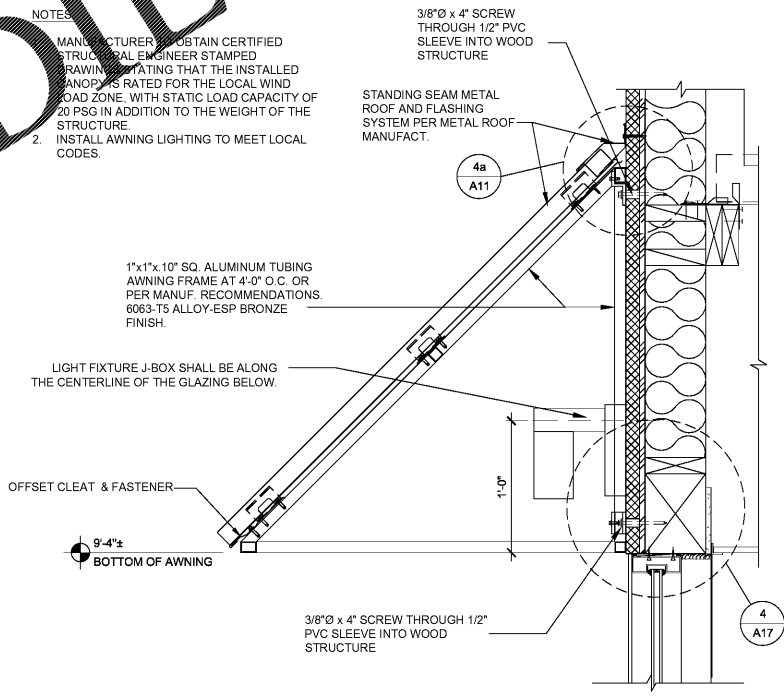

5
A11
1-1/2'-1'-0"

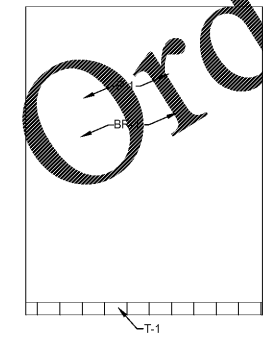

6
A11
3'-6"-1'-0"

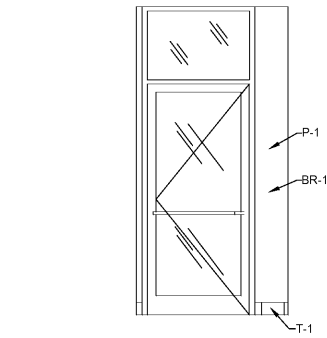

7
A11
3'-6"-1'-0"

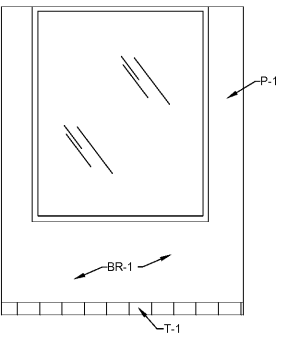

8
A11
3'-6"-1'-0"

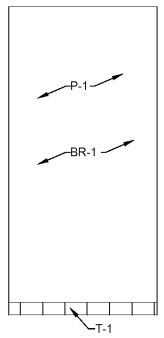

9
A11
3'-6"-1'-0"

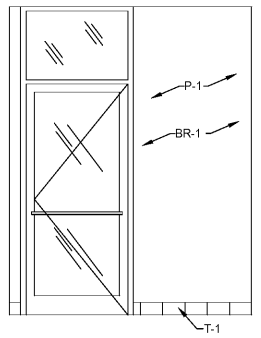

10
A11
3'-6"-1'-0"

FRCH NELSON
A NELSON BRAND
311 Elm Street Suite 600
Cincinnati OH 45202
513 241 3000
www.frchnelson.com

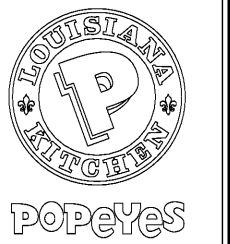

JPL MANAGEMENT

ISSUE INFORMATION

REVISIONS

Nelco Architecture, Inc.

PROJECT INFORMATION

BOWLING GREEN, KY

DISHMAN LANE
BOWLING GREEN, KY 42101

PROJECT #:
20.0001760.000

SHEET INFORMATION

DINING ROOM
ELEVATIONS & DETAILS

AW
DRAWN BY:
JN
REVIEWED BY:

SCALE:

AUTHORIZED FOR:
Permit / Bid

A11

Order Plans @ www.LDILine.com

© 2021 This drawing, printed or otherwise, is the copyrighted property of Nelco Architecture, Inc. The drawing may not be used, reproduced or copied without the permission of Nelco Architecture, Inc.