

**Urban Engineers, Inc.**  
 1904 MONROE DRIVE, N.E., SUITE 150  
 ATLANTA, GEORGIA 30324  
 PHONE: (404) 873-5874  
 www.urbanengineers.net



REVISIONS

DATE	DESCRIPTION
07/15/2020	1

DETAILS

RENEWED MEDICAL  
 OLD NATIONAL HIGHWAY  
 SOUTH FULTON, GA

PROJECT No. 21802-4  
 LAND LOT(S) 132, 133  
 DISTRICT 13TH  
 COUNTY FULTON  
 SCALE N.T.S.  
 DATE 04/09/2020

DRAWING NO.

C-2.2

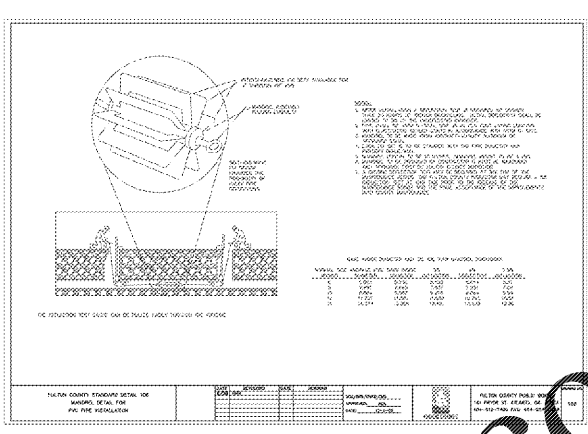

NO.	DESCRIPTION	QUANTITY	UNIT	REMARKS
1	CONCRETE			
2	STEEL REINFORCEMENT			

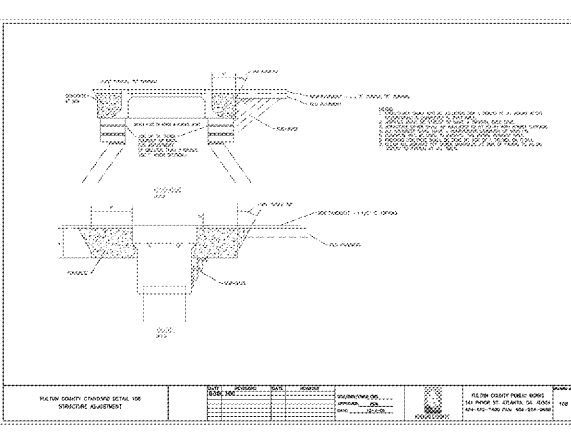

NO.	DESCRIPTION	QUANTITY	UNIT	REMARKS
1	CONCRETE			
2	STEEL REINFORCEMENT			

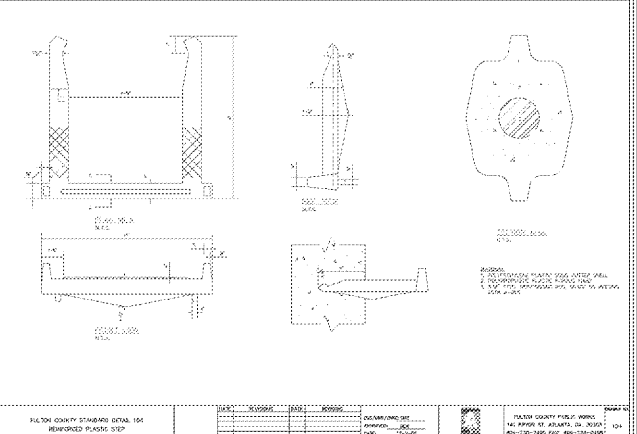

NO.	DESCRIPTION	QUANTITY	UNIT	REMARKS
1	CONCRETE			
2	STEEL REINFORCEMENT			

**ALLOWABLE TRENCH WIDTHS**

DEPTH (ft)	ALLOWABLE WIDTH (ft)
1	12
2	10
3	8
4	6
5	5
6	4
7	3
8	3
9	3
10	3
11	3
12	3
13	3
14	3
15	3
16	3
17	3
18	3
19	3
20	3
21	3
22	3
23	3
24	3
25	3
26	3
27	3
28	3
29	3
30	3

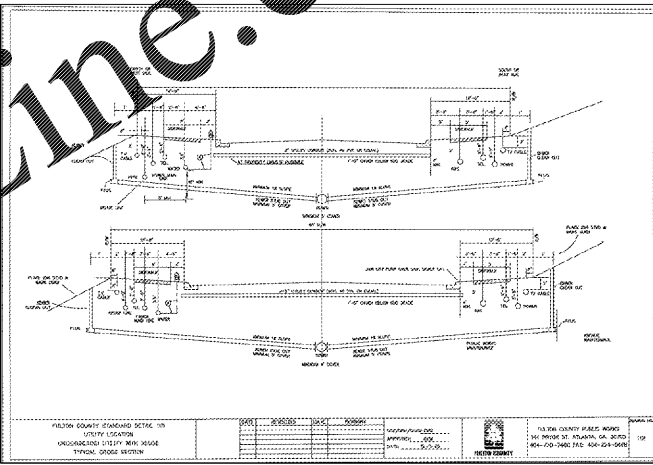

NO.	DESCRIPTION	QUANTITY	UNIT	REMARKS
1	CONCRETE			
2	STEEL REINFORCEMENT			

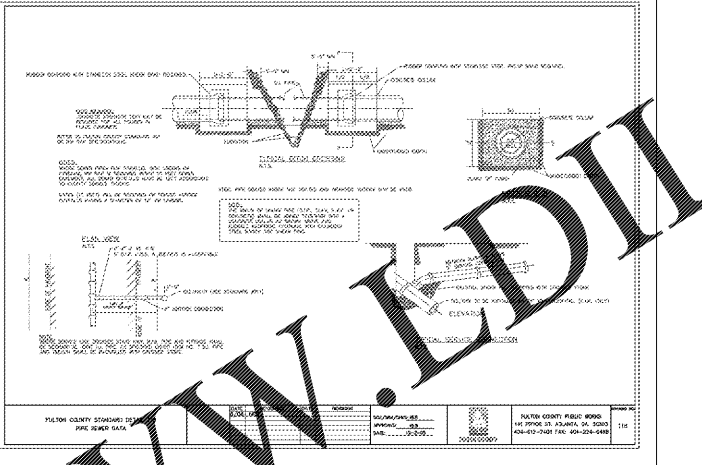

NO.	DESCRIPTION	QUANTITY	UNIT	REMARKS
1	CONCRETE			
2	STEEL REINFORCEMENT			

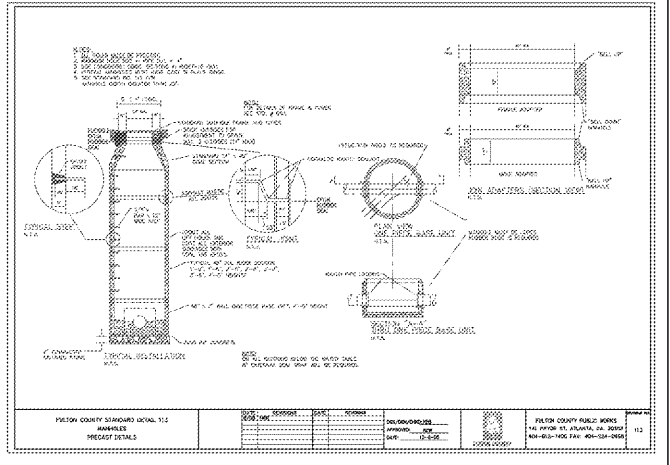

NO.	DESCRIPTION	QUANTITY	UNIT	REMARKS
1	CONCRETE			
2	STEEL REINFORCEMENT			

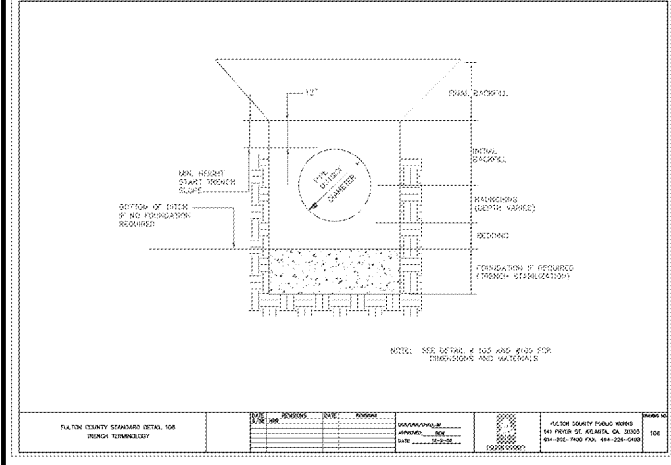

NO.	DESCRIPTION	QUANTITY	UNIT	REMARKS
1	CONCRETE			
2	STEEL REINFORCEMENT			

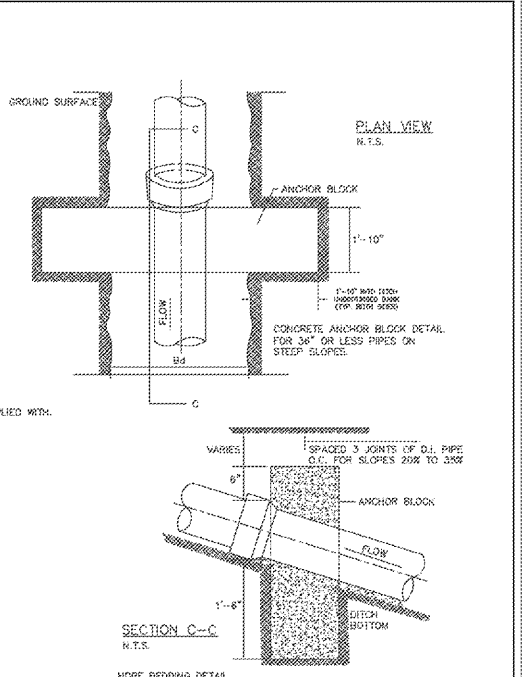

NO.	DESCRIPTION	QUANTITY	UNIT	REMARKS
1	CONCRETE			
2	STEEL REINFORCEMENT			

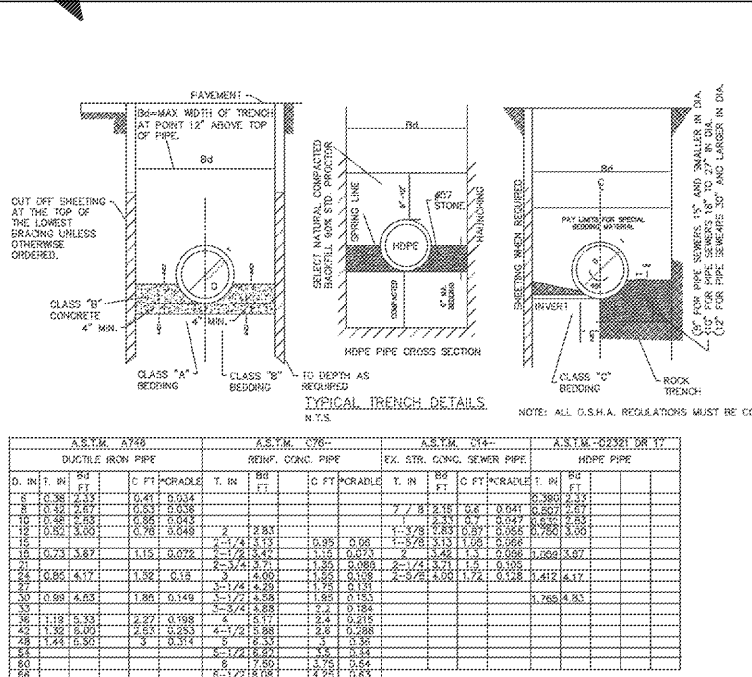

NO.	DESCRIPTION	QUANTITY	UNIT	REMARKS
1	CONCRETE			
2	STEEL REINFORCEMENT			

24 HR CONTACT  
 NAME: PAUL MCKOY  
 PH: (678) 472-3734



DATE	REVISIONS	DATE	REVISIONS
6/06/16	NRR		
7/16	TPM		

DWG./REV./CHKD./REB	APPROVED	DATE
	REW	12-2-05

FULTON COUNTY PUBLIC WORKS  
 141 PRYOR ST. ATLANTA, GA. 30303  
 404-812-7400 FAX: 404-224-0486

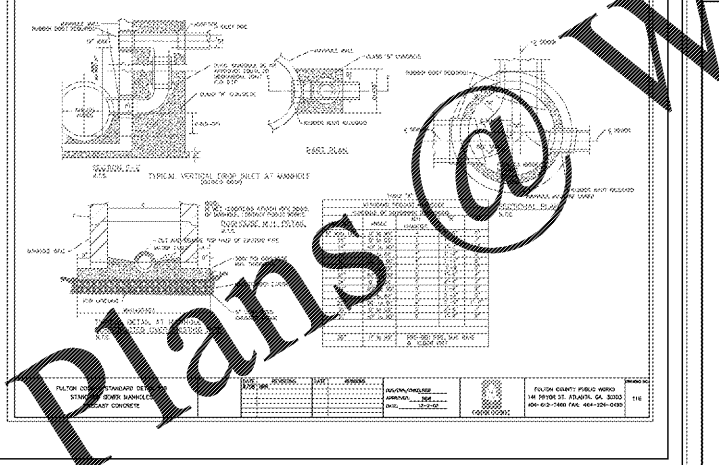

NO.	DESCRIPTION	QUANTITY	UNIT	REMARKS
1	CONCRETE			
2	STEEL REINFORCEMENT			

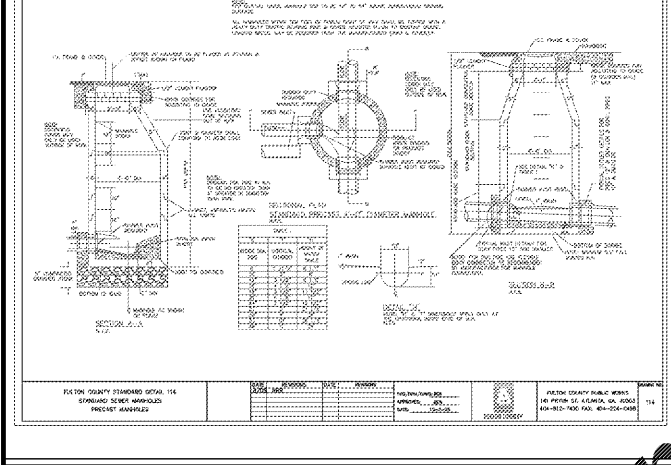

NO.	DESCRIPTION	QUANTITY	UNIT	REMARKS
1	CONCRETE			
2	STEEL REINFORCEMENT			

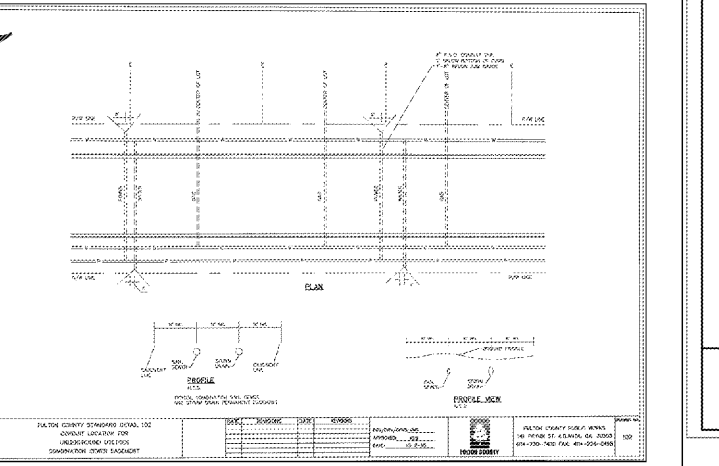

NO.	DESCRIPTION	QUANTITY	UNIT	REMARKS
1	CONCRETE			
2	STEEL REINFORCEMENT			

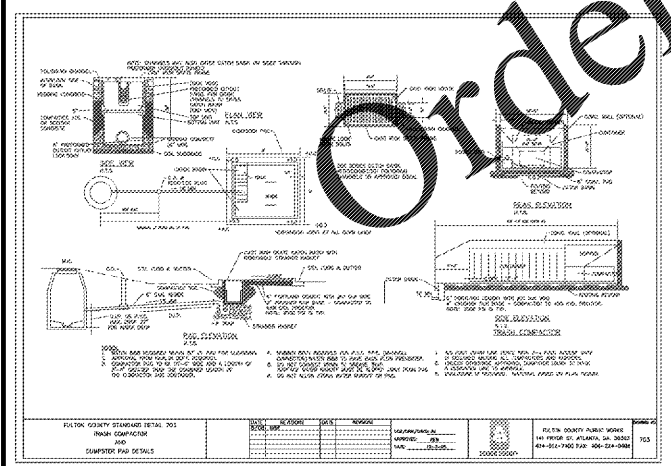

NO.	DESCRIPTION	QUANTITY	UNIT	REMARKS
1	CONCRETE			
2	STEEL REINFORCEMENT			

Order Plans @

U:\URBAN\urba\urba-2018\21802-4 - Renewed Medical\21802-4.dwg  
 04/09/2020 1:17 PM