

1 REMODELED WORK ROOM DETAIL PLAN
A4.06 SCALE: 1/4" = 1'-0"

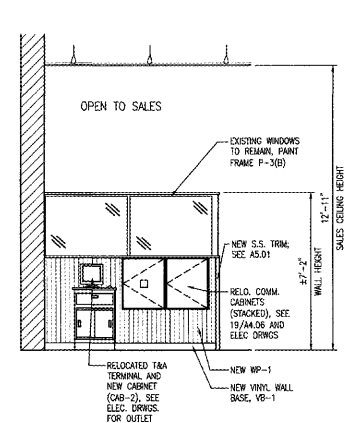

2 REMODELED WORK ROOM ELEVATION
A4.06 SCALE: 1/4" = 1'-0"

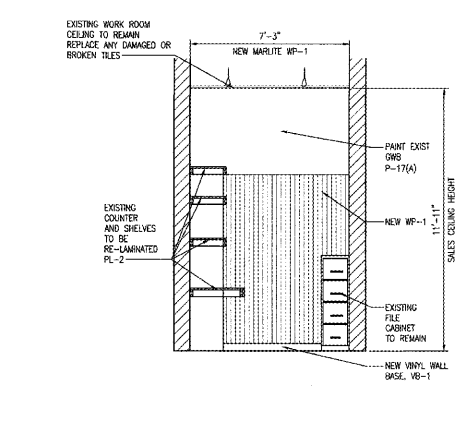

3 REMODELED WORK ROOM ELEVATION
A4.06 SCALE: 1/4" = 1'-0"

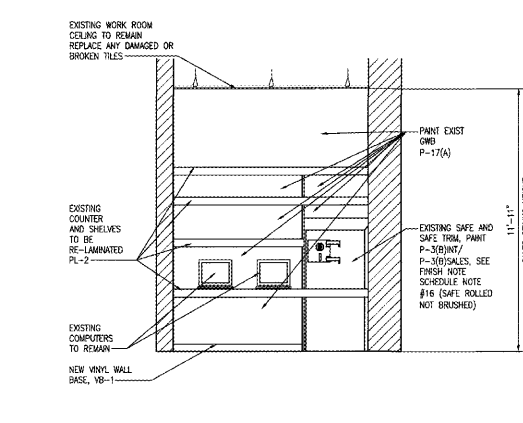

4 REMODELED WORK ROOM ELEVATION
A4.06 SCALE: 1/4" = 1'-0"

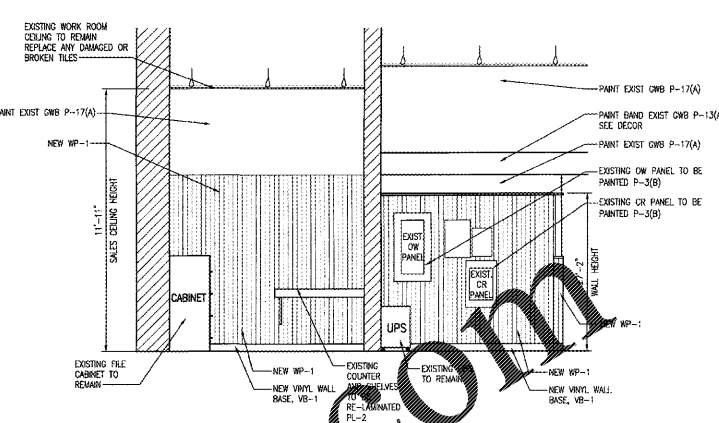

5 REMODELED WORK ROOM ELEVATION
A4.06 SCALE: 1/4" = 1'-0"

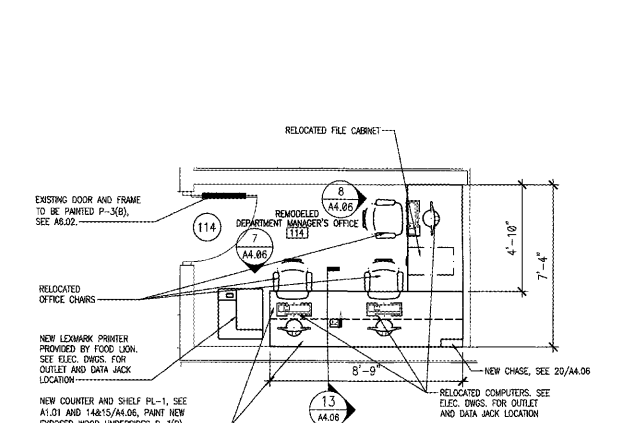

6 REMODELED DEPT. MANAGERS OFFICE DETAIL PLAN
A4.06 SCALE: 1/4" = 1'-0"

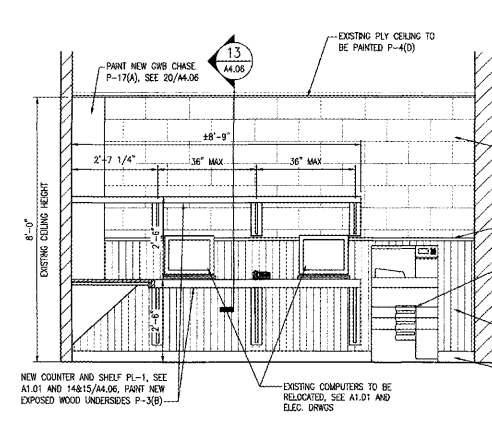

7 REMODELED DEPT. MGR. OFFICE ELEVATION
A4.06 SCALE: 3/8" = 1'-0"

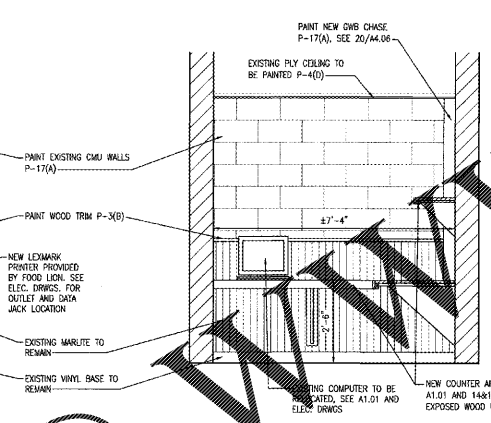

8 REMODELED DEPT. MGR. OFFICE ELEVATION
A4.06 SCALE: 3/8" = 1'-0"

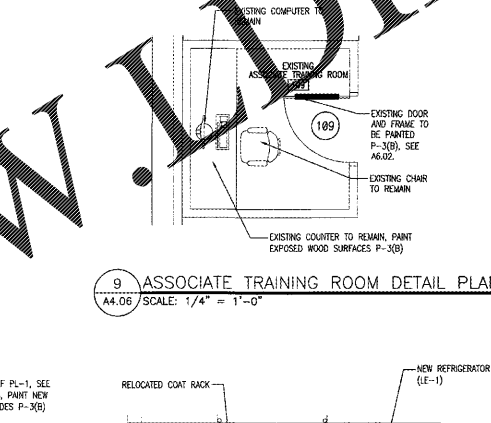

9 ASSOCIATE TRAINING ROOM DETAIL PLAN
A4.06 SCALE: 1/4" = 1'-0"

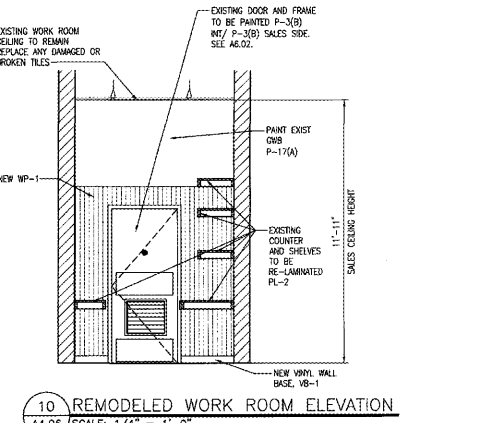

10 REMODELED WORK ROOM ELEVATION
A4.06 SCALE: 1/4" = 1'-0"

11 NOT USED
A4.06

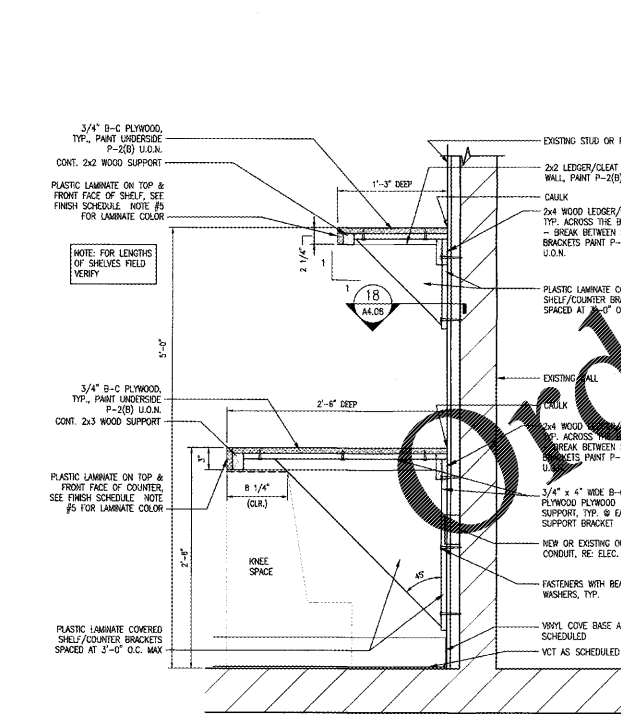

13 SECTION AT COUNTER
A4.06 SCALE: 1" = 1'-0"

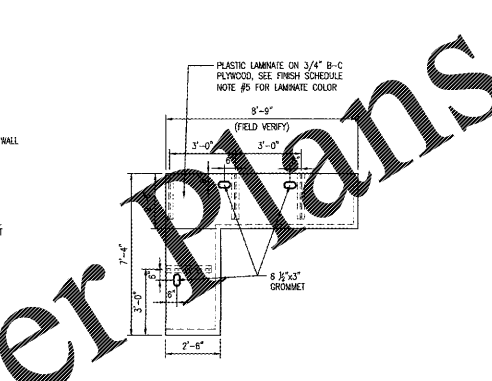

14 DEPT. MGR. OFFICE COUNTER
A4.06 N.T.S.

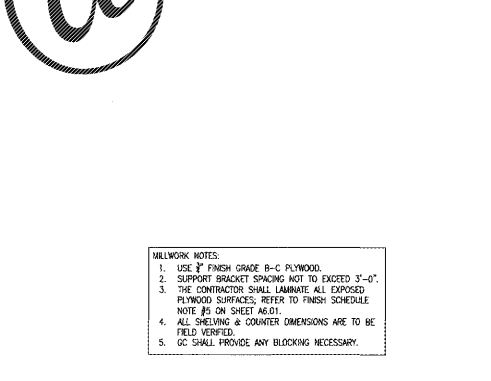

15 DEPT. MGR. OFFICE SHELF
A4.06 N.T.S.

16 NOT USED
A4.06 N.T.S.

17 NOT USED
A4.06 N.T.S.

- MILLWORK NOTES:**
- USE 5/8" FINISH GRADE B-C PLYWOOD.
 - SUPPORT BRACKET SPACING NOT TO EXCEED 3'-0".
 - THE CONTRACTOR SHALL LAMINATE ALL EXPOSED PLYWOOD SURFACES, REFER TO FINISH SCHEDULE NOTE #8 ON SHEET A6.01.
 - ALL SHELVING & COUNTER DIMENSIONS ARE TO BE FIELD VERIFIED.
 - GC SHALL PROVIDE ANY BLOCKING NECESSARY.

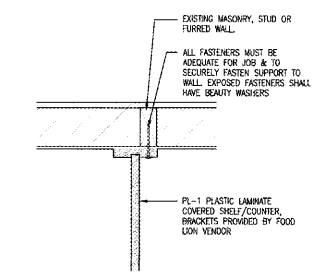

18 SECTION
A4.06 SCALE: 1 1/2" = 1'-0"

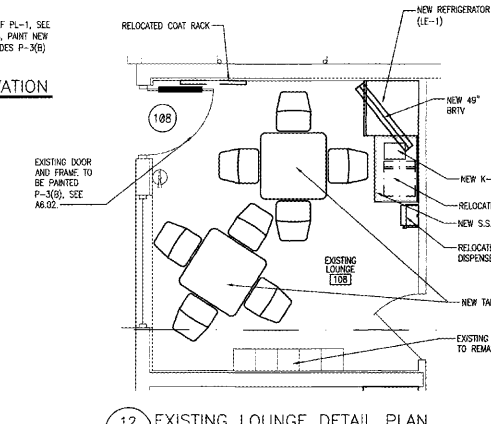

12 EXISTING LOUNGE DETAIL PLAN
A4.06 SCALE: 1/4" = 1'-0"

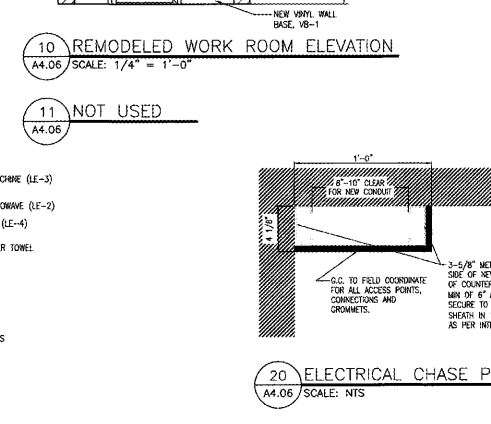

20 ELECTRICAL CHASE PLAN
A4.06 SCALE: NTS

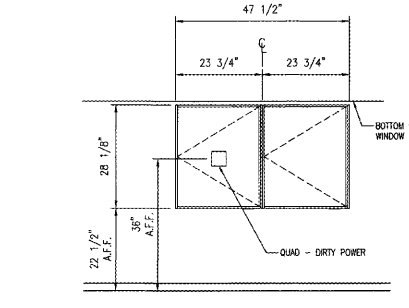

19 COMMUNICATION CABINET INSTALLATION DETAIL
A4.06 N.T.S.

GENERAL NOTES

- ALL EXISTING MARLITE ON SALES FLOOR IS TO BE REMOVED & REPLACED WITH NEW PER FINISH SCHEDULE A6.01. EXISTING MARLITE IN NON-CUSTOMER FACING OFFICES IS TO REMAIN.
- WOOD TRIM AT TOP OF MARLITE IS TO BE REMOVED.
- ALL WOOD TRIM AROUND OPENINGS OR DOORS IS TO BE REMOVED, UNLESS NOTED OTHERWISE.
- ALL SHELVING & COUNTER DIMENSIONS ARE TO BE FIELD VERIFIED.

PRE-FAB CABINETS

CAB-1	DSO CABINET-LYONS-MODEL S350(FRONT), JOHN BOOS-MODEL RDRS3628-FL (BACK)	EXISTING
CAB-2	TBA CABINET-LYONS-MODEL R435	NEW
CAB-3	WORK ROOM CABINET-ROYSTON-MODEL 60082334-153	-
CAB-4	CUSTOMER SERVICE KIOSK 6"-LYONS-MODEL 5577	NEW

LOUNGE EQUIPMENT

LE-1	REFRIGERATOR-FRIGIDAIRE-MODEL #332892	NEW
LE-2	MICROWAVE	RELOCATED
LE-3	COFFEE MAKER-TOUCH ESSENTIALS-MODEL #12148	NEW
LE-4	S.S. TABLE-JOHN BOOS & CO.-MODEL #516RS-2436SSW	NEW

Order Plans @

WWW.LDOnline.com