

NOTE TO TENANT: ADA COUNTERS REQUIRE ADA DISHWASHER. PLEASE VERIFY DIMENSION OF COUNTERS AND CASEWORK PRIOR TO ORDERING APPLIANCES (TYP).

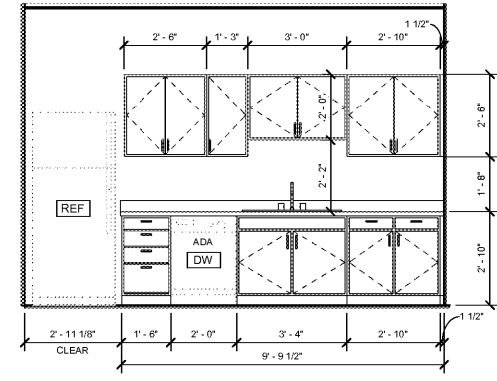

13 BREAK ROOM 139 ELEV
3/8" = 1'-0"

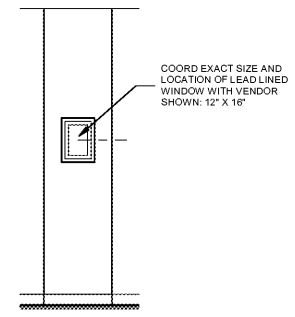

12 X-RAY WINDOW ELEV
3/8" = 1'-0"

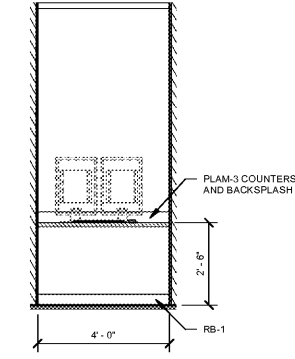

11 X-RAY 118 ELEV
3/8" = 1'-0"

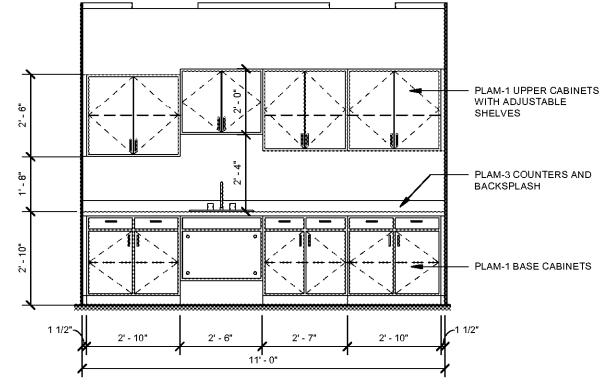

10 CAST 117 ELEV
3/8" = 1'-0"

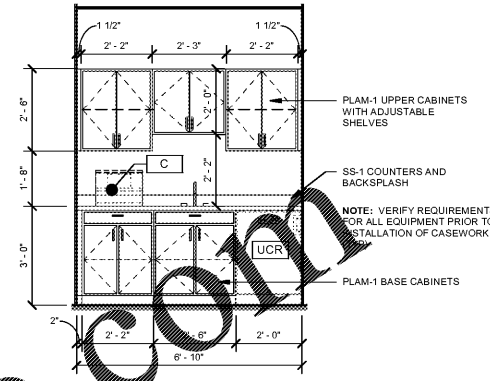

9 LAB 116 ELEV
3/8" = 1'-0"

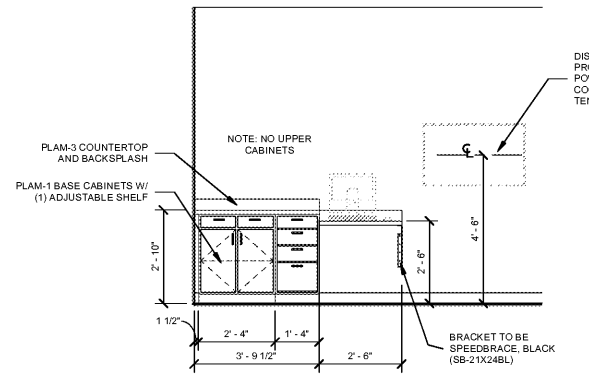

8 LARGE EXAM ROOM ELEV
3/8" = 1'-0"

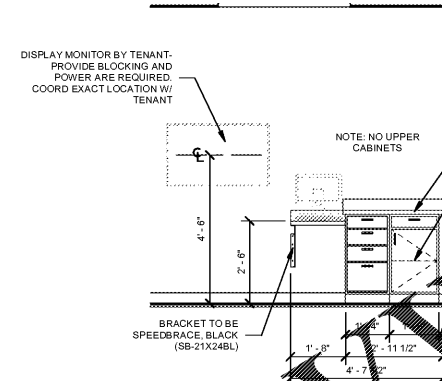

7 TYPICAL EXAM (NO SINK)
3/8" = 1'-0"

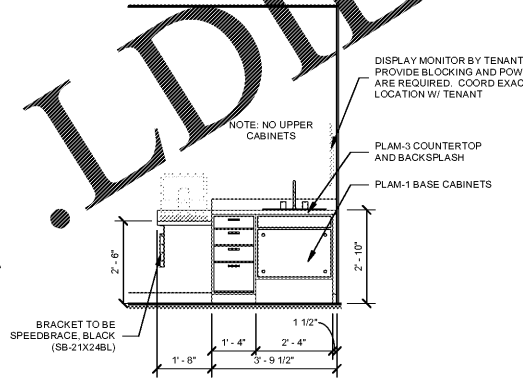

6 TYPICAL EXAM (WITH SINK)
3/8" = 1'-0"

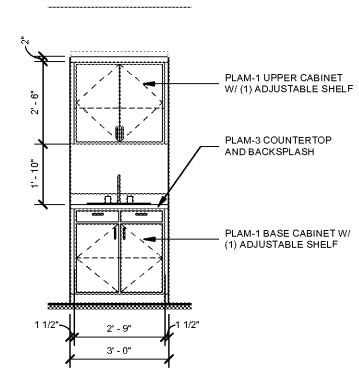

5 TYPICAL HALL HANDWASH STATION
3/8" = 1'-0"

- GENERAL CASEWORK NOTES:**
- WHERE POWER/DATA OCCUR AT KNEE SPACE, LOCATE AT STANDARD HEIGHT AND PROVIDE GROMMETS.
 - WHERE POWER/DATA OCCUR AT BASE CABINETS, MOUNT 8" ABOVE TOP OF BACKSLASH TO CENTERLINE.
 - REVIEW ELECTRICAL IN FIELD AFTER J-BOXES INSTALLED BUT BEFORE CONDUIT/WIRING INSTALLED.
 - PROVIDE BRACKETS AS REQUIRED AT ALL KNEE SPACES. BRACKETS TO BE SPEEDBRACE, BLACK (SB-21X24BL)

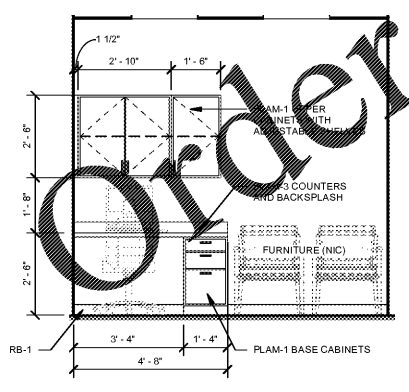

4 SCHEDULING 120 ELEV
3/8" = 1'-0"

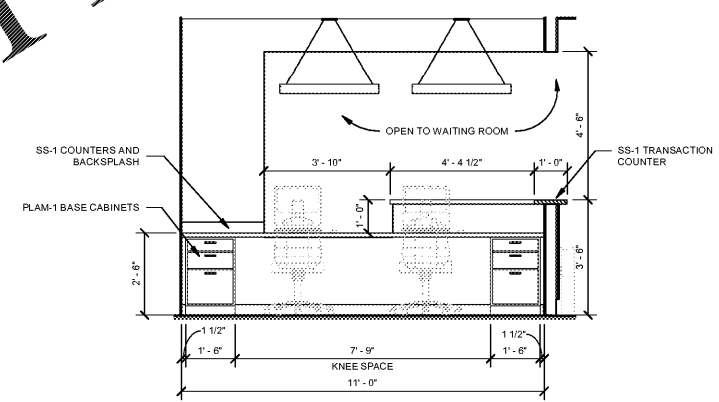

3 RECEPTION 115 ELEV
3/8" = 1'-0"

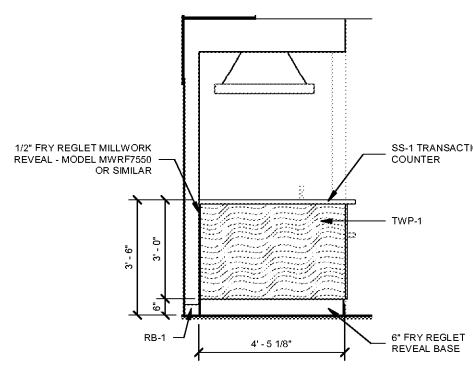

2 WAITING ROOM SIDE ELEV
3/8" = 1'-0"

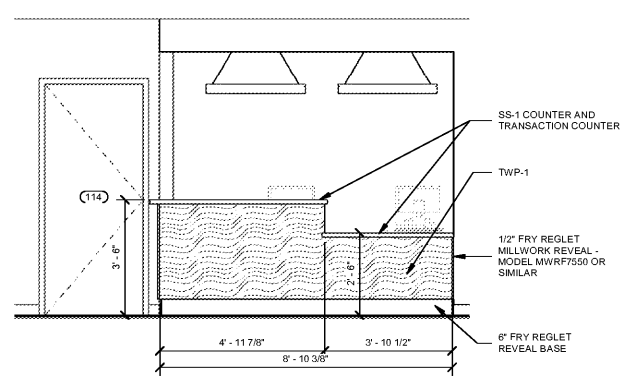

1 WAITING ROOM FRONT ELEV
3/8" = 1'-0"

Order Plans @

WWW.LDILine.com

PRICING SET
NOT FOR
CONSTRUCTION

EXPIRATION DATE:
COPYRIGHT NOTICE
THE DRAWINGS ARE THE PROPERTY OF RIVER STREET ARCHITECTURE LLC. ANY USE, REUSE, REPRODUCTION, DISPLAY OR SALE OF THESE DRAWINGS WITHOUT THE EXPRESS WRITTEN CONSENT OF THE ARCHITECT IS STRICTLY PROHIBITED.

river street
ARCHITECTURE
123 E 7th street, suite 400 chattanooga, tennessee 37402
P-423 634 0806 www.riverstreetarchitecture.com

DRS. BRUCE & SMITH MEDICAL OFFICES
ORTHOPEDIC OFFICES
1ST FLOOR
RIVERFRONT PARKWAY
CHATTANOOGA, TN 37402

Revision Schedule		
Rev. #	Rev. Date	Revision Description

Release Date: 05.10.2020
Project No.: 20021

INTERIOR ELEVATIONS

A2.01

5/11/2020 1:59:14 PM