

**1** FOOTING STEP ELEVATION  
S3.1 SCALE: 3/4" = 1'-0"

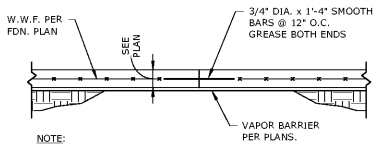

**2** TYPICAL SLAB JOINTS  
S3.1 SCALE: 3/4" = 1'-0"

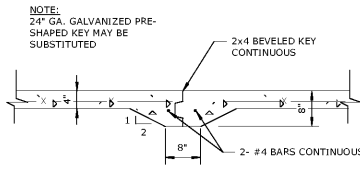

**3** TYP. ALT. FLOOR SLAB CONSTR. JT.  
S3.1 SCALE: 3/4" = 1'-0"

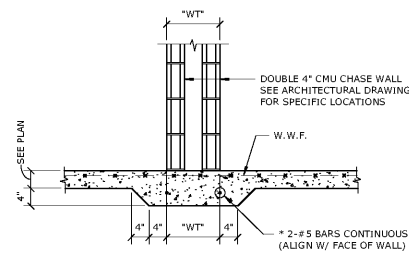

**4** TYPICAL THICKENED SLAB SECTION  
S3.1 SCALE: 3/4" = 1'-0"

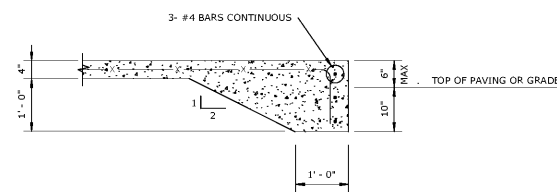

**5** TYPICAL TURNED DOWN SLAB DETAIL  
S3.1 SCALE: 3/4" = 1'-0"

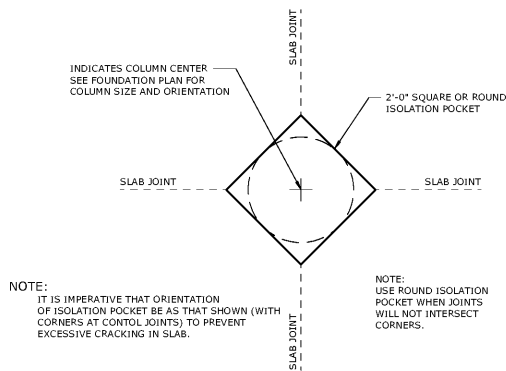

**6** ISOLATION POCKET DETAIL  
S3.1 SCALE: 3/4" = 1'-0"

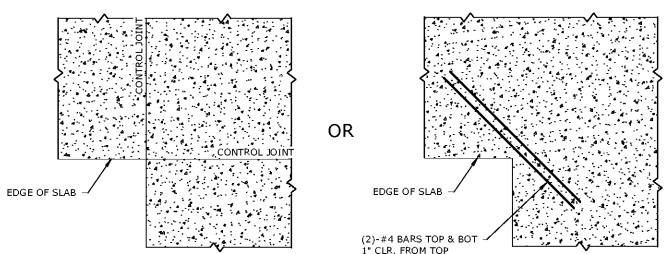

**7** RE-ENTRANT CORNER  
S3.1 SCALE: 3/4" = 1'-0"

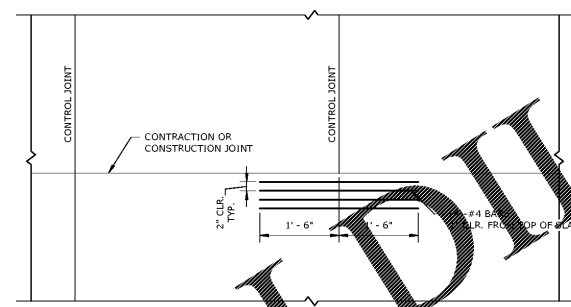

**8** DISCONTINUOUS JOINT PLAN DETAIL  
S3.1 SCALE: 3/4" = 1'-0"

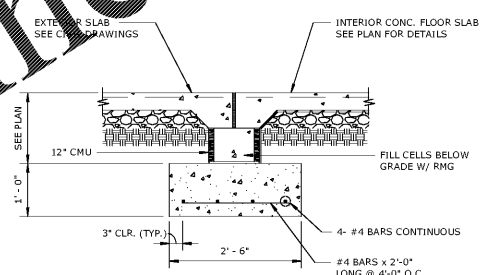

**9** TYP. ENTRY SECTION  
S3.1 SCALE: 3/4" = 1'-0"

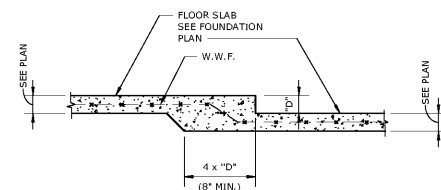

**10** TYPICAL DEPRESSED SLAB DETAIL  
S3.1 SCALE: 3/4" = 1'-0"

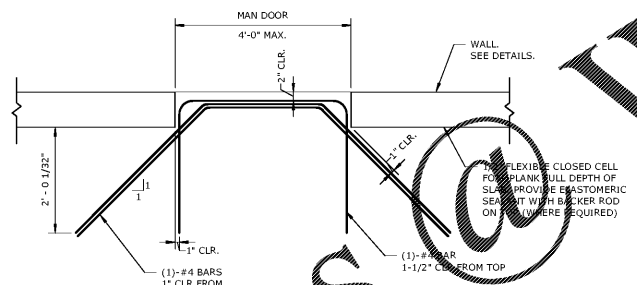

**11** MAN DOOR SLAB REINFORCEMENT  
S3.1 SCALE: 3/4" = 1'-0"

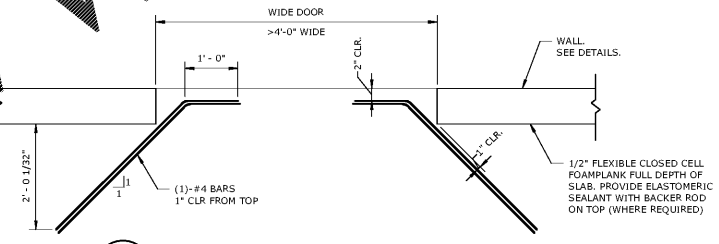

**12** WIDE DOOR SLAB REINFORCEMENT  
S3.1 SCALE: 3/4" = 1'-0"

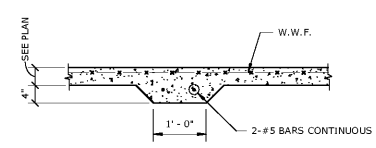

**13** THICKENED SLAB  
S3.1 SCALE: 3/4" = 1'-0"

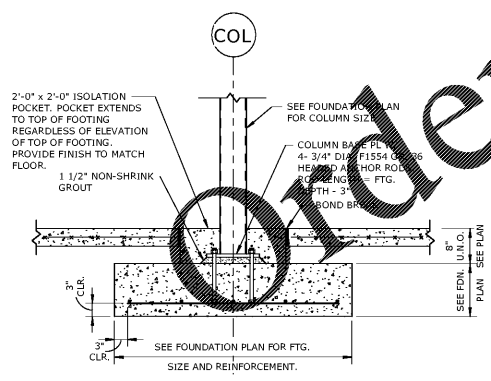

**14** TYPICAL SECTION @ INTERIOR COLUMN  
S3.1 SCALE: 3/4" = 1'-0"

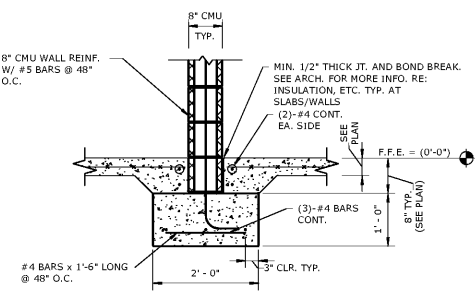

**15** SECTION @ INTERIOR SHEAR WALLS  
S3.1 SCALE: 3/4" = 1'-0"

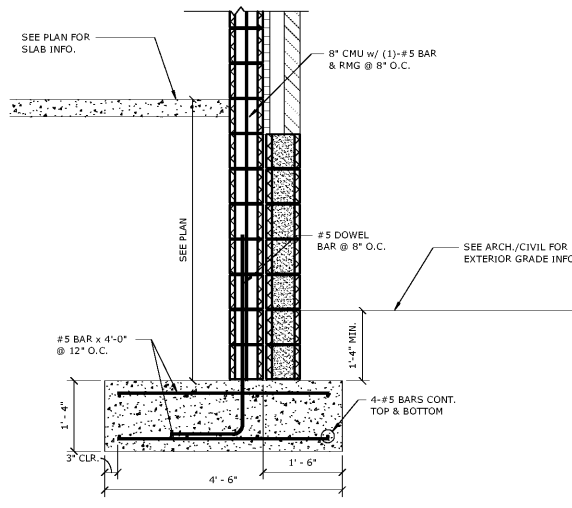

**16** FOUNDATION WALL  
S3.1 SCALE: 3/4" = 1'-0"

NO.	DESCRIPTION	DATE

**RUSSOM ELEMENTARY SCHOOL ADDITION**  
**44 RUSSOM ELEMENTARY SCHOOL LANE**  
**DALLAS, GA 30132**  
 (FACILITY CODE: 710-0204)

**PAULDING COUNTY SCHOOLS**

**FOUNDATION SECTIONS**

DATE 03/06/2020  
 PROJECT NO. 19117

**S3.1**

**BXA**  
**Breaux & Associates**  
 ARCHITECTS

5965 Shiloh Road East, Suite 300  
 Alpharetta, Georgia 30005 | (678) 565-4508



PRINTED BY: GEORGIA ASSOCIATION OF ARCHITECTS  
 201 - 520-6600  
 100 Peachtree Street, N.E.  
 Atlanta, Georgia 30308  
 03/06/2020

104372 SF S.F. (EXISTING AREA) + 22878 SF S.F. (NEW AREA) = 127250 SF (TOTAL AREA) • 800 F.T.E. (EXISTING) + 250 F.T.E. (NEW) = 1050 F.T.E. (TOTAL) • 56 I.U. (EXISTING) + 17 I.U. (NEW) = 73 I.U. (TOTAL)