

**DOWNSPOUT COLLECTOR
ADAPTER DETAIL**
(NOT TO SCALE)

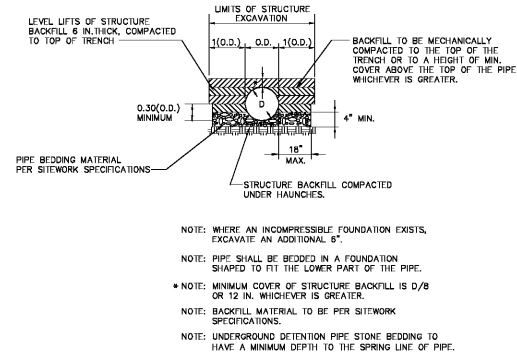

STORM SEWER TRENCHING & BACKFILLING
(NOT TO SCALE)

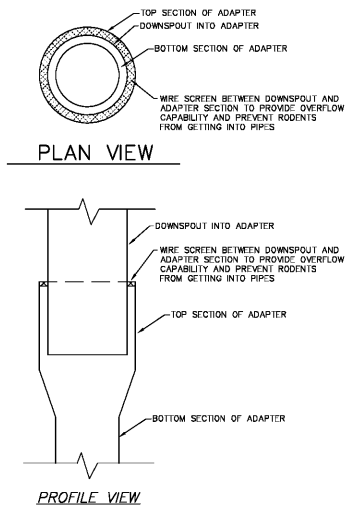
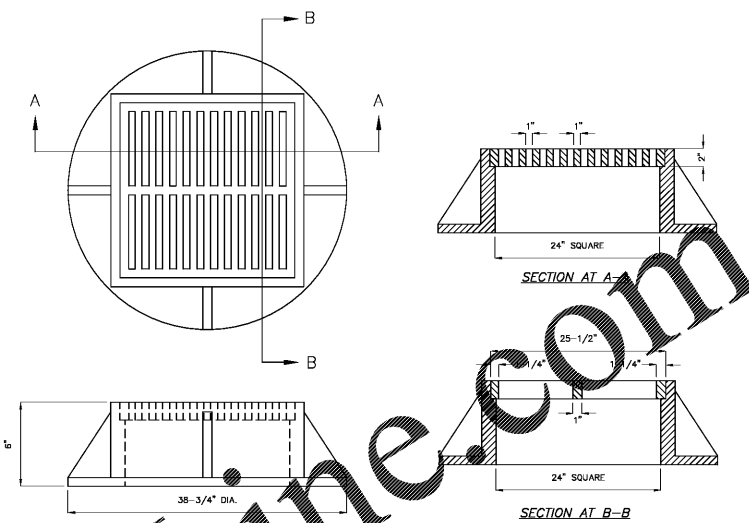

INLET GRATE & FRAME DETAIL
NENAH TYPE R-3339-A
(NOT TO SCALE)

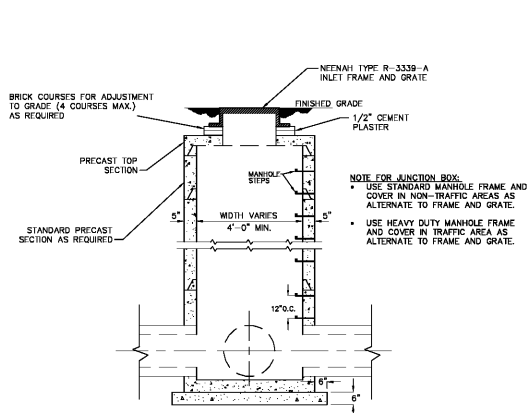

PRECAST DROP INLET & JUNCTION BOX DETAIL
(NOT TO SCALE)

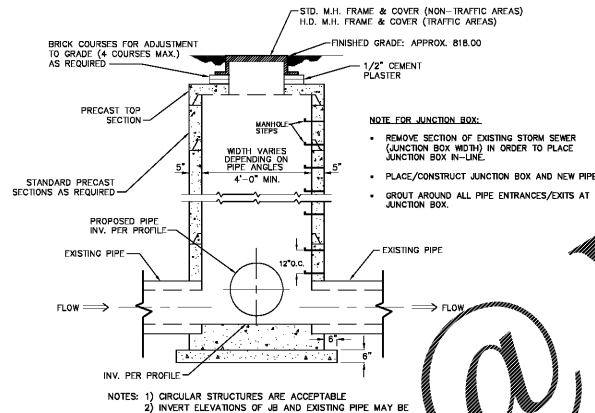

DOGHOUSE MANHOLE DETAIL
(NOT TO SCALE)

BXA
Breux & Associates
ARCHITECTS
5965 Shiloh Road East, Suite 200
Alpharetta, Georgia 30005 | (678) 565-4508

REGISTERED PROFESSIONAL ENGINEER
3/08/20

HGA
HAINES GIPSON & ASSOCIATES
Civil • Structural • Bridge

NO.	DESCRIPTION	REV.

RUSSOM ELEMENTARY SCHOOL ADDITION
44 RUSSOM ELEMENTARY SCHOOL LANE
DALLAS, GA 30132
(FACILITY CODE: 710-0204)

PAULDING COUNTY SCHOOLS

GRADING DETAILS

Date 03/06/2020
Project Number 19117

C6.2

GRADING DETAILS