

STATUS	BY	APPROVED	DATE	MACON WATER AUTHORITY STANDARD DETAILS	RECOMMENDED BY THE MACON WATER AUTHORITY ENGINEERING DEPT.
ORIGINAL					
REVISION					
PRECAST CONCRETE MANHOLE DETAIL					
N.T.S.				DRAWING NUMBER	S-2

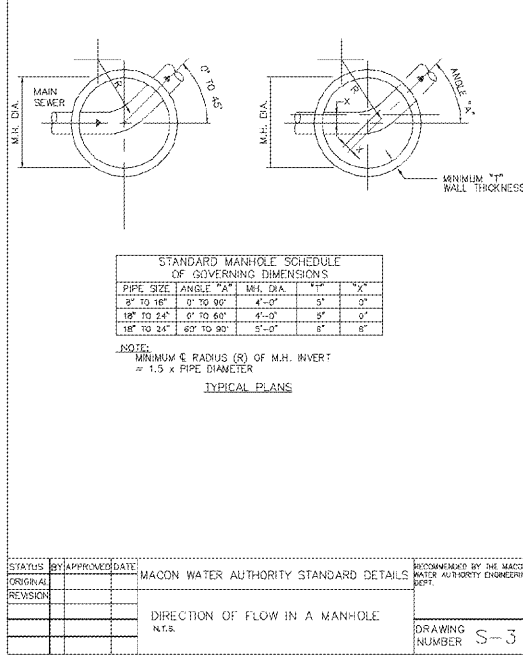

STATUS	BY	APPROVED	DATE	MACON WATER AUTHORITY STANDARD DETAILS	RECOMMENDED BY THE MACON WATER AUTHORITY ENGINEERING DEPT.
ORIGINAL					
REVISION					
DIRECTION OF FLOW IN A MANHOLE					
N.T.S.				DRAWING NUMBER	S-3

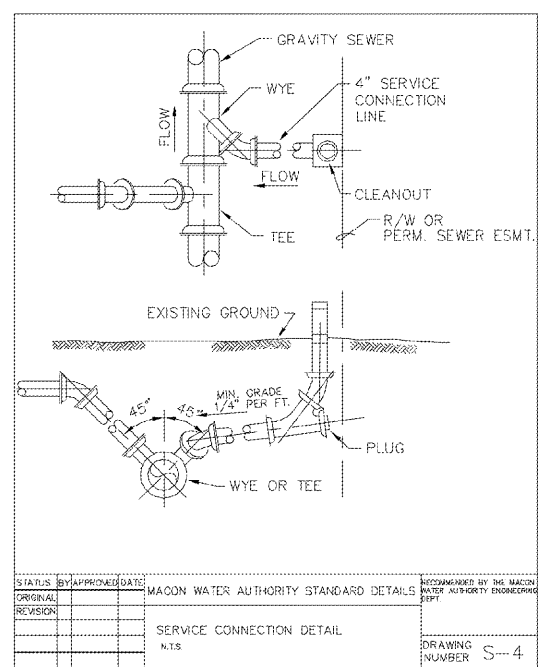

STATUS	BY	APPROVED	DATE	MACON WATER AUTHORITY STANDARD DETAILS	RECOMMENDED BY THE MACON WATER AUTHORITY ENGINEERING DEPT.
ORIGINAL					
REVISION					
SERVICE CONNECTION DETAIL					
N.T.S.				DRAWING NUMBER	S-4

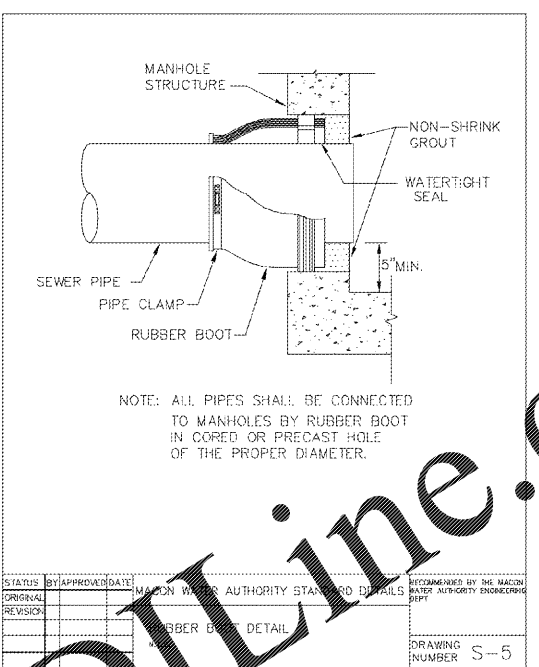

STATUS	BY	APPROVED	DATE	MACON WATER AUTHORITY STANDARD DETAILS	RECOMMENDED BY THE MACON WATER AUTHORITY ENGINEERING DEPT.
ORIGINAL					
REVISION					
RUBBER BOOT DETAIL					
N.T.S.				DRAWING NUMBER	S-5

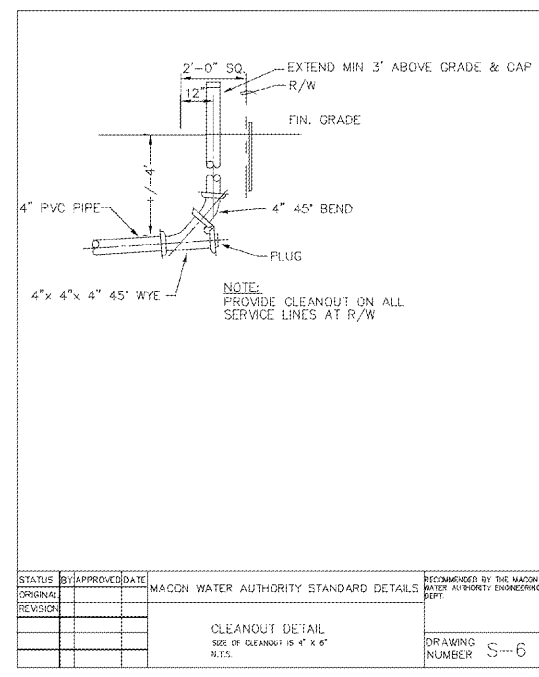

STATUS	BY	APPROVED	DATE	MACON WATER AUTHORITY STANDARD DETAILS	RECOMMENDED BY THE MACON WATER AUTHORITY ENGINEERING DEPT.
ORIGINAL					
REVISION					
CLEANOUT DETAIL					
SIZE OF CLEANOUT IS 4\"/>					
N.T.S.				DRAWING NUMBER	S-6

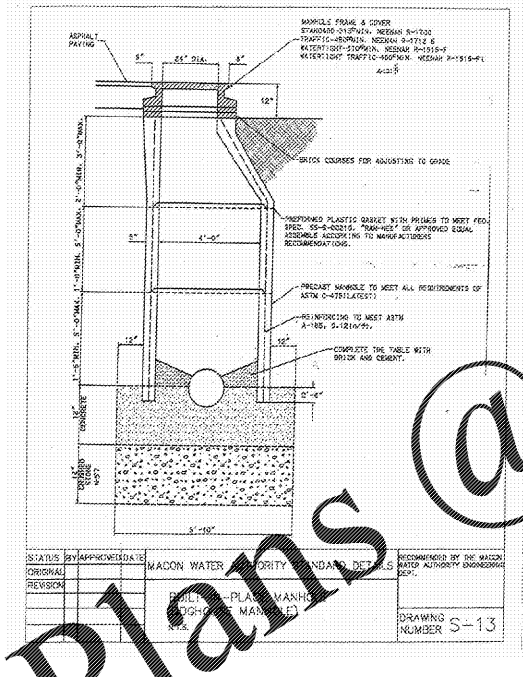

STATUS	BY	APPROVED	DATE	MACON WATER AUTHORITY STANDARD DETAILS	RECOMMENDED BY THE MACON WATER AUTHORITY ENGINEERING DEPT.
ORIGINAL					
REVISION					
MANHOLE FRAME & COVER					
N.T.S.				DRAWING NUMBER	S-13

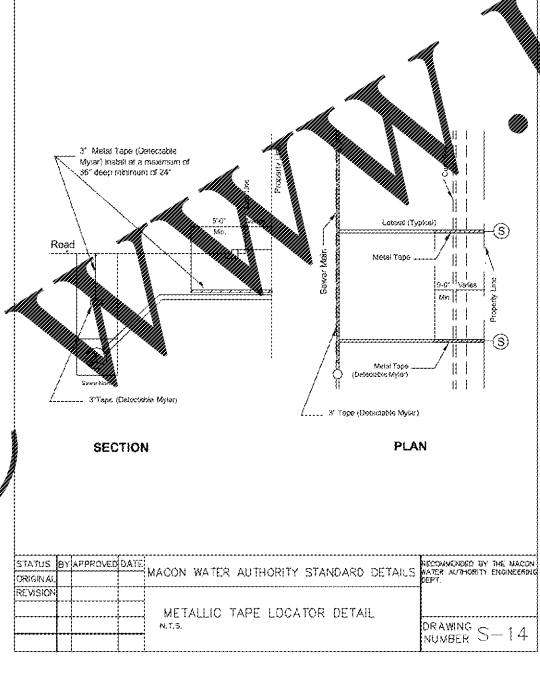

STATUS	BY	APPROVED	DATE	MACON WATER AUTHORITY STANDARD DETAILS	RECOMMENDED BY THE MACON WATER AUTHORITY ENGINEERING DEPT.
ORIGINAL					
REVISION					
METALLIC TAPE LOCATOR DETAIL					
N.T.S.				DRAWING NUMBER	S-14

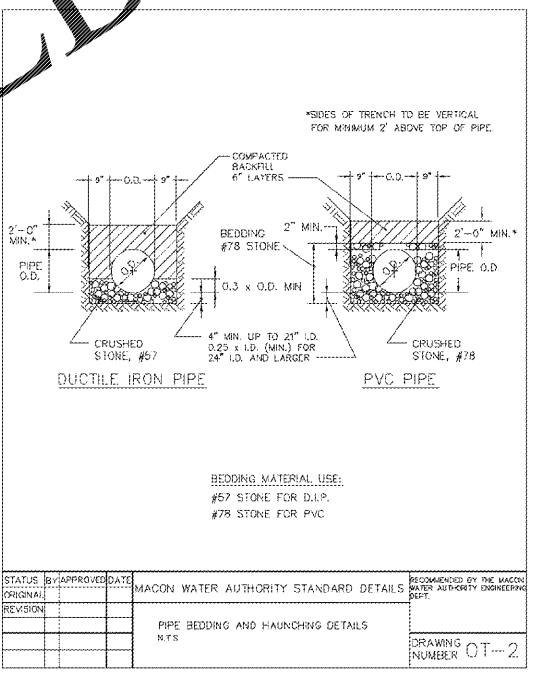

STATUS	BY	APPROVED	DATE	MACON WATER AUTHORITY STANDARD DETAILS	RECOMMENDED BY THE MACON WATER AUTHORITY ENGINEERING DEPT.
ORIGINAL					
REVISION					
PIPE BEDDING AND HAUNCHING DETAILS					
N.T.S.				DRAWING NUMBER	OT-2

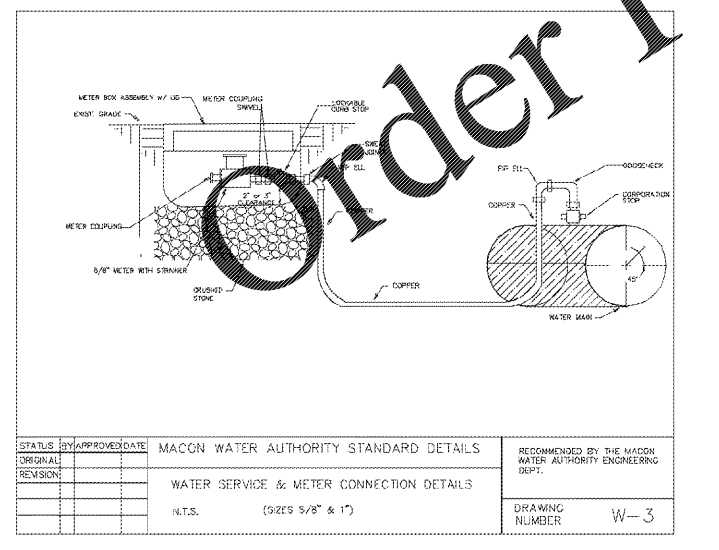

STATUS	BY	APPROVED	DATE	MACON WATER AUTHORITY STANDARD DETAILS	RECOMMENDED BY THE MACON WATER AUTHORITY ENGINEERING DEPT.
ORIGINAL					
REVISION					
WATER SERVICE & METER CONNECTION DETAILS					
N.T.S. (SIZES 5/8\"/>					
				DRAWING NUMBER	W-3

ISSUED FOR REVIEW  
January 14, 2020

REEVES DESIGN  
Services, LLC • Consulting Engineers  
4875 RIVERSIDE DRIVE / SUITE 107  
MACON, GEORGIA 31210  
478.747.6772  
www.reevesdesign.net

Project #: 1819 Date: 01/13/20

C14

DUNWODY/BEELEND,  
architects, inc.  
200  
Mableton, Georgia 30128  
T 404.743.8281  
F 404.743.8285

Dunwody/Beelend, Architects, Inc.  
This drawing may be utilized only for the purpose of constructing or installing the work shown thereon at the site of the work specified. Any other use of this drawing, including without limitation any reproduction or alteration of the drawing, without prior written approval of Dunwody/Beelend, Architects, Inc. is prohibited.

FACILITY IMPROVEMENTS  
AT TOBESOFKEE PARKS  
FOR MACON-BIBB COUNTY  
MOSLEY DIXON ROAD MACON, GEORGIA

Revisions:	

Sheet Title:  
MWA UTILITY DETAILS