

PARKING TABULATION	
REQUIRED PARKING = 1 PER 125 SQ. FT.	21
TOTAL REQUIRED PARKING	21
TOTAL PROVIDED PARKING	24
H/C ACCESSIBLE REQUIRED	2
H/C ACCESSIBLE PROVIDED	2

- SITE NOTES:**
- G.C. SHALL FOLLOW RECOMMENDATIONS OF GEOTECHNICAL ENGINEERING REPORT FOR PREPARATION OF SITE AND PARKING SUBGRADE.
 - REFER TO STRUCTURAL NOTES FOR BUILDING SLAB SITE PREPARATION
 - G.C. SHALL HIRE A STATE LICENSED IRRIGATION CONTRACTOR FOR THE INSTALLATION OF IRRIGATION SYSTEM.
 - G.C. SHALL INSURE THAT THE WALK AT EXTERIOR DOORS IS A MAXIMUM OF 1:50 AT ACCESSIBLE APPROACHES AND 1:50 CROSS SLOPE.
 - G.C. SHALL INSURE THAT ALL ACCESSIBLE ROUTES ARE A MAXIMUM OF 1:20 SLOPE.
 - SLOPE AT ACCESSIBLE PARKING AND ACCESS AISLES SHALL NOT EXCEED 1:50 SLOPE AND CROSS SLOPE.
 - PROVIDE JUNCTION BOX AT DUMPSTER ENCLOSURE FOR IRRIGATION CONTRACTOR TO HARDWIRE SPRINKLER CONTROLLER.
 - THE SPRINKLER SYSTEM SHALL HAVE A FROST AND RAIN DETECTOR.
 - NO EXTERIOR CONDUITS ARE TO BE RUN UNDER THE BUILDING.

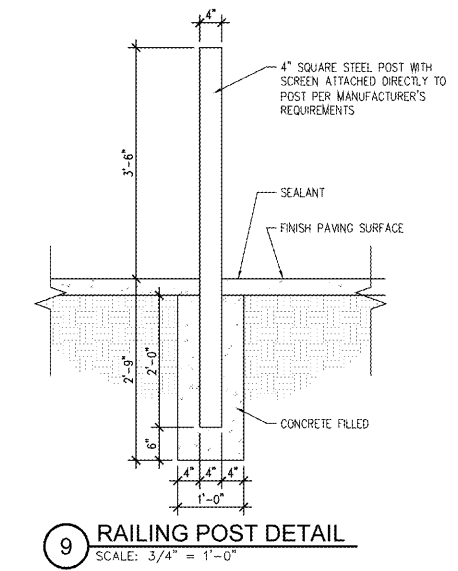
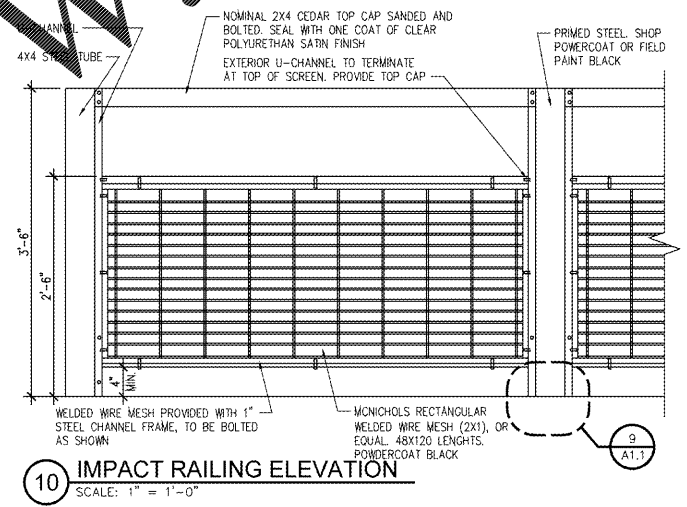
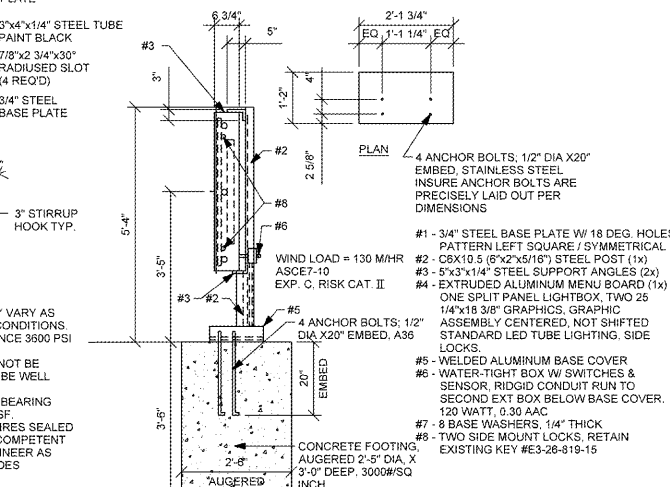
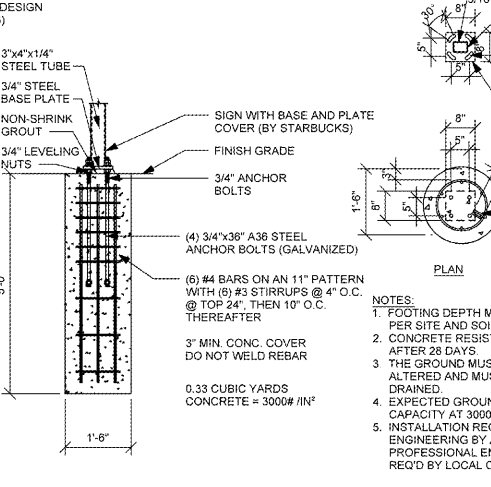
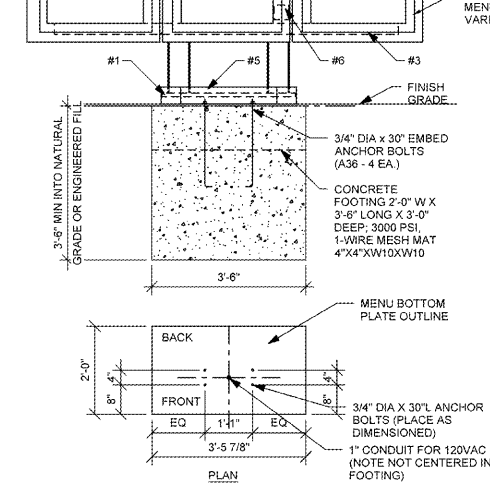
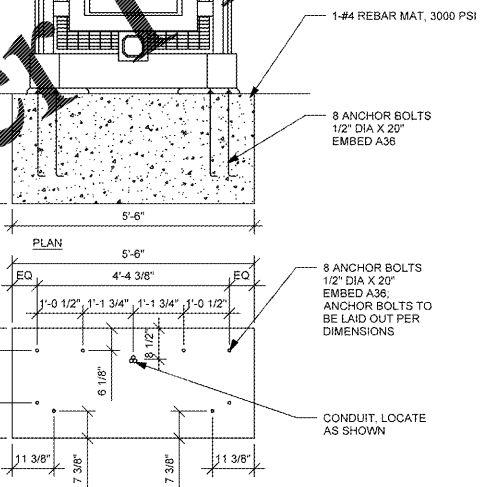
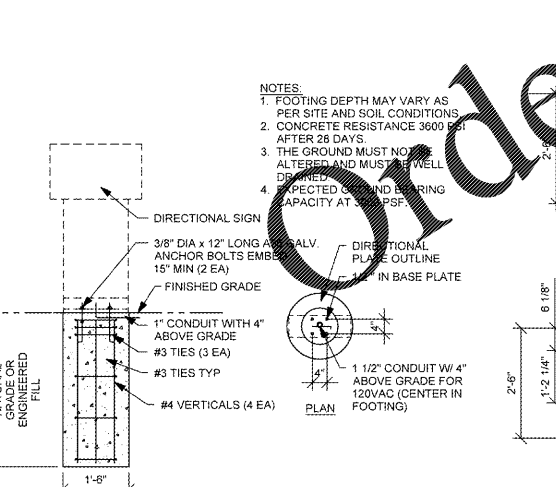
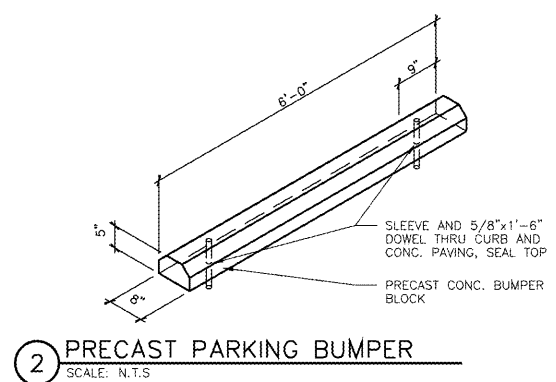
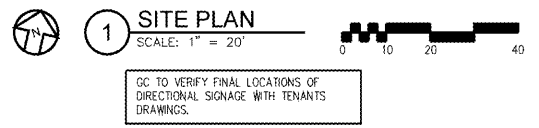

www.LDILLINE.com