

EXISTING SIGNAGE SCHEDULE

SIGNAGE LOCATION	QTY	LIGHTED	COLOR	SIZE	AREA (SF)	TOTAL AREA (SF)
<b>FRONT SIGNAGE</b>						
Walmart (Spark)	1	LED	WHITE/YELLOW	9'-6"	298.00 SF	298.00 SF
Walmart (Spark)	1	LED	WHITE/YELLOW	9'-6"	298.00 SF	298.00 SF
Pickup (Spark) (ETR)	1	LED	YELLOW/WHITE	2'-6"	65.43 SF	65.43 SF
Home & Pharmacy	1	N/A	WHITE	2'-0"	61.85 SF	61.85 SF
Market	1	N/A	WHITE	2'-0"	17.57 SF	17.57 SF
Outdoor Living	1	N/A	WHITE	2'-0"	45.47 SF	45.47 SF
Auto Center >	1	N/A	WHITE	1'-8"	19.47 SF	19.47 SF
<b>FRONT SIGNAGE</b>					<b>912.19 SF</b>	<b>912.19 SF</b>
<b>AUTO CENTER SIGNAGE</b>						
Auto Center	1	N/A	WHITE	1'-6"	17.75 SF	17.75 SF
Lube	2	N/A	WHITE	1'-0"	3.13 SF	6.26 SF
Tire	2	N/A	WHITE	1'-0"	2.38 SF	4.76 SF
<b>AUTO CENTER SIGNAGE</b>					<b>28.77 SF</b>	<b>28.77 SF</b>
<b>TOTAL BUILDING SIGNAGE</b>					<b>940.96 SF</b>	<b>940.96 SF</b>

NEW SIGNAGE SCHEDULE

SIGNAGE LOCATION	QTY	LIGHTED	COLOR	SIZE	AREA (SF)	TOTAL AREA (SF)
<b>FRONT SIGNAGE</b>						
Walmart (Spark)	1	LED	WHITE/YELLOW	9'-6"	298.04 SF	298.04 SF
Walmart (Spark)	1	LED	WHITE/YELLOW	9'-6"	298.04 SF	298.04 SF
Pickup (Spark) (ETR)	1	LED	YELLOW/WHITE	2'-6"	65.43 SF	65.43 SF
Home & Pharmacy	1	N/A	WHITE	2'-0"	61.85 SF	61.85 SF
Market	1	N/A	WHITE	2'-0"	17.57 SF	17.57 SF
Outdoor Living	1	N/A	WHITE	2'-0"	37.34 SF	37.34 SF
Auto Center >	1	N/A	WHITE	1'-6"	18.03 SF	18.03 SF
Auto Center >	1	N/A	WHITE	1'-6"	8.49 SF	8.49 SF
<b>FRONT SIGNAGE</b>					<b>516.34 SF</b>	<b>516.34 SF</b>
<b>AUTO CENTER SIGNAGE</b>						
Auto Center	1	N/A	WHITE	1'-6"	17.23 SF	17.23 SF
Lube	2	N/A	WHITE	1'-0"	2.88 SF	5.76 SF
Tire	2	N/A	WHITE	1'-0"	2.58 SF	5.16 SF
<b>AUTO CENTER SIGNAGE</b>					<b>28.35 SF</b>	<b>28.35 SF</b>
<b>TOTAL BUILDING SIGNAGE</b>					<b>544.69 SF</b>	<b>544.69 SF</b>

DEMOLITION NOTES

- REMOVE ALL UNLIT EXTERIOR STUD MOUNTED BUILDING SIGNS
- REMOVAL OF LIT ID/LOGO SIGNS SHALL BE BY OTHERS
- NOT USED
- NOT USED
- REMOVE VISION CENTER CANOPY
- REMOVAL OF BUILDING MOUNTED ITEMS, SHOWN OR NOTED TO BE DEMOLISHED OR AS REQUIRED BY CONTRACTOR SHALL OCCUR PRIOR TO PAINTING BUILDING. COORDINATE DEMOLITION WORK SO EXTERIOR PAINTING WILL OCCUR PRIOR TO INSTALLATION OF BUILDING MOUNTED ITEMS.

SIGNAGE GENERAL NOTES

- SIGNAGE FURNISHED BY WAL-MART AND INSTALLED BY OTHERS
- ALL EXISTING WALMART EXTERIOR SIGNAGE IS TO REMAIN IN PLACE ON THE BUILDING UNTIL THE EXTERIOR SIGN COMPANY IS ON SITE. THE EXTERIOR SIGN COMPANY WILL REMOVE EXISTING SIGNAGE AND INSTALL NEW SIGNAGE. ONCE NEW SIGNAGE IS INSTALLED, GENERAL CONTRACTOR WILL PERFORM PATCH, REPAIR, AND PAINTING WORK NOTED IN PLANS AFTER NEW SIGNAGE IS INSTALLED
- FOR STORES THAT REQUIRE STRUCTURAL MODIFICATIONS OR REPAIRS FOR INSTALLATION OF NEW EXTERIOR SIGNAGE, A TEMPORARY BANNER WILL BE INSTALLED BY THE EXTERIOR SIGN COMPANY PRIOR TO REMOVAL OF EXISTING EXTERIOR SIGNAGE. BANNER WILL REMAIN IN PLACE UNTIL ALL MODIFICATIONS AND/OR REPAIRS HAVE BEEN COMPLETED AND NEW SIGNAGE IS INSTALLED. GC SHALL PRIORITIZE MODIFICATIONS/REPAIRS REQUIRED FOR INSTALLATION OF NEW EXTERIOR SIGNS WHILE EXTERIOR SIGN COMPANY IS ON SITE
- TEMPORARY BANNER WILL BE APPROXIMATELY 125 SF (9'X27')
- EXTERIOR SIGN WORK NEEDS TO BE SCHEDULED, COORDINATED AND COMPLETED DURING WEEK 6 OF THE CONSTRUCTION SCHEDULE.
- GENERAL CONTRACTOR RESPONSIBILITIES
  - REMOVE EXISTING EXTERIOR BUILDING SIGNAGE AS NOTED ON SHEET A2 (LIGHTED ID/LOGO SIGNS WILL BE REMOVED BY OTHERS)
  - BY END OF FIRST WEEK OF CONSTRUCTION REVIEW EXISTING CONSTRUCTION WHERE SIGNS) WILL BE INSTALLED. IF EXISTING CONDITIONS DO NOT MATCH SIGN ATTACHMENT DETAILS SHOWN, REQUEST APPROVAL FROM CONSTRUCTION MANAGER TO SUBMIT RFI IN ACCORDANCE WITH SECTION 01255. NOTE DIFFERENCES IN CONSTRUCTION, INCLUDING DIMENSIONS, AND INCLUDE PHOTOGRAPHS FOR CLARIFICATION OF SIGNAGE. REFER TO DETAILS ON SHEET A2/A2.1 FOR LIGHTED ID/LOGO SIGNS COORDINATE TIMING OF WORK WITH WALMART AND CONTRACTOR TO "Walmart" and "spark" SIGNAGE. EXISTING SIGNS FROM WAL-MART SIGNAGE MAY BE REUSED.
  - NOT USED.
  - INSTALL ALL DOORS, FRAME, AND TRIM BOARD CEILING IF REQUIRED BY FIELD CONDITIONS. EXISTING TENANT SIGNAGE TO BE REMOVED BY CONTRACTOR. PROVIDE SIGNAGE PER DETAILS ON SHEET A2/A2.1
  - REMOVE ALL SIGNS UNLESS NOTED OTHERWISE.
  - FURNISH AND INSTALL CONDUIT FOR LIGHTED SIGNAGE.
  - MAKE REQUIRED EXTERIOR WALL PENETRATIONS, INSTALL CONDUIT, AND SEAL PENETRATIONS PER SPECIFICATION SECTION 07900.
  - INSTALL SIGNAGE PER DETAILS ON SHEET A2/A2.1

SGA Design Group, Inc.  
1437 South Boulder, Suite 600  
Tulsa, Oklahoma 74119-3609  
T: 918.587.8901  
F: 918.587.8901  
www.sgaesigngroup.com

STIPULATION FOR REUSE  
THE REUSE OF EXISTING SIGNAGE IS AT THE USER'S RISK. THE USER SHALL BE RESPONSIBLE FOR VERIFYING THE CONDITION AND INTEGRITY OF EXISTING SIGNAGE PRIOR TO REUSE. THE USER SHALL BE RESPONSIBLE FOR OBTAINING ALL NECESSARY PERMITS AND APPROVALS FOR REUSE OF EXISTING SIGNAGE. THE USER SHALL BE RESPONSIBLE FOR OBTAINING ALL NECESSARY PERMITS AND APPROVALS FOR REUSE OF EXISTING SIGNAGE.

CONSULTANTS  
Walmart  
CAMDEN, SC  
STORE NO: 0634-226  
JOB NUMBER: 192011 - PHOTO - 172 PHOTO 5C

2020 GENERAL REMODEL  
ISSUE BLOCK

CHECKED BY: AVTRO  
DRAWN BY: MR  
PROTO CYCLE: 10/25/19  
DOCUMENT DATE: 12/19/19

THE REVISIONS TO THIS DRAWING IS TO BE MADE AT THE OPTION OF SGA DESIGN GROUP, INC. THIS DRAWING IS NOT TO BE USED FOR THE PURPOSE OF ANY OTHER PROJECTS WITHOUT THE WRITTEN CONSENT OF SGA DESIGN GROUP, INC. THIS DRAWING SHALL NOT BE CONSIDERED FINAL OR COMPLETE UNTIL IT IS SIGNED AND SEALED BY THE ARCHITECT.

NOTE: ALL SIGN PENETRATIONS ABOVE ROOF LEVEL MUST BE A CLEAR MINIMUM OF 8" ABOVE DECK

ELECTRICAL PENETRATIONS (TYP) FIELD VERIFY EXACT LOCATIONS  
SIGN MOUNTING LOCATION (TYP) FIELD VERIFY EXACT LOCATIONS  
ALTERNATE SIGN MOUNTING LOCATION (TYP) FIELD VERIFY EXACT LOCATIONS  
REF BLDG ELEVATIONS  
RD SIGN

EXTERIOR DETAILS

SHEET: A2.1

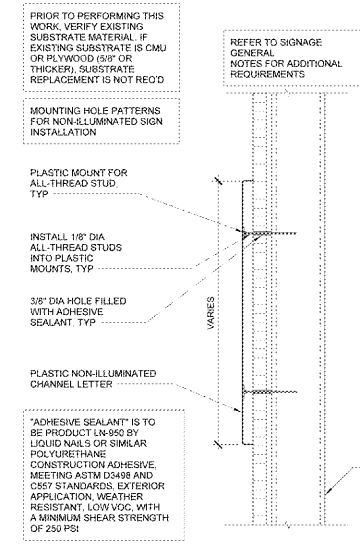

12 SIGN ATTACHMENT AT EIFS AND METAL STUD WALL  
1 1/2" x 1-0"

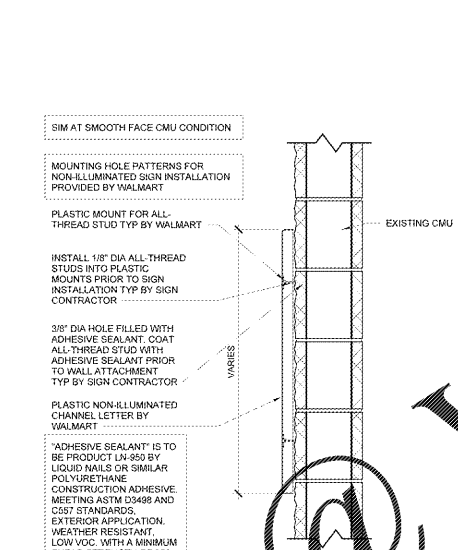

11 SIGN ATTACHMENT AT CMU WALL  
1 1/2" x 1-0"

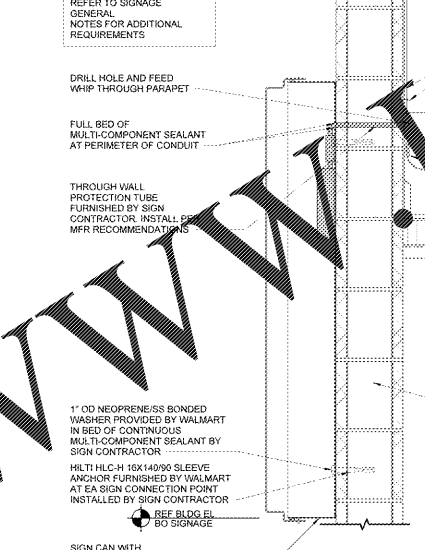

10 SIGN ATTACHMENT AT CMU WALL ABOVE ROOF LINE  
1 1/2" x 1-0"

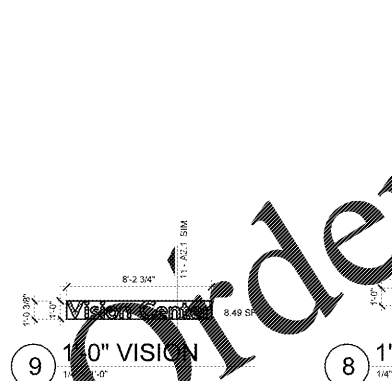

9 1'-0" VISION  
14\"/>

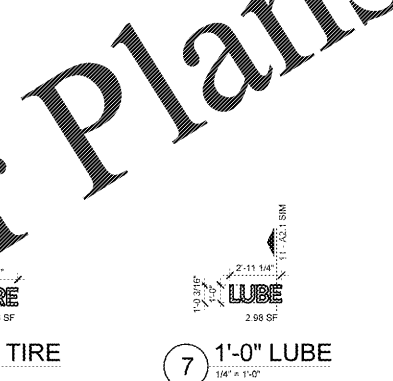

8 1'-0" TIRE  
14\"/>



7 1'-0" LUBE  
14\"/>

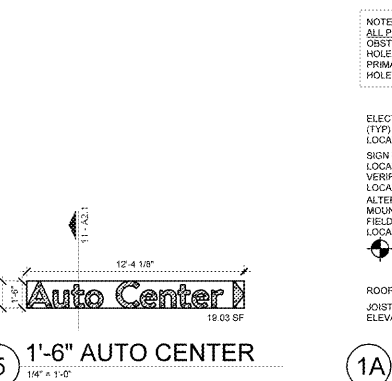

6 1'-6" AUTO CENTER  
14\"/>

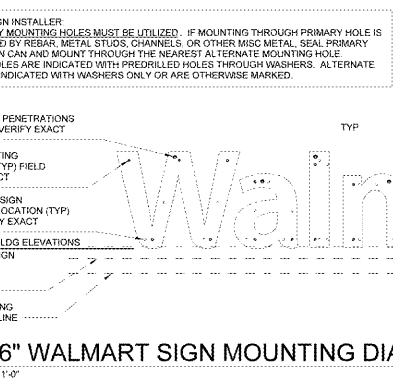

5 1'-6" AUTO CENTER  
14\"/>

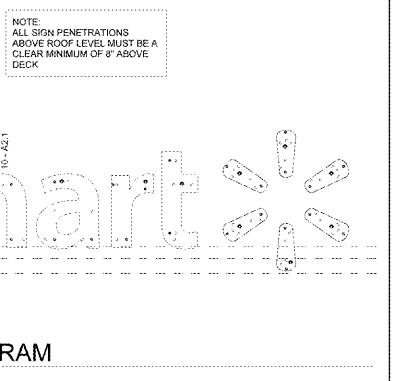

1A 5'-6" WALMART SIGN MOUNTING DIAGRAM  
14\"/>



4 2'-0" LAWN & GARDEN  
14\"/>

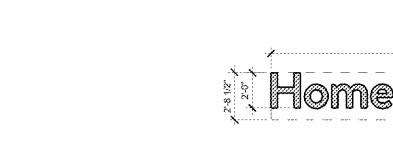

3 2'-0" HOME & PHARMACY  
14\"/>

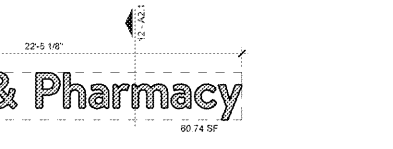

2 2'-0" GROCERY  
14\"/>

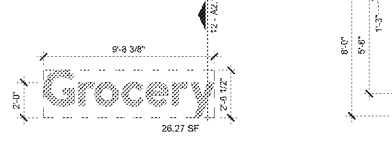

1 5'-6" WALMART SIGN  
14\"/>

Order Plans @ WWW.LDLINE.COM