

MINIMUM CONCRETE BLOCKING (C.Y.)\*

NOM. PIPE DIA. IN.	TEES & DEAD ENDS	90° BEND	45° BEND	22 1/2° BEND	11 1/4° BEND
4	1/3	1/3	1/3	1/3	1/3
6	1/3	1/3	1/3	1/3	1/3
8	1/3	1/2	1/3	1/3	1/3
10	2/3	3/4	1/2	1/3	1/3
12	3/4	1.0	2/3	1/3	1/3
14	1.0	1 1/2	3/4	1/2	1/3
16	1 1/3	2.0	1.0	1/2	1/3
18	1 2/3	2 1/3	1 1/3	2/3	1/3
20	2.0	3.0	1 2/3	3/4	1/2
24	3.0	4 1/3	2 1/3	1 1/3	2/3

\*CONCRETE SHALL BE 3000 P.S.I. MIX.

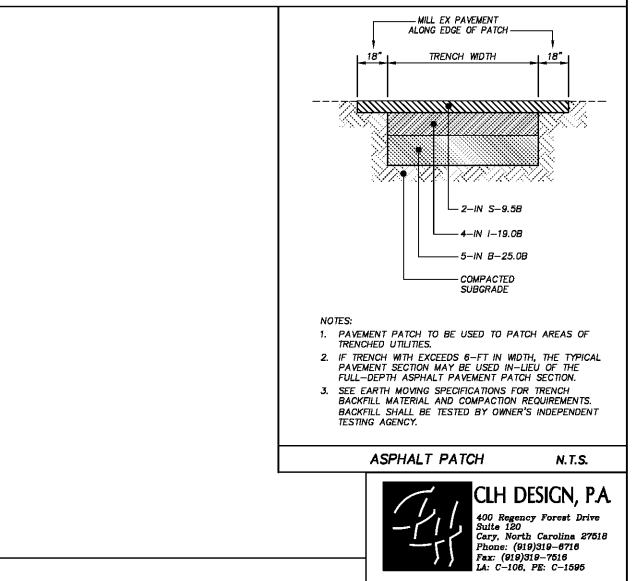
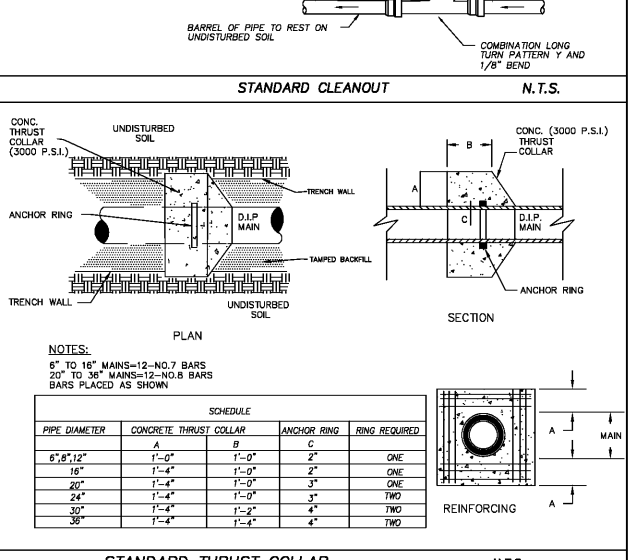

Order Plans @

**adwarchitects**  
environments for life  
architecture planning interiors  
2815 COLISEUM CENTRE DRIVE  
SUITE 500  
CHARLOTTE, NORTH CAROLINA 28217  
P704.379.1919  
F704.379.1920  
www.adwarchitects.com

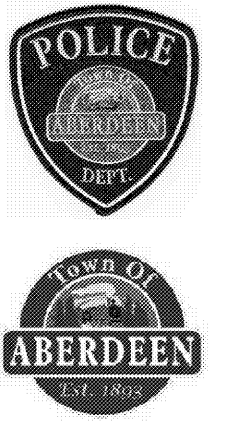

RENOVATION AND ADDITION  
**ABERDEEN POLICE DEPARTMENT**  
ABERDEEN, NORTH CAROLINA

SITE DETAILS  
DATE: 12.20.2019  
PROJECT NO: 18062  
REVISIONS  
NO. DATE DESCRIPTION  
1 12-20-2019 COORDINATION

THIS DRAWING IS THE PROPERTY OF ADW ARCHITECTS, P.A. AND SHALL NOT BE REPRODUCED OR COPIED IN WHOLE OR PART. IT SHALL NOT BE USED ON ANY OTHER PROJECT OR GIVEN TO ANY OTHER COMPANY OR AGENCY WITHOUT THE CONSENT OF ADW ARCHITECTS, P.A.

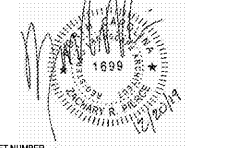

CLH DESIGN, P.A.  
400 Regency Forest Drive  
Suite 100  
Cary, North Carolina 27518  
Phone: (919)519-8716  
Fax: (919)519-7016  
LA: C-106, PE: C-1595  
**C706**