

305 N. Chippewa Street
Lumberton, NC 28358
Office: (910) 671-9530
Fax: (910) 618-0838
Email:
andersonengineeringpa@gmail.com
License #: C-0793

BUILDING PLANS FOR
COPART

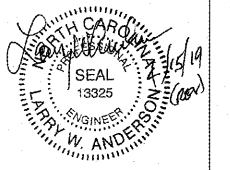

The creation of authorship contained in this drawing including but not limited to all design, text, specifications and images, are owned, except as otherwise expressly stated, by Anderson Engineering & Associates, P.A. and are protected by copyright and other intellectual property laws. This drawing may not be copied, reproduced, transmitted, displayed, distributed, sub-licensed, altered, stored for other projects or otherwise used in any manner without the prior written consent of Anderson Engineering & Associates, P.A., except to the extent that such use constitutes "fair use" under the Copyright Act of 1976 (17 U.S.C. §107), as amended. Project owner may keep one unaltered permanent copy to be used for intended project use only.

CASEWORK ELEV. / DETAILS

PERMIT SET

NO.	DATE	REASON
1	1-18-2019	ISSUE DATE
2	2-12-2019	OWNER REVIEW
3	4-10-2019	REDUCE BUILDING SIZE SCOPE: CRITICAL ROOMS CONTRACT DOCS DESK NOTES

SCALE: AS SHOWN
DRAWN BY: DJ
CHECKED BY: LWA
PROJECT NO.: 60-1656
DRAWING FILE: 1656
FILE NO.: 1656-BLDG-REV1
SHEET NO.

B106

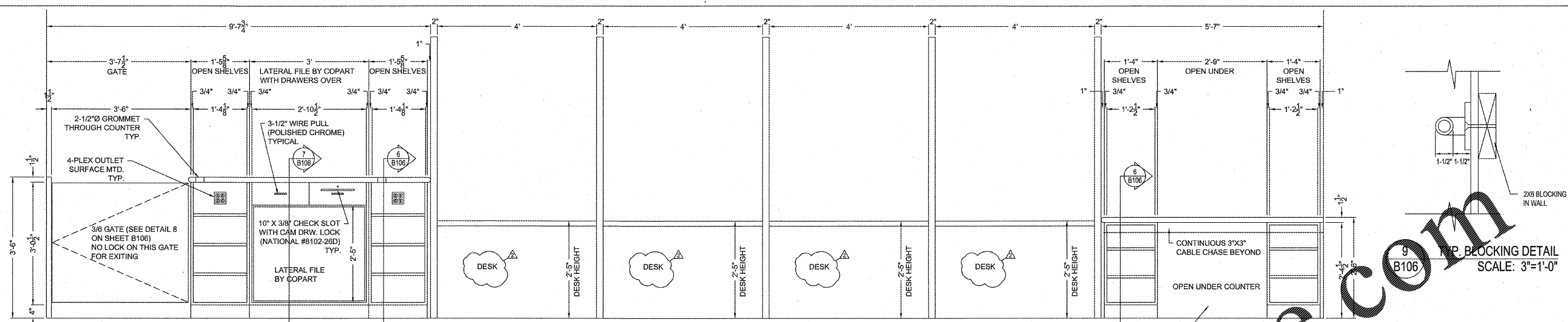

1 LOBBY #102 CABINERY & COUNTER INTERIOR ELEVATIONS
SCALE: 3/4"=1'-0"

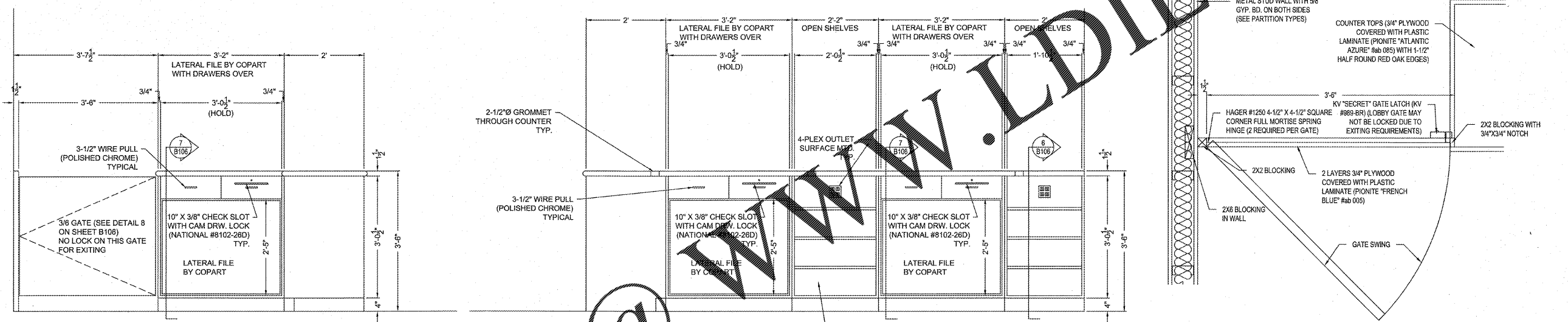

2 DISPATCH LOBBY #105 CABINERY & COUNTER INTERIOR ELEVATIONS
SCALE: 3/4"=1'-0"

3 DISPATCH LOBBY #105 CABINERY & COUNTER INTERIOR ELEVATIONS
SCALE: 3/4"=1'-0"

8 GATE DETAIL
SCALE: 1-1/2"=1'-0"

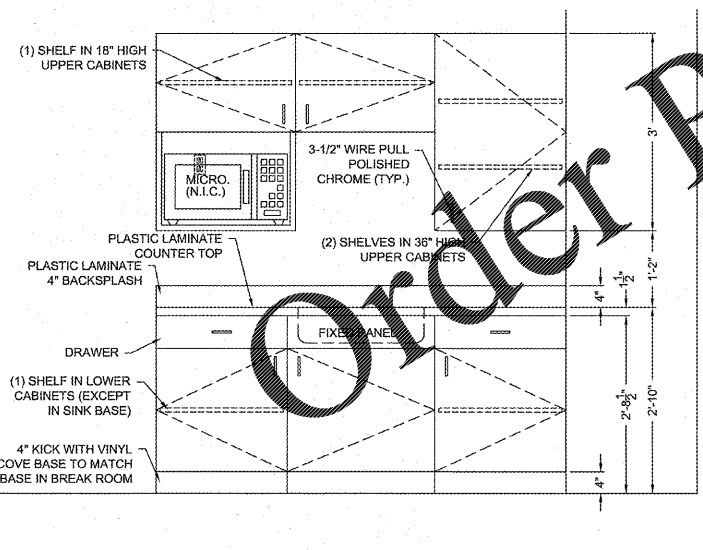

4 BREAK ROOM #109 ELEVATION
SCALE: 3/4"=1'-0"

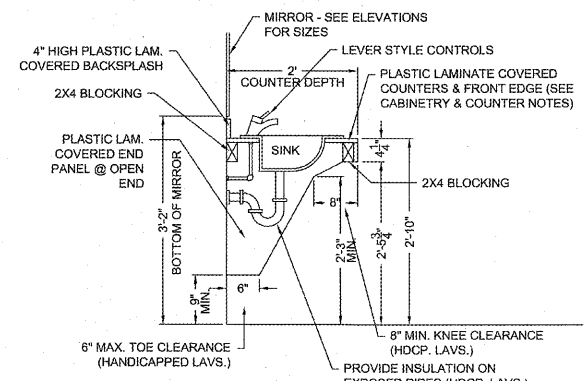

5 HDCP ACCESSIBLE COUNTER DETAIL
SCALE: 3/4"=1'-0"

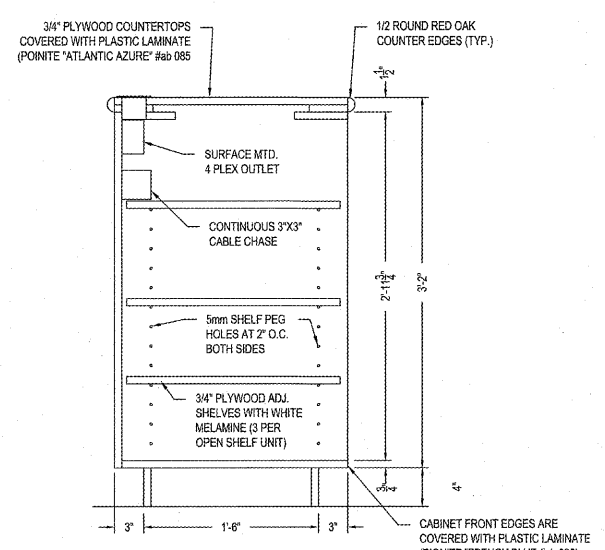

6 OPEN SHELVING DETAIL
SCALE: 1-1/2"=1'-0"

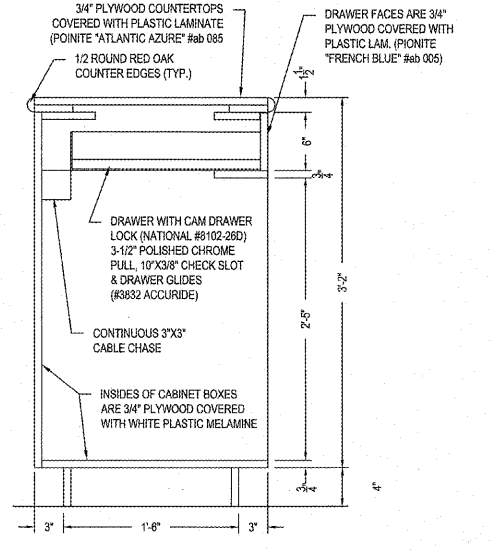

7 DRAWER / LATERAL FILE DETAIL
SCALE: 1-1/2"=1'-0"

Order Plans @

WWW.LDOnline.com

DETAILS AT OPEN HDCP ACCESSIBLE COUNTER IS SIMILAR TO CABINERY DETAILS, EXCEPT WIDTH IS 30" (VS. 24") AND THE CENTER PORTION IS OPEN UNDER FROM THE OPEN OFFICE AREA SIDE (LOBBY SIDE HAS A FRONT PANEL WITH A 3" DEEP X 4" HIGH KICK (SAME AS SHOWN IN DETAILS 6 & 7 ON DWG. B106)

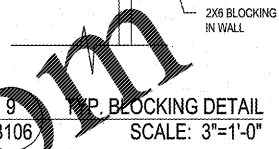

9 BLOCKING DETAIL
SCALE: 3"=1'-0"