

- INSTALL TEST FIXTURE IN EQUALIZATION LINE AS SHOWN ABOVE MULTI-PRODUCT DISPENSER
- RUN THE SUBMERSIBLES WITH DISPENSER NOZZLES CLOSED AND VALVE "A" CLOSED. VALVE "B" OPEN. THE NORMAL VACUUM READING SHOULD BE 15-20". NOTE: HIGHER RVP FUELS AND/OR HIGHER FUEL TEMPERATURES CAN RESULT IN LOWER VACUUM READINGS. IF THE VACUUM IS SOMEWHAT LESS THAN 15" THERE IS THE POSSIBILITY OF BLOCKAGE IN THE SIPHON PASSAGES (PLUGGED SIPHON NOZZLE AND/OR VENTURI PLUGGED SIPHON PORT, PLUGGED/PINCHED RETURN TUBE). TO REMEDY, CLEAN THE PASSAGES AND REPLACE IF NECESSARY. IF THE PASSAGES ARE CLEAN AND THE VACUUM READING IS ZERO OR VERY LOW A LEAK MAY BE PRESENT IN THE FLOW PATH TO THE SIPHON JET OR IN THE DISCHARGE TUBE. PULL THE EXTRACTABLE PORTION AND REPAIR AS NECESSARY
- RUN THE SUBMERSIBLE WITH DISPENSER NOZZLES CLOSED AND VALVE "A" CLOSED. VALVE "B" OPEN. WHEN THE VACUUM READING REACHES 15-20" SHUT THE PUMP OFF AND WAIT TWO MINUTES. IF THE READING DROPS TO ZERO, THE SIPHON CHECK VALVE IS NOT HOLDING. REMOVE AND CLEAN OR REPLACE. NOTE: SIPHON CHECK VALVES MAY HOLD AT HIGH VACUUMS, BUT LEAK UNDER LOW VACUUMS. TEST THE SIPHON CHECK VALVE AT A LOWER VACUUM BY BLEEDING THE VACUUM TO ABOUT 5" HG AND REPEAT THE TEST
- RUN THE SUBMERSIBLE WITH BOTH VALVES "A" AND "B" OPEN AND THE DISPENSER NOZZLES CLOSED FOR APPROXIMATELY 5-10 MINUTES. CLOSE VALVE "B" AND THEN SHUT OFF PUMP. IF VACUUM DROPS, THERE IS A LEAK IN THE EQUALIZATION LINE BETWEEN THE TANKS ABOVE THE LEVEL OF THE PRODUCT. REPAIR LEAKS AND REPEAT STEP 4
- WRITTEN VERIFICATION OF THE TESTING FOR EQUALIZATION SHALL BE SIGNED BY THE GENERAL CONTRACTOR AND TANK INSTALLER. VERIFICATION SHALL BE PROVIDED TO OWNER AS PART OF THE CLOSE OUT DOCUMENTS

10 EQUALIZATION SYSTEM TESTING  
NTS

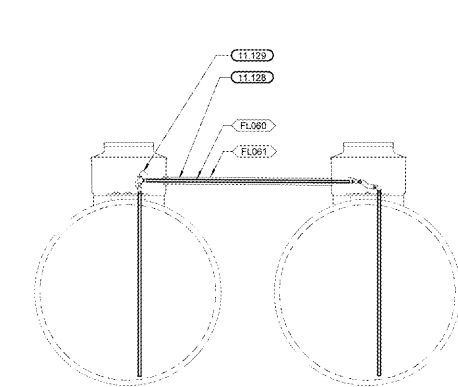

9 EQUALIZATION PIPING SECTION  
NTS

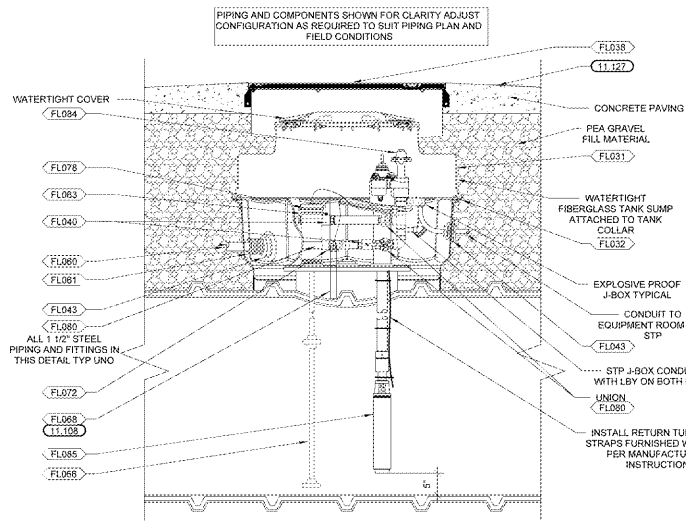

8 DIESEL STP SUMP SECTION  
NTS

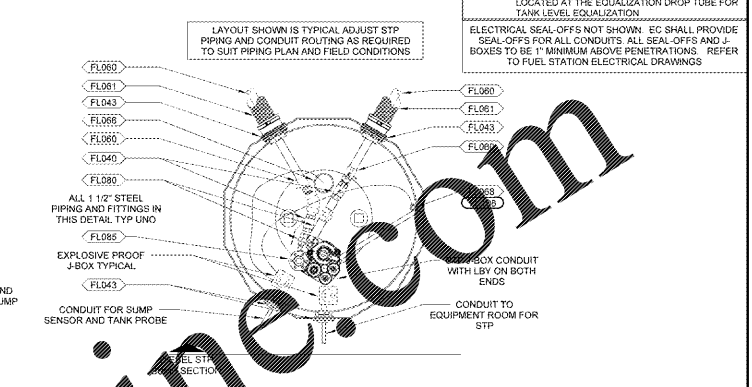

7 DIESEL STP SUMP PLAN  
NTS

KEYNOTES	
11.106	SUMP SENSOR TO REST ON THE LOWEST POINT OF SUMP ENCLOSURE. SECURE SENSOR USING MANUFACTURER'S UNIVERSAL MOUNTING KIT.
11.127	SET RIM OF MANHOLE 1" ABOVE SURROUNDING GRADE. SLOPE CONCRETE AWAY FROM MANHOLE AT MAXIMUM 1/4" PER FOOT.
11.128	1 1/2" FLEXIBLE DOUBLE WALL EQUALIZATION PIPING. SLOPE MINIMUM 1/8" PER FOOT DOWN FROM TANK TO TANK. REFER TO EQUALIZATION PIPING SECTION.
11.129	1/4" SOFT TUBING FROM SIPHON CHECK VALVE TO EQUALIZATION TEST VALVES AND GAUGE TO EQUALIZATION PIPING TEE. REFER TO EQUALIZATION PIPING SECTION AND SYSTEM TEST DETAIL.
11.130	1 1/2" X 1 1/2" X 1 1/2" SCH 40 BLACK IRON TEE. LOCATED AT THE EQUALIZATION DROP TUBE FOR TANK LEVEL EQUALIZATION.

ELECTRICAL SEAL-OFFS NOT SHOWN. EC SHALL PROVIDE SEAL-OFFS FOR ALL CONDUITS. ALL SEAL-OFFS AND J-BOXES TO BE 3" MINIMUM ABOVE PENETRATIONS. REFER TO FUEL STATION ELECTRICAL DRAWINGS.

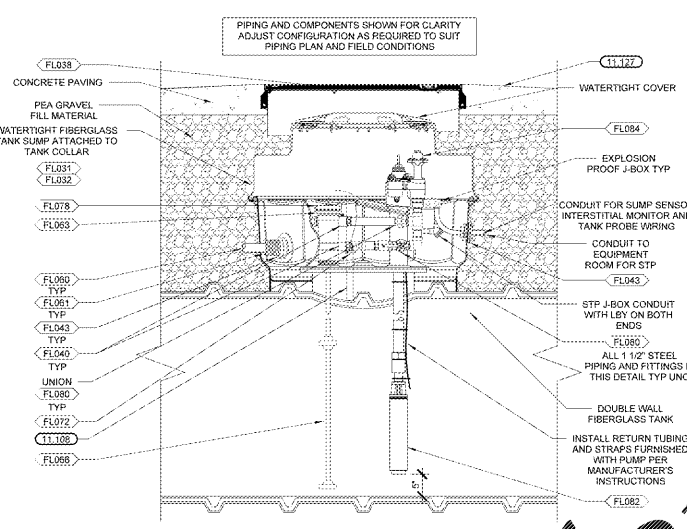

6 SUPER UNLEADED STP SUMP SECTION  
NTS

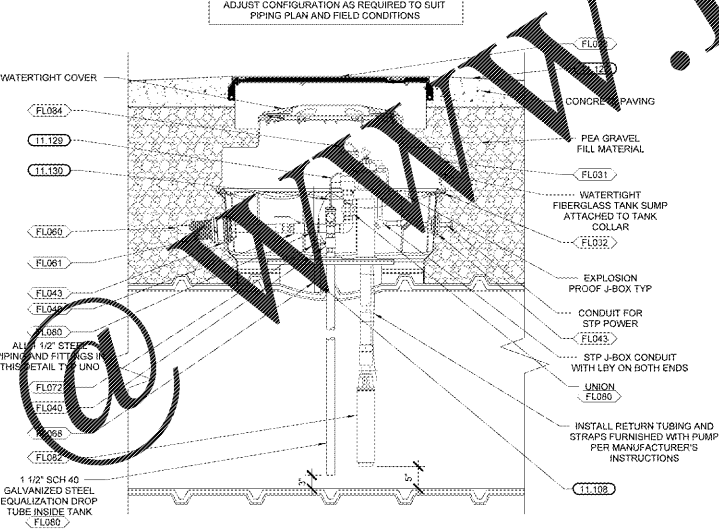

5 UNLEADED STP SUMP SECTION TANK #2  
NTS

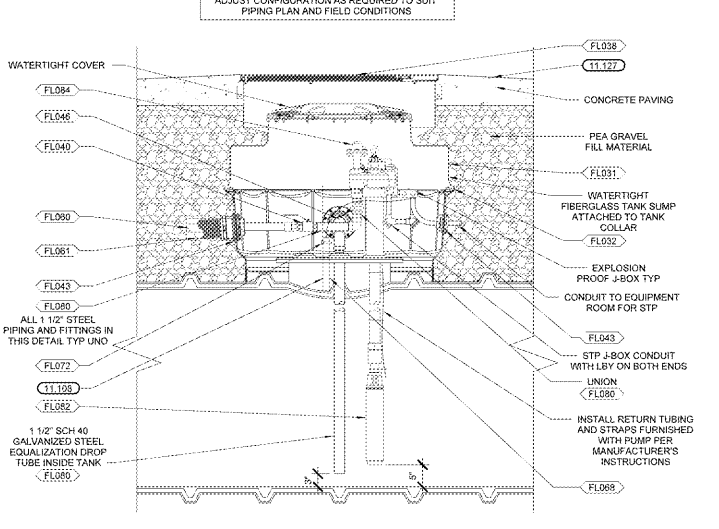

4 UNLEADED STP SUMP SECTION TANK #1  
NTS

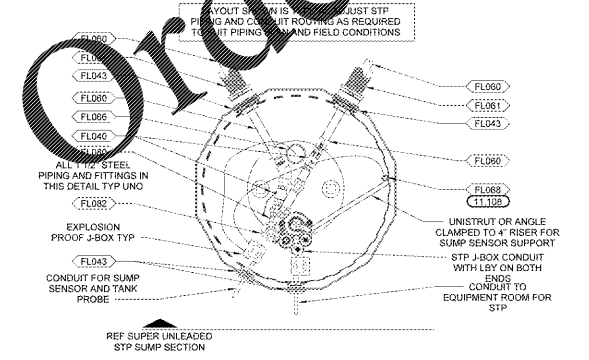

3 SUPER UNLEADED STP SUMP PLAN  
NTS

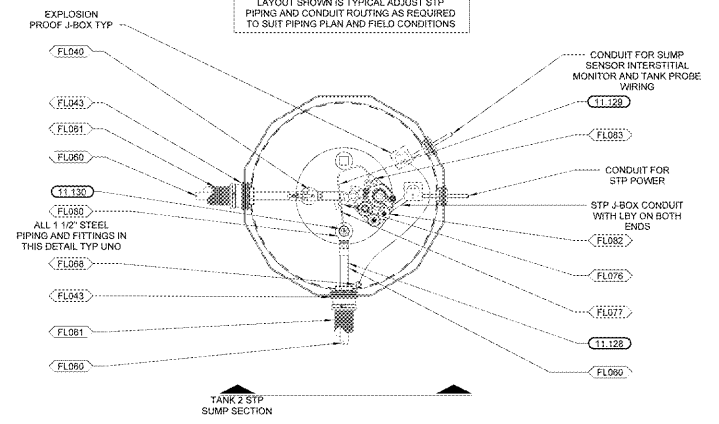

2 UNLEADED STP SUMP PLAN TANK #2  
NTS

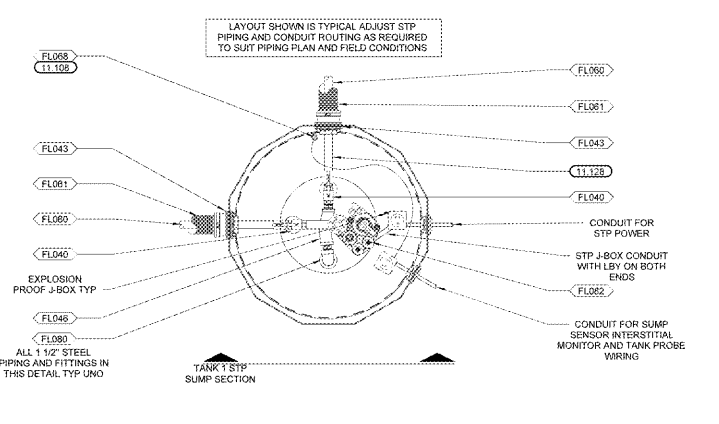

1 UNLEADED STP SUMP PLAN TANK #1  
NTS

STIPULATION FOR REVISIONS:  
REVISIONS SHALL BE MADE BY THE GENERAL CONTRACTOR AND SHALL BE SIGNED AND DATED BY THE GENERAL CONTRACTOR AND THE PROJECT ENGINEER.  
NO REVISIONS SHALL BE MADE TO THIS DRAWING WITHOUT THE WRITTEN APPROVAL OF THE PROJECT ENGINEER.

CONTRACTOR'S:  
David P. Kimball  
PROJECT ENGINEER  
DATE: 03/20/19  
DRAWN BY: DAD  
FILE NAME: FST3  
PROTO CYCLE: 102516  
DOCUMENT DATE: 08/08/19

ANDERSON, SC  
CLUB#: 6463  
3407T PHOTO  
SMAHS-102

ISSUE BLOCK

CHECKED BY: JMS  
DRAWN BY: DAD  
FILE NAME: FST3  
PROTO CYCLE: 102516  
DOCUMENT DATE: 08/08/19

NOT FOR CONSTRUCTION

TANK SUMP DETAILS

SHEET  
FST3