

**FINISH SYMBOLS**

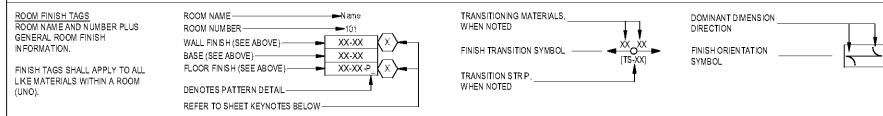

**CEILING SYMBOL LEGEND**

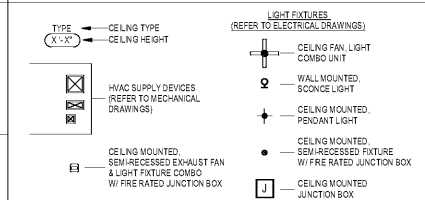

**UNIT A1 DOOR SCHEDULE**

**SCHEDULE KEY:**

TYPE	DOOR TYPE	DOOR MATERIAL	FRAME TYPE	FRAME MATERIAL	DOOR / FRAME FINISH	DETAIL	FIRE RATING	HARDWARE SET
AS SPECIFIED ON FLOOR PLANS	REFER TO LEGEND ON A-601	WD WOOD	PH PRE-HUNG	WD WOOD	PF PRE-FINISHED PTD PAINTED	REFER TO DETAILS AS INDICATED	N MINUTES	REFER TO PROJECT MANUAL DIVISION 08 FOR HARDWARE SCHEDULE

**SCHEDULE NOTES:**  
1. REFER TO A-1001 & A-601 FOR UNIT ENTRY DOOR INFORMATION.  
2. ALL DOOR OPENINGS TO BE 4" FROM F.O. WALL UNLESS OTHERWISE NOTED.

UNIT	TYPE	SIZE	PAIR	DOOR	FRAME	DETAIL	FIRE RATING	NOTES	
W	H	W	H	TYPE	MATL	FINISH	WALL	LBL	
A3	2'-0"	7'-0"	13'-6"	PH	WD	PTD	PH	WD	PTD
A4	2'-10"	7'-0"	13'-6"	PH	WD	PTD	PH	WD	PTD
A5	2'-10"	7'-0"	13'-6"	PH	WD	PTD	PH	WD	PTD
A7	3'-0"	7'-0"	13'-6"	PH	WD	PTD	PH	WD	PTD

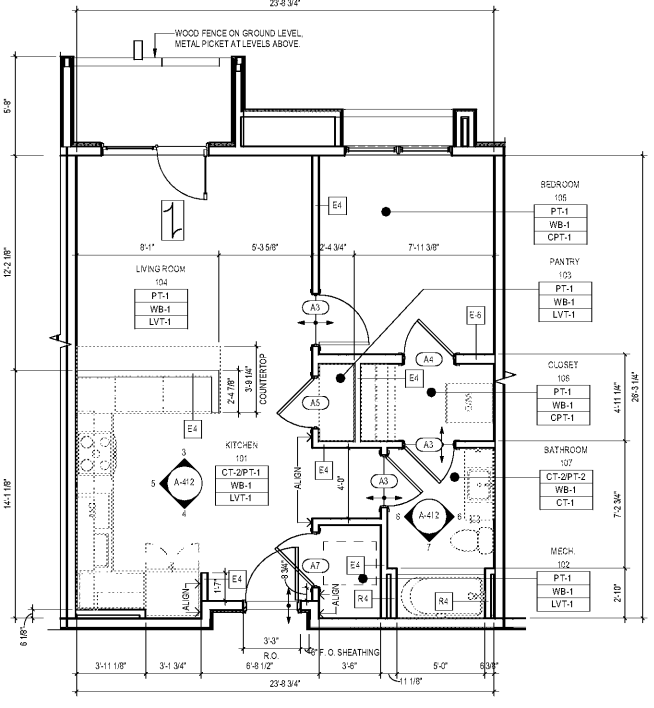
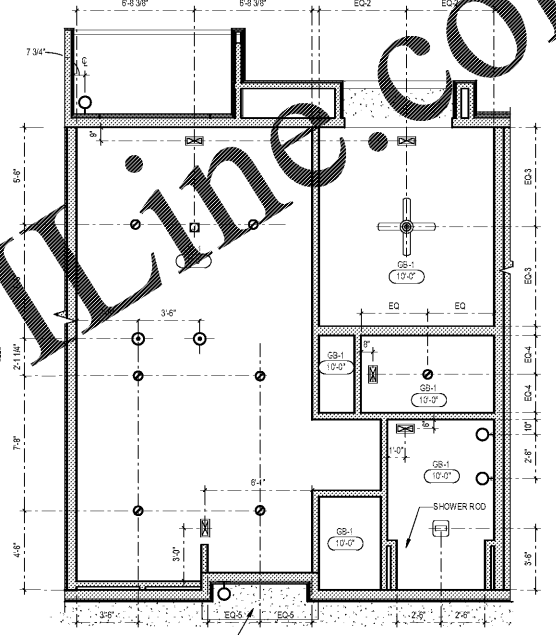
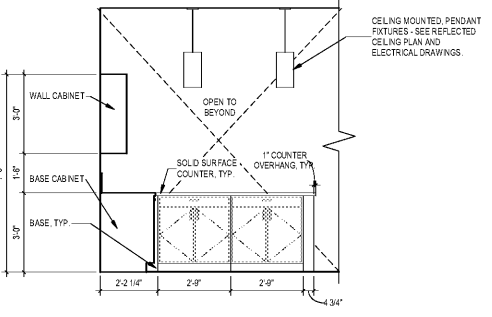
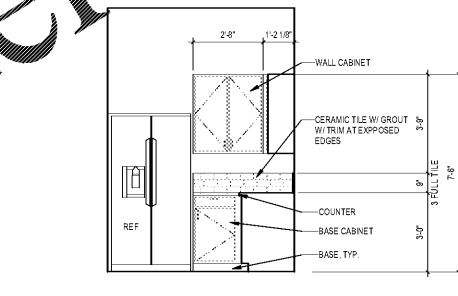
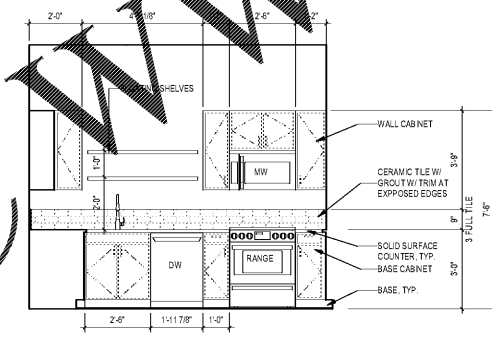
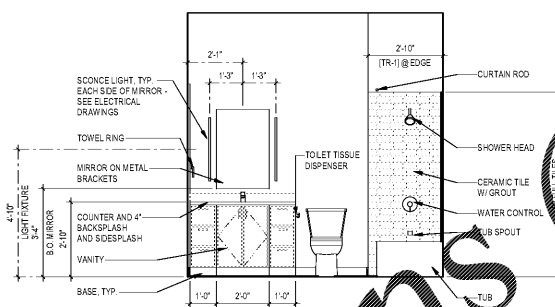
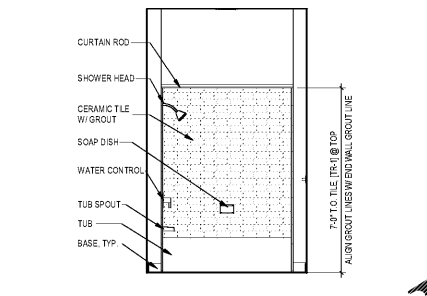
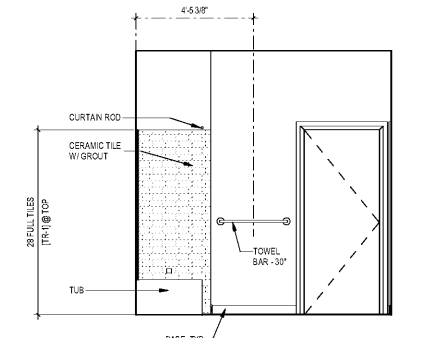

WWW.LDILine.com

Order Plans @

1925 Prospect Ave.  
Orlando, FL 32814  
P (407) 661-9100  
F (407) 661-9101  
www.rp.com

**Culacci & Peterson**  
Architects Engineers Planners

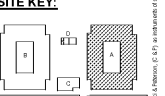
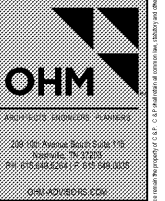

CLIENT NAME  
**HUTTON DEVELOPMENT**  
756 Cherry Street  
Chattanooga, TN 37402

PROJECT NAME  
**ROCKLEDGE FLATS - BUILDING A**  
220 Barton Boulevard  
Rockledge, FL 32955

SHEET TITLE  
**UNIT PLANS & ELEVATIONS - A1 - ONE BEDROOM**

Revision Schedule	
No.	Description

PROJECT NO. 210002	DATE 11/15/2019
DRAWN N/A	CHECKED N/A

A-412

GMP PRICING SET 15 NOVEMBER 2019