

GENERAL DETAIL NOTES

- SUSPEND UNIT HEATERS FROM UNISTRUT CHANNELS MOUNTED TO ROOF TRUSS WITH VIBRATION ISOLATORS EQUIPPED HANGER RODS OR AN APPROVED EQUAL METHOD.
- ALL EQUIPMENT FURNISHED BY CONTRACTOR SHALL HAVE MAGNETIC STARTERS OF SIZE AND CAPACITIES AS REQ'D. FOR PROPER EQUIPMENT OPERATION. FURNISH WEATHERPROOF BOXES (NEMA 3R) FOR EXTERIOR USE.
- EXTEND ALL METALBESTOS FLUES OF DIAMETERS SHOWN THROUGH ROOF TO HEIGHT REQUIRED BY CODE WITH ALUMINUM ROUND TOP. PROVIDE VENTILATING THIMBLE THROUGH ROOF FOR CLEARANCE AROUND STACK AND SUPPORT SECURELY. PROVIDE WEATHER TIGHT RAIN COLLAR AND FLASHING AT PENETRATION.
- ALL THERMOSTATS TO BE FURNISHED BY HVAC CONTRACTOR TO ELECTRICAL CONTRACTOR FOR INSTALLATION.
- FURNISH AND INSTALL UL RATED FIRE DAMPERS W/FUSIBLE LINKS AND ACCESS PANELS IN DUCT WORK AT PENETRATIONS OF FIRE RATE ASSEMBLIES AS REQUIRED BY CODE.
- WIRING SCHEMATICS OF ALL HVAC EQUIPMENT SHALL BE FURNISHED BY HVAC CONTRACTOR TO ELECTRICAL CONTRACTOR.
- ADJUST ALL FANS TO PROPER RPM TO ASSURE CFM REQUIRED AND BALANCE ALL GRILLES AND DIFFUSERS TO CFM SHOWN ON DRAWINGS. (+5%)
- WHERE DRAWINGS AND SPECIFICATIONS EXCEED GOVERNING CODE REQUIREMENTS. DESIGN SHALL GOVERN. INSTALL NO WORK CONTRARY TO OR BELOW MINIMUM LEGAL STANDARDS. WHETHER DRAWINGS AND SPECIFICATIONS FULLY COMPLY OR NOT.
- ROUTE ALL PIPING TIGHT TO CEILING AND WALLS, PARALLEL AND PERPENDICULAR TO BUILDING STRUCTURE WHERE POSSIBLE.
- ALL SHUT OFF VALVES TO BE ACCESSIBLE TO ASSOCIATES WITHOUT THE USE OF A LADDER OR STEP-STOOL.

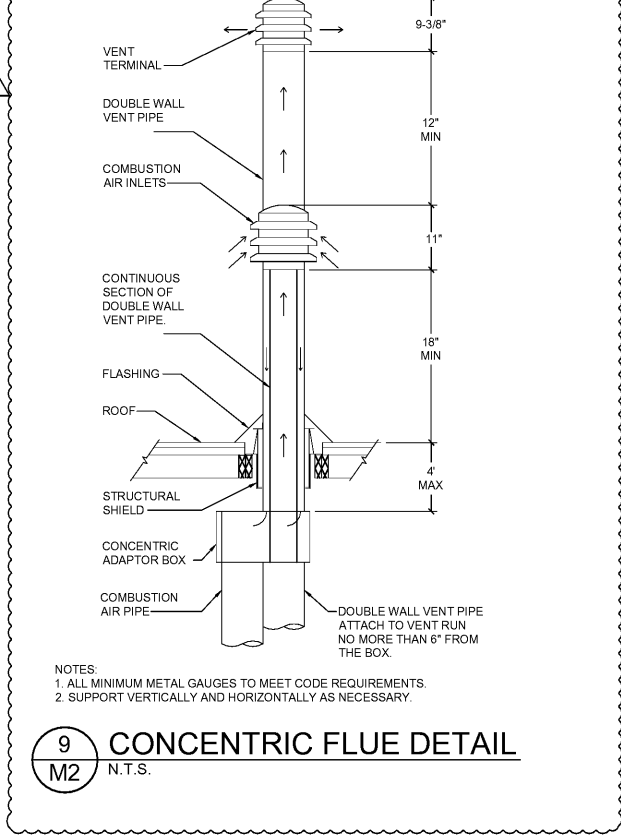
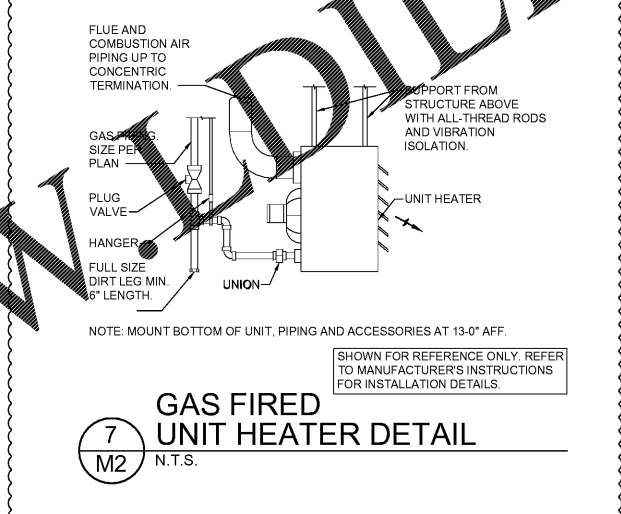
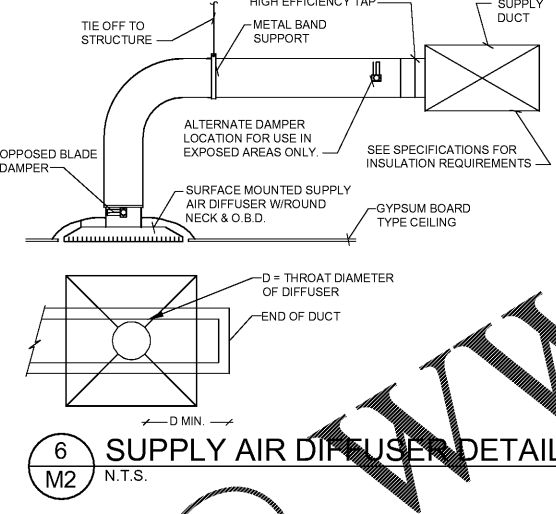
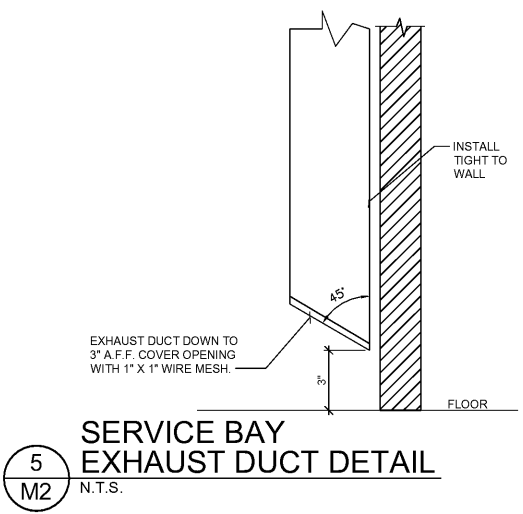

Order Plans @ [www.dilling.com](http://www.dilling.com)

**Firestone** COMPLETE AUTO CARE

THIS DRAWING IS THE PROPERTY OF BRIDGESTONE RETAIL OPERATIONS, LLC AND IS LOANED ON THE EXPRESS CONDITION THAT IT IS NOT TO BE REPRODUCED IN ANY MANNER OR TO BE USED FOR ANY PURPOSE OTHER THAN THAT SPECIFICALLY ADMITTED BY BRIDGESTONE RETAIL OPERATIONS, LLC. ADMISSION TO THE EXCLUSIVE OWNERSHIP AND TO THE DRAWING BY BRIDGESTONE RETAIL OPERATIONS, LLC.

NEW FCAC STORE  
 2019 - JANUARY - SMALL I  
 233 S AIRLINE HWY  
 GONZALES, LA

STATE OF LOUISIANA  
 BRIAN J. TIMMONS  
 License No. 33071  
 PROFESSIONAL ENGINEER  
 11/08/19

BID SET  
 11.18.19  
 TRCI

ISSUE BLOCK	
11/11/19	CB #1
PROPERTY NO.:	160013
6 DIGIT NO.:	902556
4 DIGIT NO.:	014W
AOR PROJECT NUMBER:	1955827
TO PERMIT DATE:	7-30-2019
TO BID DATE:	##-##-##
SHEET TITLE	
MECHANICAL DETAILS	
SHEET NUMBER	
<b>M2</b>	