

| REV NO. | DATE | REMARKS |
|---------|----------|------------------|
| 1 | 04/20/19 | DDDC PRELIMINARY |
| 2 | 08/01/19 | SITE PACKAGE |
| 3 | 08/16/19 | DDDC CHECK SET |

One Piedmont Center, Suite 303 3565 Piedmont Road Atlanta, Georgia 30305

Carter & Sloop
CONSULTING ENGINEERS
CANTON, MISSISSIPPI
ATHENS, GEORGIA
MACON, GEORGIA
1031 STONEBRIDGE PARKWAY, WATKINSVILLE, GA 30527, 706.728.4113 TEL. 706.747.4546 FAX
GA COA LICENSE # P0901904 EXPIRES 6/30/2020

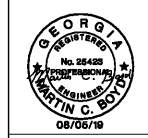

© COPYRIGHT 2019
BRUNNENBERG, REYNOLDS,
& ASSOCIATES, INC.
ALL RIGHTS RESERVED. NO PART
OF THIS DOCUMENT IS TO BE REPRODUCED
OR TRANSMITTED IN ANY FORM OR BY ANY
MEANS, WITHOUT THE WRITTEN
PERMISSION.

J.H. HOUSE ELEMENTARY SCHOOL
2971 NE HIGHWAY 20, Conyers, GA 30012

DATE
JOB NO: 218036.00
CAS PROJ. NO: S4800.002
SHEET NO.

ISSUED FOR CONSTRUCTION

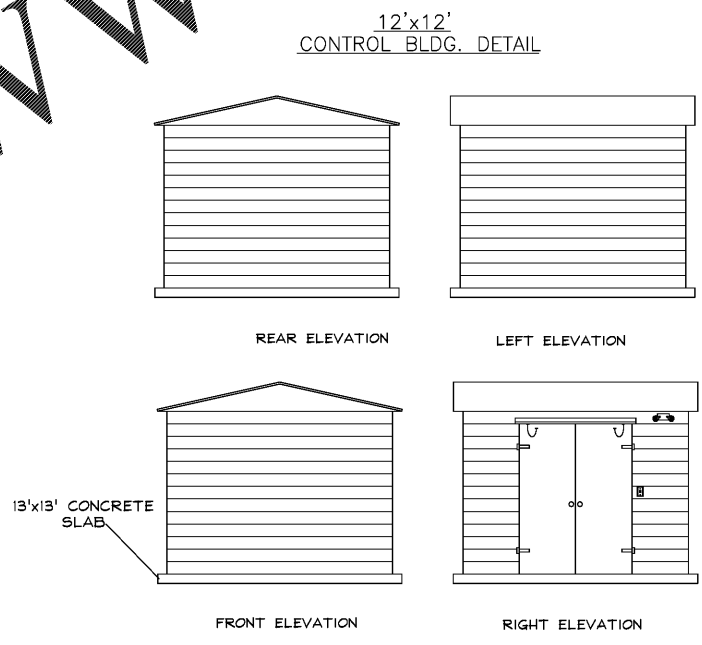
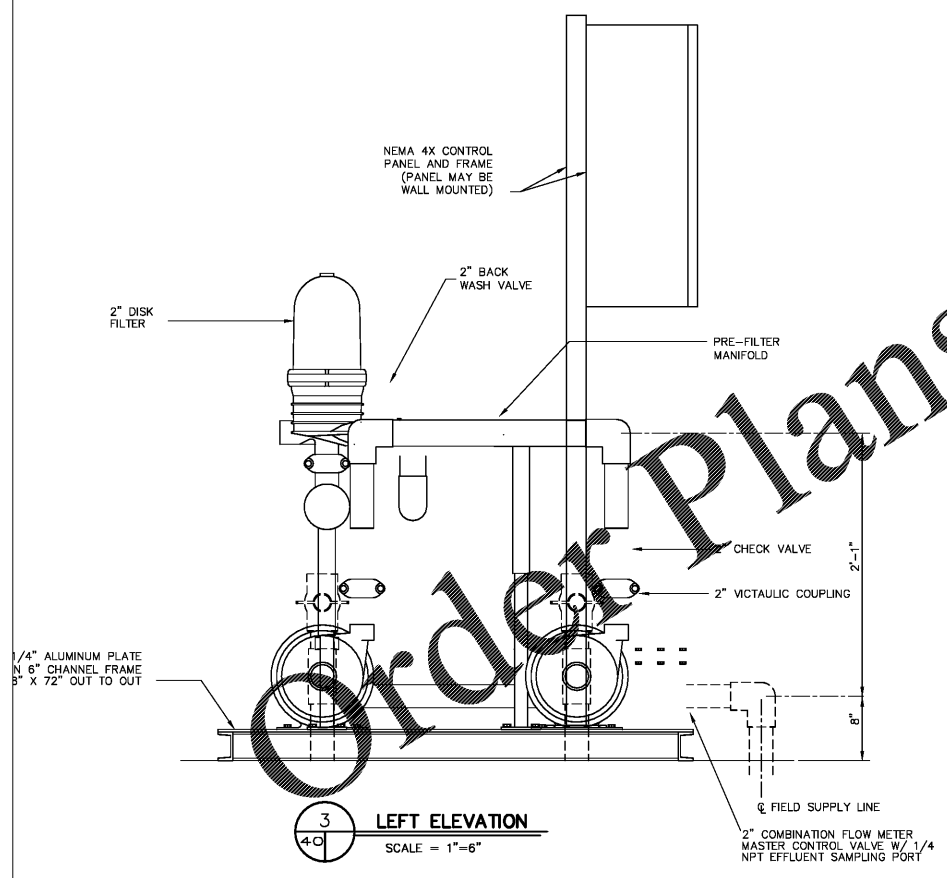
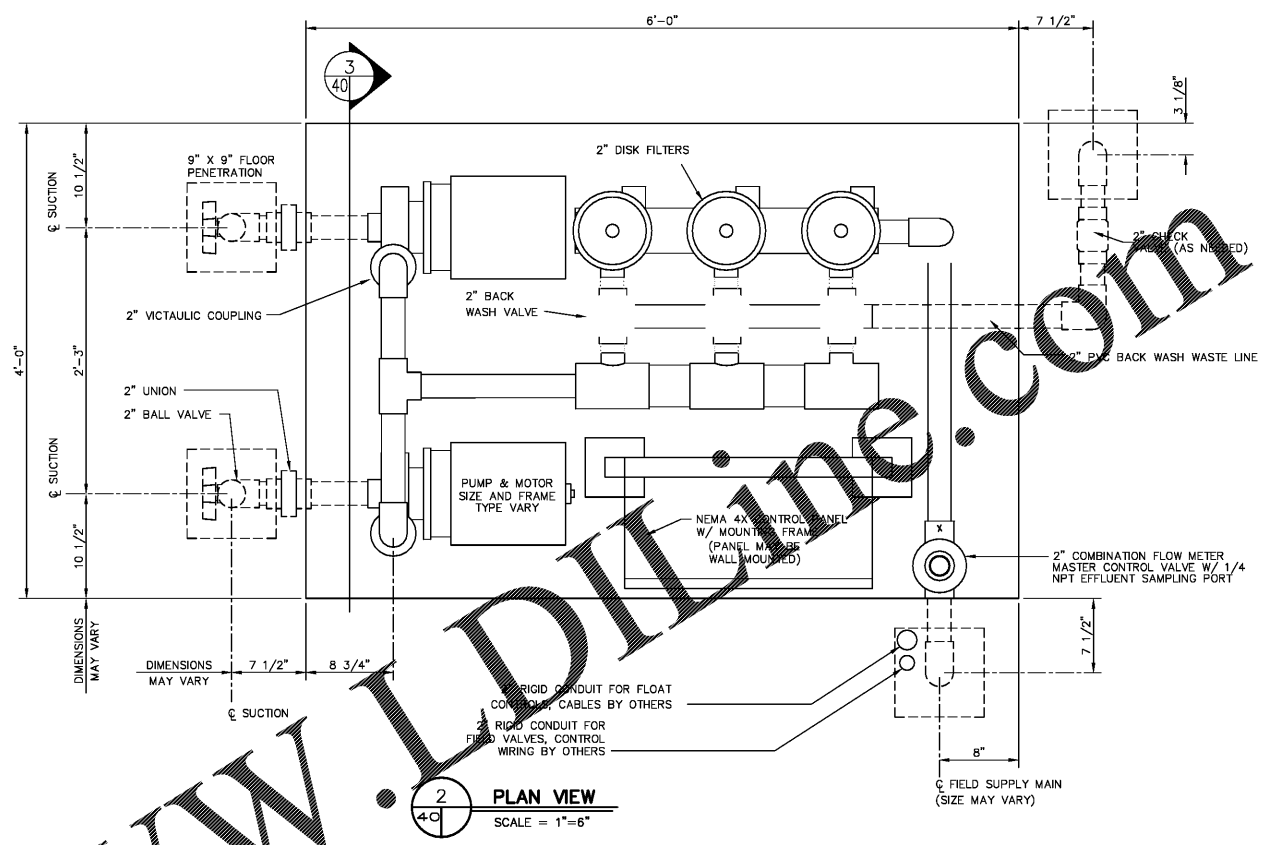
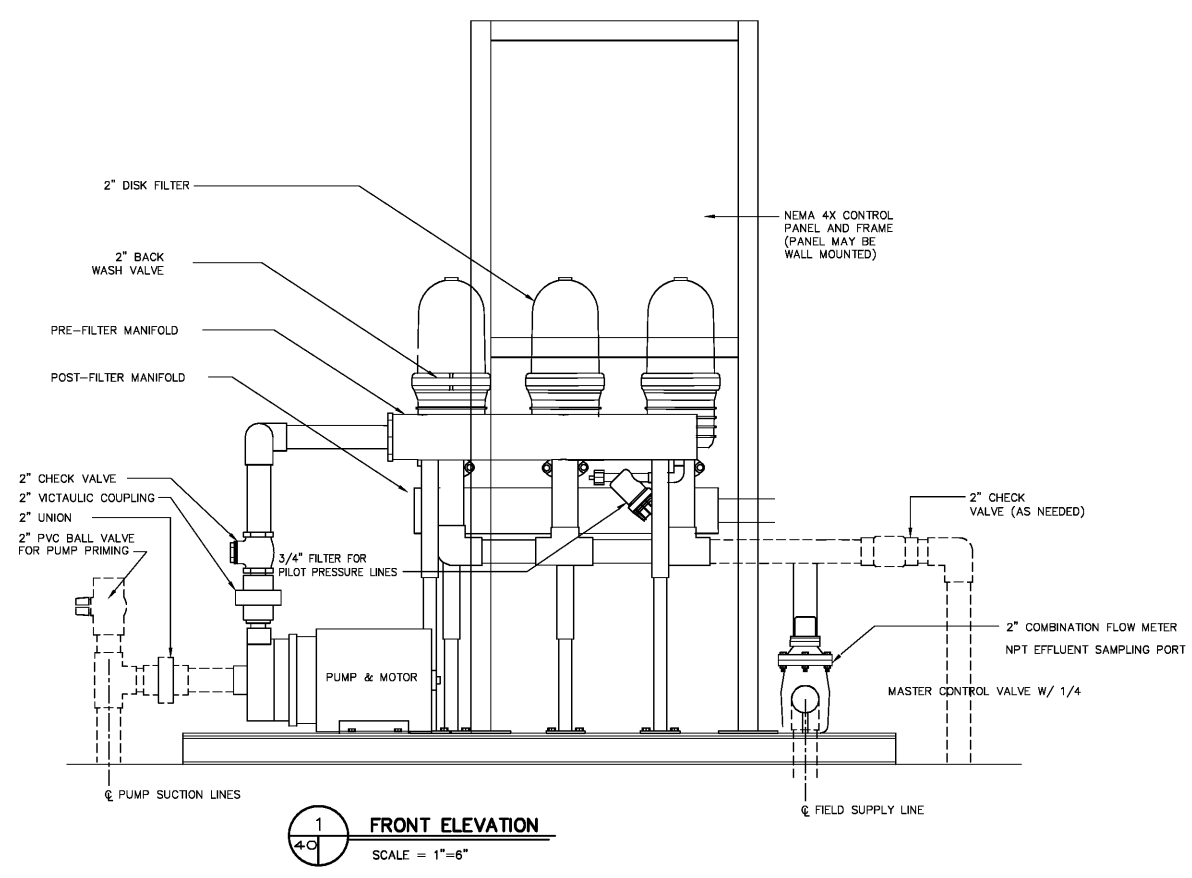

- Note:**
- The Control bldg. shall be built to local building codes.
 - The bldg. shall be interior lighted, insulated, heated and ventilated.
 - The bldg. shall have a double locking door entrance and an exterior light.

PERC-RITE® IS THE REGISTERED TRADEMARK OF WASTE WATER SYSTEMS, INC.

PUMP DETAILS

